

PHILIPS RESPIRONICS V60 SERVICE MANUAL



Quick Links

[Alarms and Messages](#)

[Annual Preventive Maintenance Instructions](#)

Table of Contents

[Table of Contents](#)

[Intended Use](#)

[Recommended Test Equipment, Tools, and Supplies](#)

[Where to Go for Help](#)

[General](#)

[Preparing for Ventilation](#)

[Operation](#)

[Alarms and Messages](#)

[Care and Maintenance](#)

[First-Time Installation](#)

[Communications Interface](#)

[Diagnostic Mode](#)

[Pneumatics](#)

[Air Inlet](#)

[Air Inlet Filter](#)

[Air Flow Sensor](#)

[Machine and Proximal Pressure Transducers](#)

[Barometric Pressure Transducer](#)

[Oxygen Pressure Transducer](#)

[Manifold, Oxygen Inlet Filter, Filter Element](#)

[Oxygen Solenoid Valve](#)

[Oxygen Flow Sensor](#)

[Blower](#)

[Solenoid Valves](#)

[Electronics](#)

[Power management \(PM\) PCBA](#)

[Power Supply](#)

[Internal Battery](#)

[CPU PCBA](#)

[Motor Controller \(MC\) PCBA](#)

[Data Acquisition \(DA\) PCBA](#)

[Flow Sensors](#)

[User Interface](#)

[LCD Assembly](#)

[Backlight Inverter PCBA](#)

Touch Screen Assembly

Nav-Ring Assembly (Rotary Adjustment)

Power Switch Overlay

Switch PCBA

UI PCBA

Electronic Signal Paths

Annual Preventive Maintenance Instructions

System Settings

Selecting a Language

Setting Date and Time

Restoring Default Settings

Selecting Pressure Units

Enabling Software Options

Baud Rate

Service

Viewing Ventilator Information

Pneumatic Controls

Output Controls

Miscellaneous

Touch Screen Calibration

Diagnostic Codes, Alarms, and Troubleshooting

Miscellaneous Troubleshooting Tips

Setting Up the Service PC

Setting Up the Serial Interface Using HyperTerminal

Setting Up the Serial Interface Using Tera Term

Generating a Diagnostic Report (DRPTA)

Clearing the Significant Event Log

Downloading Ventilator Software

Programming the Ventilator Serial Number and Power-On Hours

Programming the Ventilator Serial Number

Programming Ventilator Power-On Hours

Disconnecting Power

Air Inlet Filter

Internal Battery

Top Cover

AC Inlet

Fan

Oxygen Inlet

Motor Controller (MC) PCBA
Separating the UI from the Base
Front Panel
Gas Outlet Port
UI Retainer
Proximal Pressure Port
Speakers
Power Management (PM) PCBA
Power Supply
CPU PCBA
Real-Time Clock Battery
Left Side Wall
Gas Delivery Subsystem (GDS)
Right Side Wall
Oxygen Inlet Filter
Data Acquisition (DA) PCBA
Air and Oxygen Flow Sensor Assembly
Oxygen Solenoid Valve
Solenoid Valves
Blower
Opening the User Interface (UI)/ Rear Bezel
Power Switch Overlay
Switch PCBA
Nav-Ring Assembly
Front Bezel, Touch Screen
LCD
User Interface (UI) PCBA
Backlight Inverter PCBA
LCD Tray
Bottom Feet
Labels
Required Test Equipment
Preliminary Cleaning, Inspection and Setup
View and Record Ventilator Information
Pneumatic Calibration Analyzer Setup
Measurement Selection Screen
Averaging Setup Menu

Trigger Options

Configurations Menu

Performance Verification Procedures

Electrical Safety (Test 1)

Leak Tests (Test 2)

Controls (Test 3)

Pressure Accuracy (Test 4)

Air Delivery/Flow Accuracy (Test 5)

Oxygen Flow Accuracy (Test 6)

Oxygen Accuracy (Test 7)

S/T Performance (Test 8)

Alarms (Test 9)

Power Fail (Test 10)

Internal Battery (Test 11)

Returning Ventilator to Operation

Performance Verification Troubleshooting/Repair

Test 1: Electrical Safety

Test 2: Leak Tests

Test 3: Controls

Test 4: Pressure Accuracy

Test 5: Air Delivery/Flow Accuracy

Test 6: Oxygen Flow Accuracy

Test 7: Oxygen Accuracy

Test 8: S/T Performance

Test 9: Alarms

Test 10: Power Fail

Test 11: Internal Battery

Electrical Safety Data Form

Performance Verification Data Form

Complete Parts List

Recommended Inventory Parts List

Ventilator Chassis

Pneumatics

Electronics

Control settings

Patient data

Alarms

Menu window settings

[Operator-accessible diagnostic mode functions](#)

[Physical characteristics](#)

[Environmental specifications](#)

[Pneumatic specifications](#)

[Electrical specifications](#)

[Other specifications](#)

[Contact Information](#)

[Downloading Ventilator Software](#)

[Installing Ventilator Options](#)

[Reinitiate a Software Package](#)

[Remote Troubleshooting](#)

[Index](#)

[Other ManualsLib Projects](#)

PHILIPS

Respironics V60 Ventilator

Service Manual



For Technical Support and Customer Service, contact:

USA and Canada: 1-800-345-6443 (toll free) or 724-387-4000
Respironics Europe, Africa, Middle East: +33-1-47-52-30-00
Respironics Asia Pacific: +852-3194-2280
Facsimile: 724-387-5012

United States of America

Respironics California, Inc.
2271 Cosmos Court
Carlsbad, CA 92011
USA

Email and Web Addresses

service@respironics.com
clinical@respironics.com
www.respironics.com

Authorized European Representative

Respironics Deutschland GmbH
Gewerbestrasse 17
D-82211 Herrsching
Germany
+49-8-15-29-30-60

Copyright© 2009 Respironics California, Inc. and its affiliates.
All rights reserved.

This work is protected under Title 17 of the United States copyright code and is the sole property of Respironics California, Inc. No part of this document may be copied or otherwise reproduced, or stored in any electronic information retrieval system, except as specifically permitted under United States copyright law, without the prior written consent of Respironics California, Inc.

Table of Contents

1	Introduction and Intended Use	1-1
1.1	Intended Use	1-2
1.2	Recommended Test Equipment, Tools, and Supplies	1-3
1.3	Where to Go for Help	1-5
2	Warnings and Cautions	2-1
2.1	General	2-1
2.2	Preparing for Ventilation	2-4
2.3	Operation	2-6
2.4	Alarms and Messages	2-6
2.5	Care and Maintenance	2-6
2.6	First-Time Installation	2-7
2.7	Communications Interface	2-7
2.8	Diagnostic Mode	2-7
3	Theory of Operation	3-1
3.1	Pneumatics	3-1
3.1.1	Air Inlet	3-2
3.1.2	Air Inlet Filter	3-2
3.1.3	Air Flow Sensor	3-3
3.1.4	Machine and Proximal Pressure Transducers	3-3
3.1.5	Barometric Pressure Transducer	3-3
3.1.6	Oxygen Pressure Transducer	3-3
3.1.7	Manifold, Oxygen Inlet Filter, Filter Element	3-4
3.1.8	Oxygen Solenoid Valve	3-4
3.1.9	Oxygen Flow Sensor	3-4
3.1.10	Blower	3-4
3.1.11	Solenoid Valves	3-5
3.2	Electronics	3-6
3.2.1	Power management (PM) PCBA	3-7
3.2.2	Power Supply	3-7
3.2.3	Internal Battery	3-7
3.2.4	CPU PCBA	3-8
3.2.5	Motor Controller (MC) PCBA	3-10
3.2.6	Data Acquisition (DA) PCBA	3-10
3.2.7	Flow Sensors	3-10

Table of Contents

3.2.8	User Interface	3-11
3.2.9	LCD Assembly	3-11
3.2.10	Backlight Inverter PCBA	3-11
3.2.11	Touch Screen Assembly	3-12
3.2.12	Nav-Ring Assembly (Rotary Adjustment)	3-12
3.2.13	Power Switch Overlay	3-12
3.2.14	Switch PCBA	3-12
3.2.15	UI PCBA	3-13
3.3	Electronic Signal Paths	3-14
4	Periodic Maintenance	4-1
4.1	Annual Preventive Maintenance Instructions	4-2
5	Diagnostic Mode and Troubleshooting	5-1
5.1	System Settings	5-2
5.1.1	Selecting a Language	5-3
5.1.2	Setting Date and Time	5-5
5.1.3	Restoring Default Settings	5-6
5.1.4	Selecting Pressure Units	5-7
5.1.5	Enabling Software Options	5-8
5.1.6	Baud Rate	5-9
5.2	Service	5-10
5.2.1	Viewing Ventilator Information	5-11
5.2.2	Pneumatic Controls	5-12
5.2.3	Output Controls	5-13
5.2.4	Miscellaneous	5-14
5.3	Touch Screen Calibration	5-18
5.4	Diagnostic Codes, Alarms, and Troubleshooting	5-19
5.5	Miscellaneous Troubleshooting Tips	5-31
6	Reports and Software Downloads	6-1
6.1	Setting Up the Service PC	6-1
6.1.1	Setting Up the Serial Interface Using HyperTerminal	6-2
6.1.2	Setting Up the Serial Interface Using Tera Term	6-6
6.2	Generating a Diagnostic Report (DRPTA)	6-17
6.3	Clearing the Significant Event Log	6-20
6.4	Downloading Ventilator Software	6-21
6.5	Programming the Ventilator Serial Number and Power-On Hours	6-21
6.5.1	Programming the Ventilator Serial Number	6-21
6.5.2	Programming Ventilator Power-On Hours	6-23

7	Component Removal/Installation	7-1
7.1	Disconnecting Power	7-2
7.2	Air Inlet Filter	7-3
7.3	Internal Battery	7-3
7.4	Top Cover	7-5
7.5	AC Inlet	7-6
7.6	Fan	7-7
7.7	Oxygen Inlet	7-8
7.8	Motor Controller (MC) PCBA	7-9
7.9	Separating the UI from the Base	7-10
7.10	Front Panel	7-11
7.11	Gas Outlet Port	7-12
7.12	UI Retainer	7-13
7.13	Proximal Pressure Port	7-14
7.14	Speakers	7-15
7.15	Power Management (PM) PCBA	7-16
7.16	Power Supply	7-17
7.17	CPU PCBA	7-18
7.18	Real-Time Clock Battery	7-19
7.19	Left Side Wall	7-20
7.20	Gas Delivery Subsystem (GDS)	7-21
7.21	Right Side Wall	7-23
7.22	Oxygen Inlet Filter	7-24
7.23	Data Acquisition (DA) PCBA	7-25
7.24	Air and Oxygen Flow Sensor Assembly	7-27
7.25	Oxygen Solenoid Valve	7-28
7.26	Solenoid Valves	7-29
7.27	Blower	7-30
7.28	Opening the User Interface (UI)/ Rear Bezel	7-31
7.29	Power Switch Overlay	7-32
7.30	Switch PCBA	7-33
7.31	Nav-Ring Assembly	7-34
7.32	Front Bezel, Touch Screen	7-35
7.33	LCD	7-36
7.34	User Interface (UI) PCBA	7-38
7.35	Backlight Inverter PCBA	7-39
7.36	LCD Tray	7-40
7.37	Bottom Feet	7-41
7.38	Labels	7-42

Table of Contents

8	Performance Verification	8-1
8.1	Required Test Equipment	8-5
8.2	Preliminary Cleaning, Inspection and Setup	8-7
8.3	View and Record Ventilator Information	8-8
8.4	Pneumatic Calibration Analyzer Setup	8-9
8.4.1	Measurement Selection Screen	8-9
8.4.2	Averaging Setup Menu	8-10
8.4.3	Trigger Options	8-11
8.4.4	Configurations Menu	8-12
8.5	Performance Verification Procedures	8-15
8.5.1	Electrical Safety (Test 1)	8-15
8.5.2	Leak Tests (Test 2)	8-17
8.5.3	Controls (Test 3)	8-20
8.5.4	Pressure Accuracy (Test 4)	8-21
8.5.5	Air Delivery/Flow Accuracy (Test 5)	8-24
8.5.6	Oxygen Flow Accuracy (Test 6)	8-27
8.5.7	Oxygen Accuracy (Test 7)	8-29
8.5.8	S/T Performance (Test 8)	8-31
8.5.9	Alarms (Test 9)	8-33
8.5.10	Power Fail (Test 10)	8-35
8.5.11	Internal Battery (Test 11)	8-36
8.6	Returning Ventilator to Operation	8-37
8.7	Performance Verification Troubleshooting/Repair	8-37
8.7.1	Test 1: Electrical Safety	8-38
8.7.2	Test 2: Leak Tests	8-38
8.7.3	Test 3: Controls	8-39
8.7.4	Test 4: Pressure Accuracy	8-40
8.7.5	Test 5: Air Delivery/Flow Accuracy	8-40
8.7.6	Test 6: Oxygen Flow Accuracy	8-41
8.7.7	Test 7: Oxygen Accuracy	8-41
8.7.8	Test 8: S/T Performance	8-41
8.7.9	Test 9: Alarms	8-42
8.7.10	Test 10: Power Fail	8-42
8.7.11	Test 11: Internal Battery	8-43
8.8	Electrical Safety Data Form	8-44
8.9	Performance Verification Data Form	8-45

9	Replacement Parts List	9-1
9.1	Complete Parts List	9-1
9.2	Recommended Inventory Parts List	9-7
9.3	Ventilator Chassis	9-10
9.4	Pneumatics	9-12
9.5	Electronics	9-13
10	Specifications	10-1
10.1	Control settings	10-1
10.2	Patient data	10-3
10.3	Alarms	10-4
10.4	Menu window settings	10-4
10.5	Operator-accessible diagnostic mode functions	10-5
10.6	Physical characteristics	10-5
10.7	Environmental specifications	10-6
10.8	Pneumatic specifications	10-6
10.9	Electrical specifications	10-7
10.10	Other specifications	10-8
10.11	Contact Information	10-8
Appendix A	Respi-Link	A-1
A.1	Downloading Ventilator Software	A-1
A.2	Installing Ventilator Options	A-6
A.3	Reinitiate a Software Package	A-8
A.4	Remote Troubleshooting	A-13
Appendix B	Field Communications	B-1
	Index	Index-1

Table of Contents

(This page is intentionally blank.)

Chapter 1. Introduction and Intended Use

The V60 ventilator is a microprocessor-controlled, positive pressure ventilator assist system. The ventilator provides noninvasive and invasive ventilatory support for spontaneously breathing adult and pediatric patients.

The ventilator has a variety of modes and monitoring capabilities to assist in assessing performance and patient-to-ventilator synchrony. The safety features include in-depth alarms and a variety of integrated safety and self-diagnostic features. Many system functions are automatically checked at startup and during operation.

The ventilator includes a touch screen user interface (UI) and navigation ring (nav-ring) that allows the operator to select ventilator and alarm settings and displays of ventilator and patient data.

The ventilator is designed to be upgradeable, and features communications capabilities and an internal battery backup option.

Read this manual thoroughly before performing service or maintenance on the V60 ventilator. This manual includes advanced troubleshooting, calibration, and maintenance instructions for the ventilator. All maintenance and repair work should be performed by qualified biomedical technicians who have appropriate training and authorization to provide maintenance, repair, and service for the V60.

Review the operating instructions for the V60 ventilator before running tests, checking operational readiness, or initiating patient use. These instructions include important information about ventilator safety and operation.

For additional information about accessories or related equipment, such as humidifiers and remote alarm systems, refer to the appropriate instruction manual prior to operating the V60 ventilator. Review the applicable warnings and cautions in the *V60 User Manual* before operating the ventilator.

Introduction and Intended Use

1.1 Intended Use

The Respironics V60 ventilator is an assist ventilator that is intended to augment patient breathing. It is intended for spontaneously breathing individuals who require mechanical ventilation: patients with respiratory failure, chronic respiratory insufficiency, or obstructive sleep apnea in a hospital or other institutional settings under the direction of a physician.

The ventilator is intended to support pediatric patients weighing 20 kg (44 lb.) or greater to adult patients. It is also intended for intubated patients meeting the same selection criteria as the noninvasive applications. The ventilator is intended to be used by qualified medical professionals such as physicians, nurses, and respiratory therapists. The ventilator is intended to be used only with various combinations of Respironics recommended patient circuits, interfaces (masks), humidifiers, and other accessories.

1.2 Recommended Test Equipment, Tools, and Supplies

Table 1-1 lists the recommended tools, test equipment, and materials required to service and maintain the V60 ventilator.

Table 1-1: Recommended Test Equipment, Tools, and Materials

Description	Manufacturer and Model
Test Equipment	
Digital multimeter (DMM) accurate to three decimal places	Local Supplier
Electrical safety analyzer	Dale LT 5440 or equivalent
Pneumatic calibration analyzer capable of measuring low pressure (cmH ₂ O), flow rate (LPM), and volume (liters)	Respironics P/N 1040311 or equivalent
Temperature/humidity monitor	Fisher Scientific 11661-14 or equivalent
Test lung	IngMar QuickLung or equivalent
Service Tools and Supplies	
V60 Service Kit, which includes:	Respironics P/N 1054291
Adapter, 22-mm OD, both ends	Respironics P/N 1002505
Adapter, 25-pin to 9-pin	Respironics P/N 1058403
Adapter, torque, cap/collar	Respironics P/N 1056005
BiPAP test adapter, 0.25-in.	Respironics P/N 332353
Cable, null modem	Respironics P/N 1022815
Cable, TTL communications	Respironics P/N 1058778
Circuit tube, 18-in. smooth-bore (qty. 2)	Respironics P/N 1000060
Coupling, straight, silicone	Respironics P/N 500-1000-43
Forceps, locking, red plastic	Respironics P/N 1058430
Plug, low-pressure	Respironics P/N 1058270
Plug, tapered $\frac{23}{32}$ - $\frac{61}{64}$ in., silicone (qty. 2)	Respironics P/N 1055322
Plug, tapered $\frac{9}{16}$ - $\frac{3}{4}$ in., silicone	Respironics P/N 1055323
Pressure pick-off port (oxygen enrichment attachment SINGL)	Respironics P/N 312710
Proximal pressure line tubing	Respironics P/N 312114
Remote alarm test cable	Respironics P/N 1027818
Remote alarm test cable adapter	Respironics P/N 1027817

Introduction and Intended Use

Table 1-1: Recommended Test Equipment, Tools, and Materials

Description	Manufacturer and Model
Syringe, system leak test	Respironics P/N 1058271
Valve, ball	Respironics P/N 1058431
Valve, oxygen/regulator shut-off	Respironics P/N 1058380
Whisper Swivel II	Respironics P/N 332113
Adapter, USB to serial	Respironics P/N 1022895 or equivalent
Cleaning cloth	Local supplier
Fitting, system leak test syringe (replacement)	Respironics P/N 1060263
Isopropyl alcohol	Local supplier
Lubricant, KRYTOX GPL 226	Respironics P/N 1021021 or equivalent
Metric hex key set (rounded ends), 1.5 to 4 mm	Local supplier
Mild detergent or antiseptic wipes	Local supplier
Needle nose pliers	Local supplier
PC or laptop (required for downloading software and capturing diagnostic codes)	Required: Windows XP operating systems, serial port, and USB port
Pliers	Local supplier
Screwdriver, #0 Phillips	Local supplier
Screwdriver, #1 Phillips	Local supplier
Screwdriver, #2 Phillips	Local supplier
Screwdriver, #3 Phillips	Local supplier
Screwdriver, pen size, Phillips	Local supplier
Screwdriver, pen size, slotted	Local supplier
Socket, deep, 5/16-in.	Local supplier
Socket, deep, 9/16-in.	Local supplier
Torque driver capable of 11.2 to 283 N cm / 1 to 25 in.-lbf	Local supplier
Torque driver capable of 226 to 1130 N cm/ 20 to 100 in.-lbf	Local supplier
Vacuum, ESD-safe	3M Model 497-AJM or equivalent
Workstation, antistatic	3M Model 725 or equivalent

1.3 Where to Go for Help

For Technical Support and Customer Service, contact:

USA and Canada: 800-345-6443 or 724-387-4000

Respironics Europe, Africa, Middle East: +33-1-47-52-30-00

Respironics Asia Pacific: +852-3194-2280

Facsimile: +1-724-387-5012

(This page is intentionally blank.)

Chapter 2. Warnings and Cautions

Before servicing the Respironics V60 ventilator, read and understand this service manual, especially safety considerations. These safety considerations are for reference only, and are not intended to supersede your institution's protocol for service or safe use of noninvasive ventilation.

The instructions in this manual are primarily reserved for use by a qualified service technician.

WARNING: Alerts the user to the possibility of injury, death, or other serious adverse reactions associated with the use or misuse of the device.

CAUTION: Alerts the user to the possibility of a problem with the device associated with its use or misuse, such as device malfunction, device failure, damage to the device, or damage to other property.

NOTE: Emphasizes information of particular importance.

2.1 General

WARNING: An alternative means of ventilation shall be available whenever the ventilator is in use. If a fault is detected in the ventilator, disconnect the patient from it and immediately start ventilation with such a device. The ventilator must be removed from clinical use and serviced by Respironics-authorized service personnel.

WARNING: Use the Respironics V60 ventilator on spontaneously breathing patients only. It is an assist ventilator and is intended to augment the ventilation of a spontaneously breathing patient. It is not intended to provide the total ventilatory requirements of the patient.

WARNING: We do not recommend you use the Respironics V60 ventilator on patients who require ventilation at predetermined tidal volumes. The ventilator provides continuous positive airway pressure (CPAP) and positive pressure ventilation (S/T, PCV, and AVAPS) and is indicated for assisted ventilation only. These modes do not provide ventilation with guaranteed tidal volume delivery.

WARNING: We do not recommend you use AVAPS on patients who require rapid and frequent IPAP adjustments to maintain a consistent tidal volume. AVAPS, a volume targeted mode, changes the IPAP setting in order to achieve the target tidal volume. During AVAPS setup, there may be a period of time before the target tidal volume is achieved. AVAPS is ideal for more stabilized patients.

Warnings and Cautions

- WARNING:** To reduce the risk of CO₂ rebreathing, make sure EPAP pressures and exhalation times are sufficient to clear all exhaled gas through the exhalation port. In noninvasive ventilation continuous air flow through the port flushes exhaled gases from the circuit. The ability to completely exhaust exhaled gas from the circuit depends on the EPAP setting and I:E ratio. Higher tidal volumes further increase the volume of CO₂ rebreathed by the patient.
- WARNING:** To reduce the risk of CO₂ rebreathing, monitor the patient for changes in respiratory status at the start of ventilation and with each change in ventilator settings, circuit configuration, or patient condition. Pay attention to ventilator alarms that warn of increased CO₂ rebreathing risk.
- WARNING:** Be aware of the possibility of contamination from patient exhalate being exhausted into the room through the exhalation port.
- WARNING:** To ensure accuracy of oxygen administration and to monitor for the presence of contamination (incorrect gas connected), use an external oxygen monitor to verify the oxygen concentration in the delivered gas.
- WARNING:** To reduce the risk of fire, use the ventilator in well-ventilated areas away from flammable anesthetics. Do not use in a hyperbaric chamber or other similarly oxygen-enriched environments. Do not use near an open flame.
- WARNING:** To reduce the risk of electric shock from liquid entering the device, do not put a container filled with a liquid on the ventilator.
- WARNING:** To reduce patient risk of hypoxemia, keep free-flowing oxygen away from air inlet of ventilator.
- WARNING:** Connect to the ventilator only items that are specified as part of or compatible with the ventilator system. Additional equipment connected to medical electrical equipment must comply with the respective IEC or ISO standards. Furthermore, all configurations shall comply with the requirements for medical electrical systems (see IEC 60601-1-1 or clause 16 of edition 3 of IEC 60601-1, respectively). Anybody connecting additional equipment to medical electrical equipment configures a medical system and is therefore responsible for ensuring that the system complies with the requirements for medical electrical systems. Also be aware that local laws may take priority over the above mentioned requirements. If in doubt, consult Respirationics.
- WARNING:** To reduce the risk of fire, explosion, leakage, or other hazard, take these precautions with respect to the battery:
- Do not attempt to disassemble, open, drop, crush, bend or deform, insert foreign objects into, puncture, or shred the battery pack; modify or remanufacture it; immerse or expose it to water or other liquids; expose it to fire, excessive heat (including soldering irons); or put it in a microwave oven.
 - Replace the battery only with another battery specified by the manufacturer.
 - Follow all instructions for proper use of the battery.
 - Do not short-circuit the battery or allow metallic or conductive objects to contact the battery connector housing.
 - Use the battery with the Respirationics V60 ventilator only.

Warnings and Cautions

- WARNING:** The nurse call/remote alarm should be considered a backup to the ventilator's primary alarm system.
- WARNING:** To ensure that the alarm will be heard, make sure the alarm loudness is adequate and avoid blocking the alarm speakers beneath the ventilator.
- CAUTION:** Federal law (USA) restricts this device to sale by or on the order of a physician.
- CAUTION:** The Respironics V60 ventilator is designed to operate in the temperature range of 5 to 40 °C (41 to 104 °F). To minimize the risk of overheating the device, do not operate adjacent to heaters or other heat sources.
- NOTE:** The displays shown in this manual may not exactly match what you see on your own ventilator.
- NOTE:** Pressures are indicated on the ventilator in cmH₂O. Millibars and hectopascals (hPa) are used by some institutions instead. Since 1 millibar equals 1 hPa, which equals 1.016 cmH₂O, the units may be used interchangeably.
- NOTE:** The ventilator is not intended for use as an ambulance transport ventilator or as an Automatic Transport Ventilator as described by the American Hospital Association and referenced by the FDA. It is intended to allow the patient to be transported within the hospital setting using a cart to move the ventilator.
- NOTE:** When attachments or other components or subassemblies are added to the ventilator breathing system, the pressure gradient across the ventilator breathing system, measured with respect to the ventilator outlet, may increase.
- NOTE:** The Respironics V60 ventilator parts that have patient contact are free of latex.
- NOTE:** If an alarm persists for no apparent reason, discontinue ventilator use and contact Respironics.
- NOTE:** If you detect any unexplained changes in the performance or visual displays of the ventilator, discontinue ventilator use and contact Respironics.
- NOTE:** The Respironics V60 ventilator does not support automatic record keeping.

2.2 Preparing for Ventilation

- WARNING:** To ensure the correct performance of the ventilator and the accuracy of patient data, we recommend you use only Respironics-approved accessories with the ventilator.
- WARNING:** To prevent possible asphyxia and to reduce the risk of CO₂ rebreathing, take these precautions with respect to mask and exhalation port use:
- Use only a mask with an exhalation port or a nasal mask for noninvasive ventilation.
 - Do not occlude the exhalation port.
 - Turn on the ventilator and verify that the port is operational before application. Pressurized gas from the ventilator should cause a continuous flow of air to exhaust from the leak port, flushing exhaled gas from the circuit.
- WARNING:** Never leave the mask on the patient while the ventilator is not operating. When the ventilator is not operating, the exhalation port does not allow sufficient exhaust to eliminate CO₂ from the circuit. Substantial CO₂ rebreathing may occur.
- WARNING:** To ensure normal air circulation and exchange, do not cover or block the ports on the ventilator or ventilator circuit. Do not block the air inlet panel on the right side of the ventilator.
- WARNING:** To prevent possible patient injury and possible water damage to the ventilator, make sure the humidifier is set to appropriate temperature and humidification settings.
- WARNING:** To prevent the possibility of inadequate humidification, pay close attention to the humidifier's functioning when operating the ventilator at an ambient temperature > 30 °C (86 °F). The ventilator warms the air delivered to the patient above ambient temperature, which may impair the humidifier's performance.
- WARNING:** To reduce the risk that the patient will aspirate condensed water from the breathing circuit, position any humidifier lower than both the ventilator and the patient.
- WARNING:** To prevent possible patient injury and equipment damage, do not turn the humidifier on until the gas flow has started and is regulated. Starting the heater or leaving it on without gas flow for prolonged periods may result in heat build-up, causing a bolus of hot air to be delivered to the patient. Circuit tubing may melt under these conditions. Turn the heater power switch off before stopping gas flow.
- WARNING:** To reduce the risk of fire, use only patient circuits intended for use in oxygen-enriched environments. Do not use antistatic or electrically conductive tubing.
- WARNING:** To prevent patient or ventilator contamination, recommend you use a Respironics-approved main flow bacteria filter on the patient gas outlet port. Filters not approved by Respironics may degrade system performance.

Warnings and Cautions

- WARNING:** To reduce the risk of bacterial contamination or damage, handle bacteria filters with care.
- WARNING:** To reduce the risk of strangulation from patient tubing, use a tubing support arm and secure the proximal pressure line with clips.
- WARNING:** To reduce the risk of electric shock, connect the ventilator to an AC supply mains with protective earth only.
- WARNING:** Do not use extension cords, adapters, or power cords with the ventilator that are not approved by Respirationics.
- WARNING:** To prevent unintentional disconnection of the power cord, always use the correct, Respirationics-supplied power cord and lock it into place with the power cord retainer before you switch the ventilator on. The retainer is designed to hold the connector end of the Respirationics-supplied cord securely in place.
- WARNING:** To reduce the risk of electric shock, regularly inspect the AC power cord and verify that it is not frayed or cracked.
- WARNING:** To reduce the risk of strangulation, route the power cord to avoid entanglement.
- WARNING:** To reduce the risk of power failure, pay close attention to the battery's charge level. The battery's operation time is approximate and is affected by ventilator settings, discharge and recharge cycles, battery age, and ambient temperature. Battery charge is reduced at low ambient temperatures or in situations where the alarm is continuously sounding.
- WARNING:** To ensure the ventilator's safe operation, always run the full preoperational check described in the operator's manual before using the ventilator on a patient. If the ventilator fails any tests, remove it from clinical use immediately. Do not use the ventilator until necessary repairs are completed and all tests have passed.
- WARNING:** To prevent possible patient injury, disconnect the patient from the ventilator before running the preoperational check. Make sure another source of ventilatory support is available.
- WARNING:** To prevent possible patient injury due to nonannunciating alarms, verify the operation of any remote alarm device before use.
- CAUTION:** To prevent possible damage to the ventilator, ensure that the connection to the oxygen supply is clean and unlubricated, and that there is no water in the oxygen supply gas.
- CAUTION:** For 120 V equipment, grounding reliability can only be achieved when it is connected to an equivalent receptacle marked "hospital only" or "hospital grade."

Warnings and Cautions

2.3 Operation

WARNING: To prevent possible patient injury, avoid setting alarm limits to extreme values, which can render the alarm system useless.

2.4 Alarms and Messages

WARNING: If AC power fails and the backup battery is not installed or is depleted, an audible and visual alarm annunciates for at least 2 minutes. Immediately discontinue ventilator use and secure an alternative means of ventilation. As in most ventilators with passive exhalation ports, when power is lost, sufficient air is not provided through the circuit and exhaled air may be rebreathed.

2.5 Care and Maintenance

WARNING: **WARNING:** To reduce the risk of electric shock, power down the ventilator and disconnect it from AC power before cleaning or servicing it.

WARNING: **WARNING:** To prevent patient or ventilator contamination, inspect and replace the main flow bacteria filter between patients and at regular intervals (or as stated by the manufacturer).

WARNING: **WARNING:** To prevent possible patient injury, inspect and verify the proper operation of the exhalation port regularly during use.

CAUTION: Do not attempt to sterilize or autoclave the ventilator.

CAUTION: To prevent possible damage to the ventilator, use only those cleaning agents listed in this manual.

CAUTION: To prevent possible damage to the touchscreen, take care when cleaning it. Do not drip water and/or soap solution. After cleaning and rinsing, remove all moisture with a dry, soft cloth. Never clean the touchscreen with an abrasive brush or device, since this will cause irreparable damage.

CAUTION: To avoid introducing foreign matter into the ventilator and to ensure proper system performance, change the air inlet filter at regular intervals (or as stipulated by your institution).

CAUTION: To ensure proper system performance, use a Respironics-approved air inlet filter.

CAUTION: Because some environments cause a quicker collection of lint and dust than others, inspect the filters more often when needed. The air inlet filter should be replaced; the cooling fan filter should be cleaned.

CAUTION: To prevent possible damage to the ventilator, always ship it with the original packing material. If the original material is not available, contact Respironics to order replacements.

2.6 First-Time Installation

WARNING: Never attempt to disconnect or reconnect the battery during operation.

CAUTION: To prevent possible damage to the ventilator, always secure it to its stand or securely place it on a flat, stable surface that is free of dirt and debris. Do not use the ventilator adjacent to, or stack it with, other equipment.

2.7 Communications Interface

WARNING: Connect to the ventilator only items that are specified as part of or compatible with the ventilator system. Additional equipment connected to medical electrical equipment must comply with the respective IEC or ISO standards. Furthermore, all configurations shall comply with the requirements for medical electrical systems (see IEC 60601-1-1 or clause 16 of edition 3 of IEC 60601-1, respectively). Anybody connecting additional equipment to medical electrical equipment configures a medical system and is therefore responsible for ensuring that the system complies with the requirements for medical electrical systems. Also be aware that local laws may take priority over the above mentioned requirements. If in doubt, consult Respirationics.

WARNING: It is the responsibility of the end user to validate the compatibility and use of information transmitted from the ventilator with the device to be connected to the ventilator.

WARNING: The data provided through the communications interface is for reference only. Decisions for patient care should be based on the clinician's observations of the patient.

WARNING: To prevent possible patient injury due to nonannunciating alarms, verify the operation of any remote alarm device before use.

WARNING: To ensure the functionality of the remote alarm, connect only Respirationics-approved cables to the remote alarm port.

CAUTION: The remote alarm port is intended to connect only to an SELV (safety extra-low voltage and ungrounded system with basic insulation to ground), in accordance with IEC 60601-1. To prevent damage to the remote alarm, make sure the signal input does not exceed the maximum rating of 24 VAC or 36 VDC at 500 mA with a minimum current of ≥ 1 mA.

2.8 Diagnostic Mode

WARNING: To prevent possible patient injury, do not enter the diagnostic mode while a patient is connected to the ventilator. Verify that the patient is disconnected before proceeding.

(This page is intentionally blank.)

Chapter 3. Theory of Operation

The V60 ventilator is a microprocessor-controlled gas flow control and monitoring system that can deliver air and oxygen to augment or replace the work normally performed by the patient's respiratory system. The ventilator uses electromechanical control circuits, flow and pressure monitors, and software programs to deliver pressure controlled breaths.

The ventilator includes a user interface (UI), internal blower, and gas delivery subsystem (GDS) that mixes air and oxygen. The ventilator can operate from a 40 to 87 psig (276 to 600 kPa) medical grade oxygen source for enriched oxygen operation. The internal power supply that can operate from mains (100 to 240 V AC 50/60 Hz) or internal battery (14.4 V DC) power. The ventilator also includes several communications interfaces.

Schematic diagrams of the V60 ventilator are available upon request.

3.1 Pneumatics

The pneumatic subsystem delivers and monitors pressurized gas to the patient in response to commands from the CPU subsystem. The pneumatic subsystem includes the:

- Manifold
- Blower
- Oxygen solenoid valve
- Air and oxygen flow sensors
- Pressure transducers
- Solenoid valves
- Motor controller (MC) PCBA
- Data acquisition (DA) PCBA

The ventilator uses ambient air and high-pressure oxygen. Air enters through an inlet filter. Oxygen enters through a high-pressure inlet, and a proportional valve provides the operator-set concentration. The system mixes the air and oxygen, pressurizes it in the blower, and then regulates it to the user-set pressure. To do this, the ventilator compares the proximal (patient) pressure measurement with the ventilator outlet (machine) pressure, and adjusts the machine pressure to compensate for the pressure drop across the inspiratory filter, patient circuit, and humidifier. This helps ensure accurate and responsive pressure delivery and leak compensation.

The ventilator delivers gas to the patient through a main flow (inspiratory) bacteria filter, a single-limb patient breathing circuit, a humidification device (optional), and a patient interface such as a mask or ET tube. A pressure tap

Chapter 3: Theory of Operation

proximal to the patient is used to monitor patient pressure. The internal exhalation port continually clears gas from the ventilator airway to ensure delivery of an accurate oxygen mixture.

Figure 3-1 shows a pneumatic schematic of the V60 ventilator.

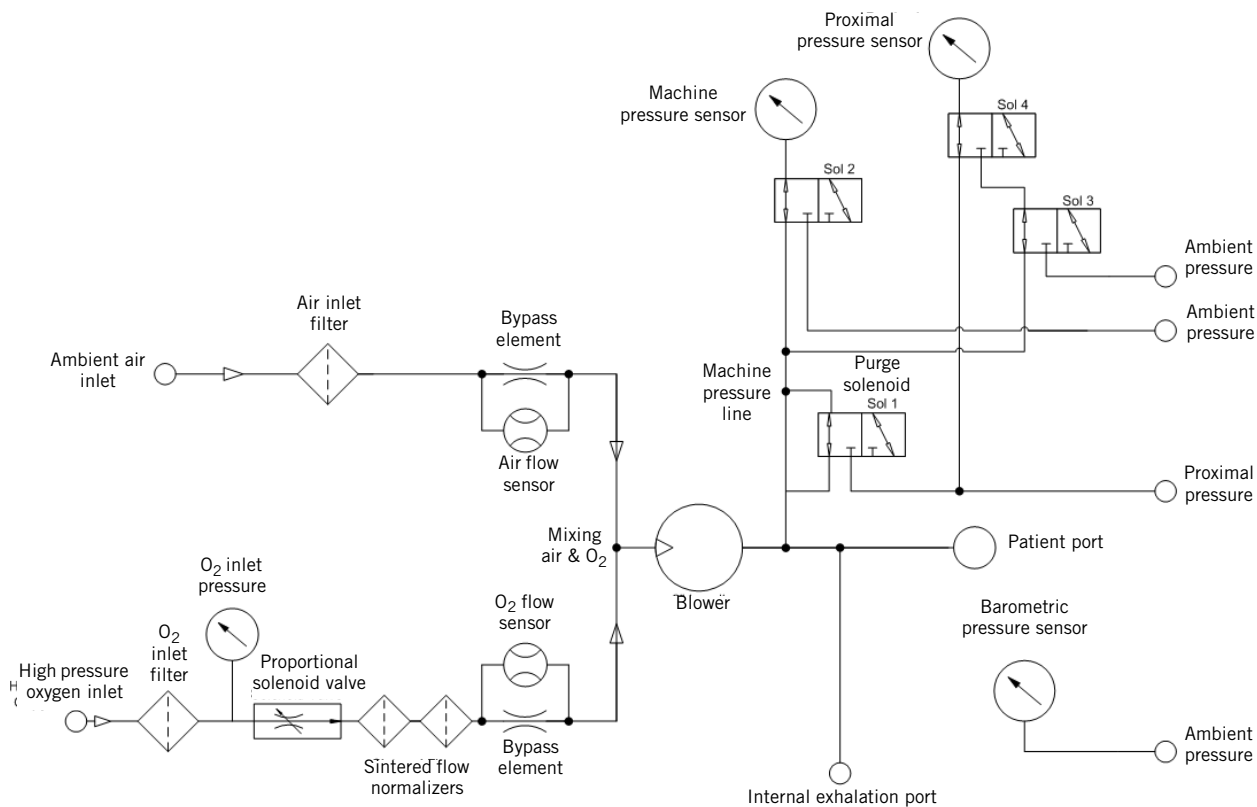

Figure 3-1: V60 Ventilator Pneumatic Subsystem Schematic



Air inlet

3.1.1 Air Inlet

Ambient air is entrained through the *air inlet*.



Air inlet filter

3.1.2 Air Inlet Filter

The *air inlet filter* is designed to filter 5-micron particles at 70% efficiency at 150 SLPM flow.

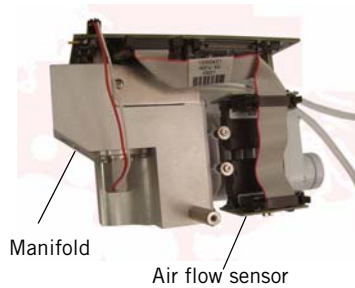

3.1.3 Air Flow Sensor

The *air flow sensor* measures a subset (bypass flow) of total flow in the pneumatic air path and interpolates the measurements according to constants that are calculated during gas delivery subsystem (GDS) calibration. The air flow sensor also helps provide closed-loop control of gas flow during oxygen blending.

3.1.4 Machine and Proximal Pressure Transducers

The *machine and proximal pressure transducers* on the DA PCBA measure the machine and proximal pressure over a range of -20 to +65 cmH₂O.

3.1.5 Barometric Pressure Transducer

The *barometric pressure transducer* on the DA PCBA measures barometric pressure over a range of 525 to 850 mmHg.

3.1.6 Oxygen Pressure Transducer

The *oxygen pressure transducer* on the DA PCBA measures inlet pressure over

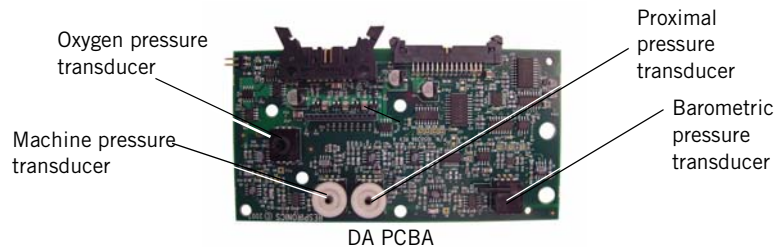

a range of 0 to 87 psig. An alarm results if oxygen supply pressure is below 40 psig (276 kPa) or above 92 psig (634 kPa).

Chapter 3: Theory of Operation

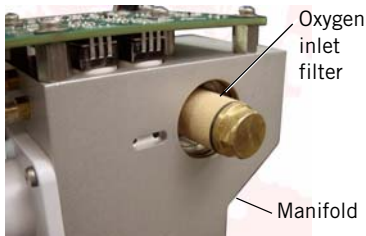

3.1.7 Manifold, Oxygen Inlet Filter, Filter Element

The *manifold* includes a connection for the oxygen inlet, allowing country-specific oxygen connections to be attached to the manifold. The manifold provides the pneumatic interfaces to the air inlet, oxygen inlet, blower inlet, and proximal and machine pressure lines.

The *oxygen inlet filter* removes 5-micron particles from the oxygen gas supply. A 40-micron sintered bronze *filter element* acts to reduce turbulence in the oxygen flow. The 40-micron oxygen breather vent reduces noise in the oxygen flow.

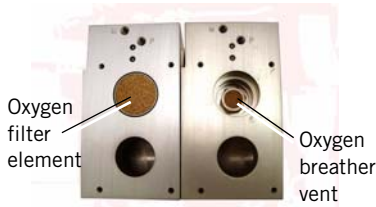

3.1.8 Oxygen Solenoid Valve

The *oxygen solenoid valve* and valve driver circuitry control the flow of oxygen according to the set O_2 and flow. The oxygen solenoid valve is closed when there is a loss of power or system reset.

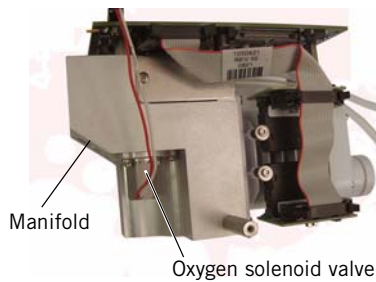

3.1.9 Oxygen Flow Sensor

The *oxygen flow sensor* measures a subset (bypass flow) of the total flow. These measurements are interpolated according to constants that are calculated during GDS calibration. Together, the oxygen solenoid valve and flow sensor provide closed-loop control for delivered oxygen flow.

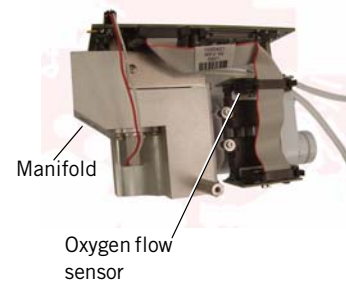

3.1.10 Blower

The *blower* is controlled by the MC PCBA, and generates flow and pressure for the system. The blower includes an impeller, housing, and a three-phase brushless DC motor. The blower delivers a maximum pressure of less than 125 cmH₂O in a dead-head condition, can accelerate from 10,000 to 22,500 revolutions per minute (RPM) in 120 msec from a nominal 5- to 25-cmH₂O pressure rise. Maximum motor speed is approximately 40,000 RPM. The blower motor has internal Hall Effect sensors that are monitored by the MC PCBA and measure impeller speed.



3.1.11 Solenoid Valves

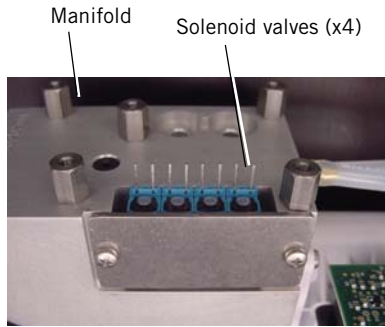

Four *solenoid valves* are mounted on the manifold and controlled by the DA PCBA. These three-way autozero solenoids include SOL1 (purge solenoid), SOL2 and SOL4 (machine pressure autozero solenoids), and SOL3 and SOL4 (proximal pressure autozero solenoids).

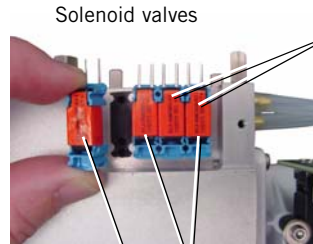

SOL3, SOL4: Proximal pressure autozero solenoids. SOL4: Also connects machine pressure to the proximal pressure transducer during autozero.

SOL2, SOL4: Machine pressure autozero solenoids.

SOL1: Purge solenoid, uses the machine pressure line to purge the proximal pressure line.

Chapter 3: Theory of Operation

3.2 Electronics

The electronics system provides software-based control and monitoring, power management, user input, display, subsystem I/O, external communication, and alarms. The electronics system includes a Cirrus EP9307 microcontroller for control and monitor processing.

Control tasks include breath delivery, patient data calculation, and alarm detection/response. Monitoring tasks include controlling the LCD, front panel keys and indicators, inputs, and primary alarm output. An independent watchdog control provides safety monitoring.

The electronics system includes:

- Power management (PM) PCBA
- Power supply
- Internal battery
- CPU PCBA
- Motor controller (MC) PCBA
- Data acquisition (DA) PCBA
- Flow sensors
- User interface
- Liquid crystal display (LCD)
- Backlight inverter PCBA
- Touch screen assembly
- Nav-ring assembly
- Power switch overlay
- Switch PCB
- User interface (UI) PCBA



PM PCBA

3.2.1 Power management (PM) PCBA

- Battery charging and management circuitry
- Internal supply voltages (supply voltages: 3.3 V, 5 V, 12 V, 35 V).
- Fan power and tach monitoring.
- Backup alarm control circuitry, including power fail detection.
- Power switch control circuitry.
- System alarm and reset management.
- Electrical interfaces between the CPU PCBA, LCD, and the user interface (UI) PCBA.
- Includes an EEPROM for calibration data, board identification information, and PM PCBA power-on hours.



Power supply

3.2.2 Power Supply

- Provides ventilator and battery recharging power from AC line voltage.
- Converts AC line voltage (100 to 240 VAC, 50 to 60 Hz) into 24 VDC power.
- Includes input over-current, output over-voltage, and output current-limiting protection.



Internal battery

3.2.3 Internal Battery

- 14.4-V, 11.5-Ah lithium-ion battery has a run-time of at least six hours under normal conditions.
- Provides operating power when AC power is not available.
- Provides charge and temperature status to the PM PCBA.
- Internal circuitry monitors battery status, provides self-contained fault control features, and communicates this information to the PM PCBA.

Chapter 3: Theory of Operation



CPU PCBA

3.2.4 CPU PCBA

- Microprocessor: once in a run state, the microprocessor can only be reset by a watchdog timeout or out-of-specification power condition. Monitors operation of the ventilator and controls delivery of air and oxygen to the patient. Verifies safe ventilator operation.
- Flash memory: 8 MB program storage.
- RAM: 8 MB for program execution and volatile data storage.
- EEPROM: 4 KB of storage for board-specific information (including operating hours, time since last service, serial numbers, part numbers, and software and hardware revisions).
- Watchdog timer: disables the blower and oxygen flow if not strobed by software within a predefined time window that is independent of the CPU master clock. In addition, ensures that software is operating.
- Real-time clock (RTC): a time of day clock that provides the date and time to the ventilator, and is powered by a dedicated 3-V lithium coin cell battery.
- LCD interface supports a display of 1024 horizontal x 768 vertical pixels in 256 colors with a refresh rate of at least 50 Hz. The CPU PCBA controls LCD brightness by varying a control voltage over a range of 0 to 3.5 V (minimum to maximum brightness).
- Touch screen interface supports a five-wire type touch screen.
- Nav-ring rotary adjustment interface with a minimum resolution of 24 ticks per revolution.
- User key switches: interfaces to front panel keys.
- Alarm subsystem: includes a speaker driver circuit for the two main speakers, a backup piezo alarm, and a three-wire relay-controlled remote alarm interface (normal open, NO, or normal closed, NC) on the ventilator back panel.
- Blower speed monitor measures blower speeds from 3,000 to 50,000 RPM with 2% accuracy.
- Electrical interfaces to the power management (PM) and motor controller (MC) PCBAs.
- Two USB ports and an ethernet connection are designed for future enhancements. Table 3-1 summarizes hospital information system (HIS) RS-232 port pinout.

Table 3-1: V60 HIS Serial Communications Port Pinout

Pin	Signal	I/O	Description
1	HIS_RS232_SHLD	Power	HIS RS232 cable shield
2	HIS_RS232_TxD	Output	HIS RS232 transmit data output
3	HIS_RS232_RxD	Input	HIS RS232 receive data input
4	HIS_RS232_RTS	Output	HIS RS232 ready to send
5	HIS_RS232_CTS	Input	HIS RS232 clear to send
6	HIS_RS232_DSR	Input	HIS RS232 data set ready
7	HIS_SIG_RTN	Power	HIS RS232 signal common
8	PULSE_OX_IN	Input	Pulse oximeter analog input
9	HIS_DIG_IN0	Input	HIS digital input #0, 0-3.3 V digital logic level (0-5 V tolerant)
10	HIS_DIG_IN1	Input	HIS digital input #1, 0-3.3 V digital logic level (0-5 V tolerant)
11	HIS_ANALOG_IN00	Input	HIS analog input #0, 0-5.0 V analog voltage level
12	HIS_ANALOG_IN01	Input	HIS analog input #1, 0-5.0 V analog voltage level
13	HIS_SIG_RTN	Power	HIS RS232 signal common
14	HIS_DIG_IN2	Input	HIS digital input #2, 0-3.3 V digital logic level (0-5 V tolerant)
15	HIS_DIG_IN3	Input	HIS digital input #3, 0-3.3 V digital logic level (0-5 V tolerant)
16	HIS_DIG_OUT0	Output	HIS digital output #0, 0-3.3 V digital logic level
17	HIS_DIG_OUT1	Output	HIS digital output #1, 0-3.3 V digital logic level
18	HIS_DIG_OUT2	Output	HIS digital output #2, 0-3.3 V digital logic level
19	HIS_DIG_OUT3	Output	HIS digital output #3, 0-3.3 V digital logic level
20	HIS_RS232_DTR	Output	HIS RS232 data terminal ready
21	HIS_SIG_RTN	Power	HIS RS232 signal common
22	nHIS_BOOT_SEL	Input	Boot select signal: 0 = download, 1 = flash
23	HIS_ANALOG_OUT0	Output	HIS analog output #0, 0-5.00 V analog voltage level
24	HIS_ANALOG_OUT1	Output	HIS analog output #1, 0-5.00 V analog voltage level
25	HIS_ANALOG_OUT2	Output	HIS analog output #2, 0-5.00 V analog voltage level
SHLD	Chassis	Power	Cable shield

Chapter 3: Theory of Operation



MC PCBA

3.2.5 Motor Controller (MC) PCBA

- Controls the blower motor according to speed or current as commanded by ventilator software.
- Provides electrical interfaces to the DA PCBA, oxygen and air flow sensors, fan, and primary speaker.
- Includes monitoring of an embedded temperature sensor in the blower motor.
- Includes analog to digital converters (ADCs) and digital to analog converters (DACs) for flow control and monitoring.
- Includes two energy storage capacitors that increase motor power usage efficiency and power a backup audible alarm (a piezo alarm) and Alarm LED for at least two minutes.
- Includes EEPROM for calibration data, board identification information, and MC PCBA power-on hours.

3.2.6 Data Acquisition (DA) PCBA



DA PCBA

- Provides precision measuring and signal conditioning.
- Includes analog-to-digital converters (ADCs) and digital-to-analog converters (DACs) for flow and pressure monitoring signals.
- Controls the oxygen solenoid valve with 12-bit accuracy.
- Includes barometric (measurement range 525 to 850 mmHg) and oxygen pressure (measurement range 0 to 87 psig) transducers.
- Includes individual patient proximal and machine pressure transducers (measurement range -20 to +65 cmH₂O).
- Includes EEPROM for calibration data, board identification information, and DA PCBA power-on hours.
- Drives the solenoid valves mounted to the manifold.
- Interfaces to the air and oxygen flow sensors.

3.2.7 Flow Sensors

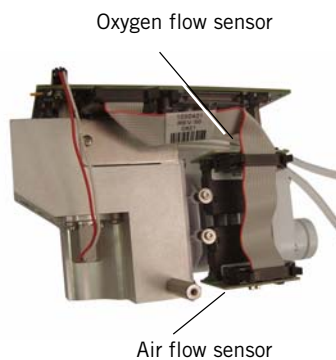

- Calibrated to the specific gas (air or oxygen).
- Provide the signal source for the oxygen and air flow signals. Convert manifold gas flow into an analog signal, which is sent to DA PCBA for filtering and conversion.
- Air flow sensor measures flows from -240 to 240 SLPM. Oxygen flow sensor measures flows from 0 to 240 SLPM.
- Includes EEPROM for calibration data, board identification information, and power-on hours for each flow sensor.

3.2.8 User Interface



User interface

- Includes indicators and controls for setting and monitoring parameters.
- Includes LCD, backlight inverter PCBA, touch screen, power switch overlay, rotary adjustment (nav-ring) assembly, UI PCBA, and switch PCBA.
- Audible alarms: Primary audio alarm includes two alarm speakers in the base unit (adjustable from 60 to 95 dBA at 1 m), one connected through the PM PCBA, and one connected through the MC PCBA. Backup audio alarm (piezo alarm) mounted on the CPU PCBA.

3.2.9 LCD Assembly



LCD assembly

- 12.1-in. diagonal flat panel, 768 x 1024 pixels with 6-bit color.
- Connects to backlight inverter PCBA and CPU PCBA through the PM PCBA.
- Cold cathode fluorescent lamp (CCFL) backlight with 10,000-hour minimum life (half initial brightness).

3.2.10 Backlight Inverter PCBA

- Backlight inverter PCBA provides adjustable backlight drive voltage.
- Backlight dimming capability using a 0 to 3.5-V control voltage from the CPU PCBA through the PM PCBA

Backlight
inverter
PCBA



Chapter 3: Theory of Operation

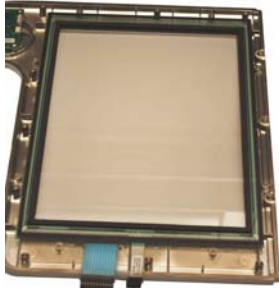

Touch screen assembly

3.2.11 Touch Screen Assembly

- Uses a robust five-wire resistive panel.
- Resolves touches in a configuration 0.3 x 0.3-in. matrix.

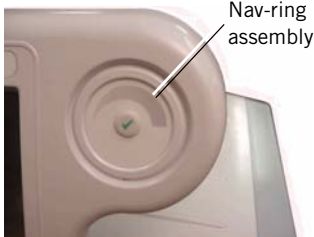

3.2.12 Nav-Ring Assembly (Rotary Adjustment)

- Rotary adjustment used to change setting values.
- Center push-button (on switch PCBA) to accept a value of a selected field.



Power switch overlay

3.2.13 Power Switch Overlay

- Includes power switch, and embedded indicators for power status, battery charge status, and alarms.



Switch PCBA

3.2.14 Switch PCBA

- Interconnection between rotary adjustment and UI PCBA and CPU PCBA.
- Provides a center push button and interface to nav-ring.
- Connects to UI PCBA.



UI PCBA

3.2.15 UI PCBA

- Provides a connection for backlight PCBA, touch panel, switches, and switch PCBA to PM PCBA.
- Mounts behind LCD, provides connectors to backlight inverter PCBA, power switch overlay, switch PCBA, and touch screen.
- Connects to PM PCBA.

Chapter 3: Theory of Operation

3.3 Electronic Signal Paths

The following table summarizes the electronic signal paths for V60 ventilator components.

Table 3-2: V60 Signal Paths

Component	Signal Path Sequence
Air flow sensor	DA PCBA, MC PCBA, CPU PCBA
Alarm indicator	Power switch overlay, UI PCBA, PM PCBA, CPU PCBA
Backlight inverter PCBA	Input: UI PCBA, PM PCBA, CPU PCBA Output: LCD CCFL
Barometric pressure	DA PCBA, MC PCBA, CPU PCBA
Battery indicator	Power switch overlay, UI PCBA, PM PCBA, CPU PCBA
Blower motor	MC PCBA
CPU PCBA DAC	CPU PCBA
DA PCBA ADC	DA PCBA, MC PCBA, CPU PCBA
DA PCBA DAC	DA PCBA, MC PCBA, CPU PCBA
Ethernet connector	CPU PCBA
Fan	MC PCBA, CPU PCBA, PM PCBA
LCD	Power: PM PCBA Signal: PM PCBA, CPU PCBA CCFL: Backlight inverter PCBA
Internal battery	PM PCBA
Speaker #1	MC PCBA, CPU PCBA
Speaker #2	PM PCBA, CPU PCBA
MC PCBA ADC	MC PCBA, CPU PCBA
MC PCBA DAC	MC PCBA, CPU PCBA
Nav-ring assembly	Switch PCBA, UI PCBA, PM PCBA, CPU PCBA
Nurse call connector	CPU PCBA
Oxygen flow sensor	DA PCBA, MC PCBA, CPU PCBA
Oxygen inlet pressure sensor	DA PCBA, MC PCBA, CPU PCBA
Oxygen solenoid valve	DA PCBA
Power indicator	Power switch overlay, UI PCBA, PM PCBA, CPU PCBA
Power supply	Input: AC inlet Output: PM PCBA
Power switch	Power switch overlay, UI PCBA, PM PCBA, CPU PCBA
Proximal pressure sensor	DA PCBA, MC PCBA, CPU PCBA
Solenoid valves	DA PCBA
Switch PCBA	UI PCBA, PM PCBA, CPU PCBA
Touch screen	UI PCBA, PM PCBA, CPU PCBA
USB device connector	CPU PCBA
USB host connector	CPU PCBA

Figure 3-2 shows a wiring diagram for the main assembly.

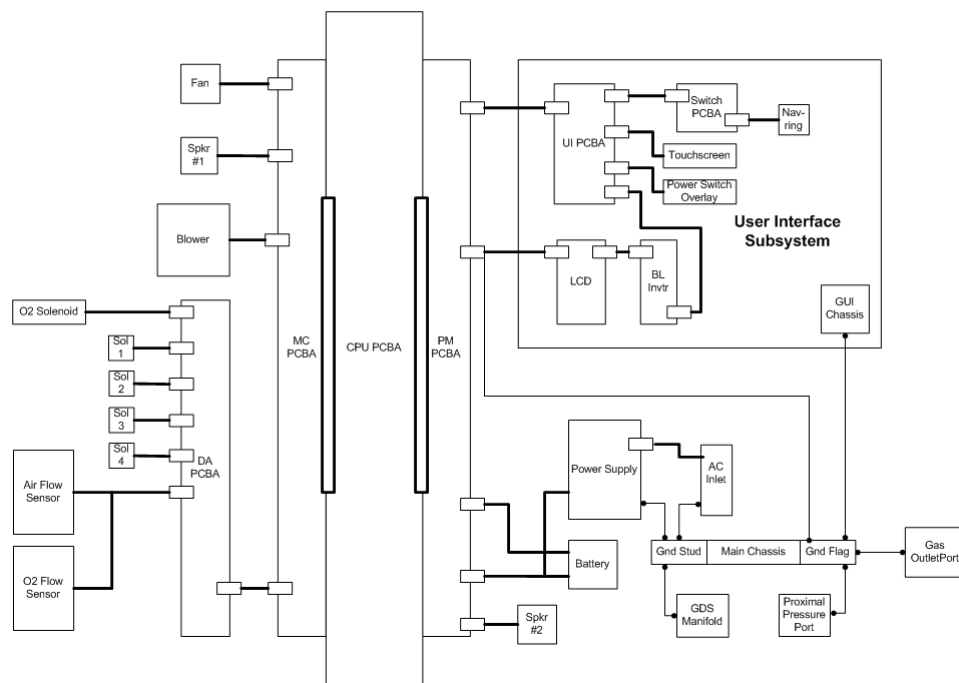

Figure 3-2: V60 Main Assembly Wiring Diagram.

Chapter 3
Theory of Operation

(This page is intentionally blank.)

Figure 3-3 shows a wiring diagram for the UI subsystem.

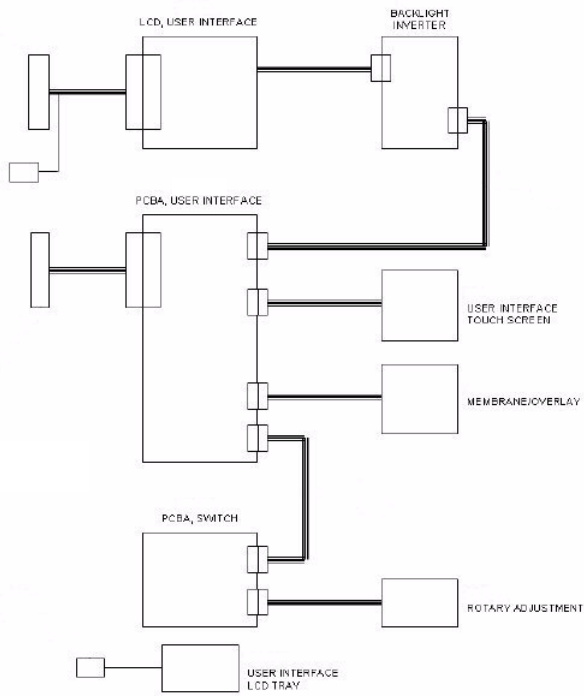

Figure 3-3: V60 UI Assembly Wiring Diagram

Chapter 3
Theory of Operation

(This page is intentionally blank.)

Figure 3-4 shows a block diagram of the power supply.

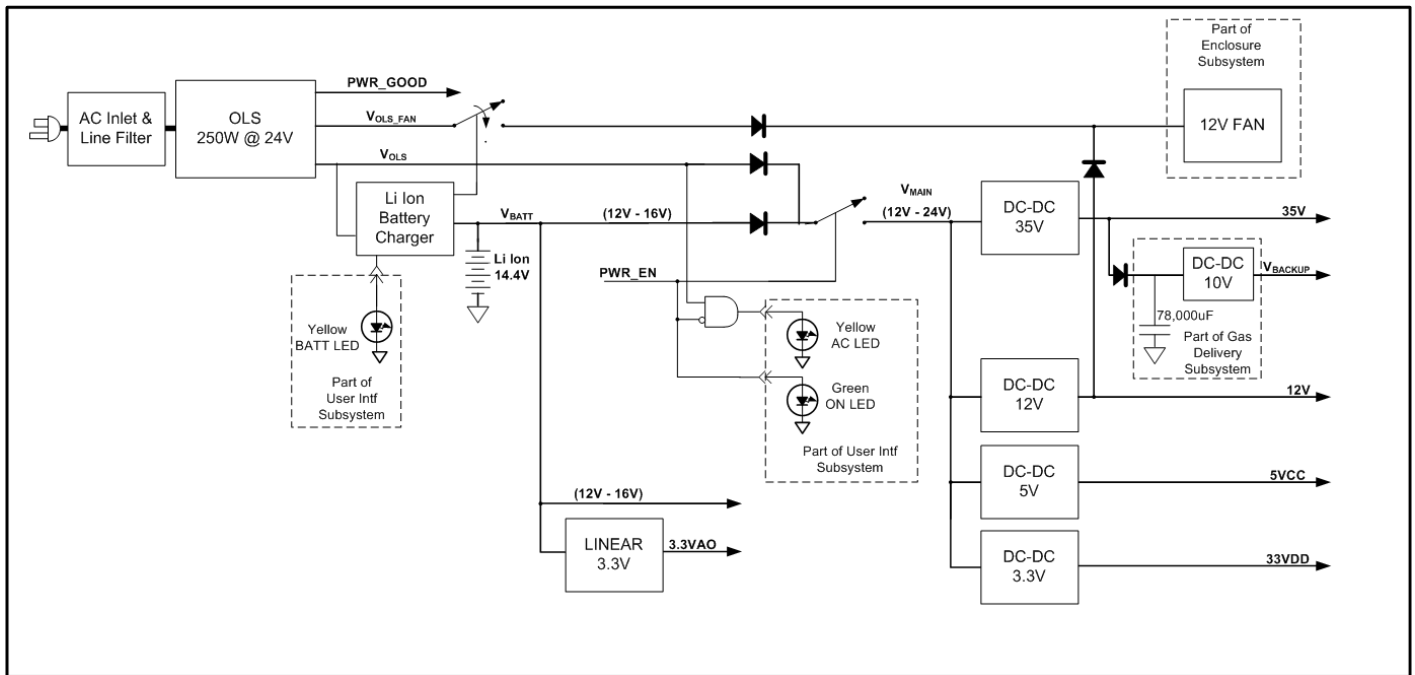

Figure 3-4: Power Supply Block Diagram

Chapter 3
Theory of Operation

(This page is intentionally blank.)

Figure 3-5 shows a block diagram of the PM PCBA.

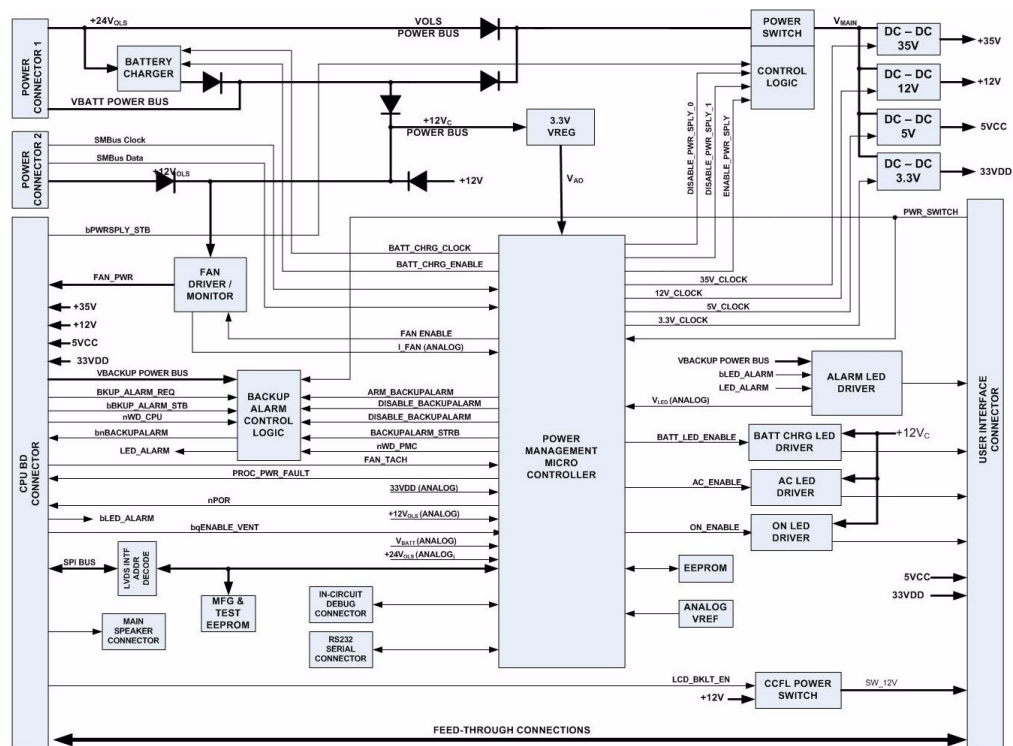

Figure 3-5: Power Management (PM) PCBA Block Diagram

(This page is intentionally blank.)

Figure 3-6 shows a block diagram of the MC PCBA.

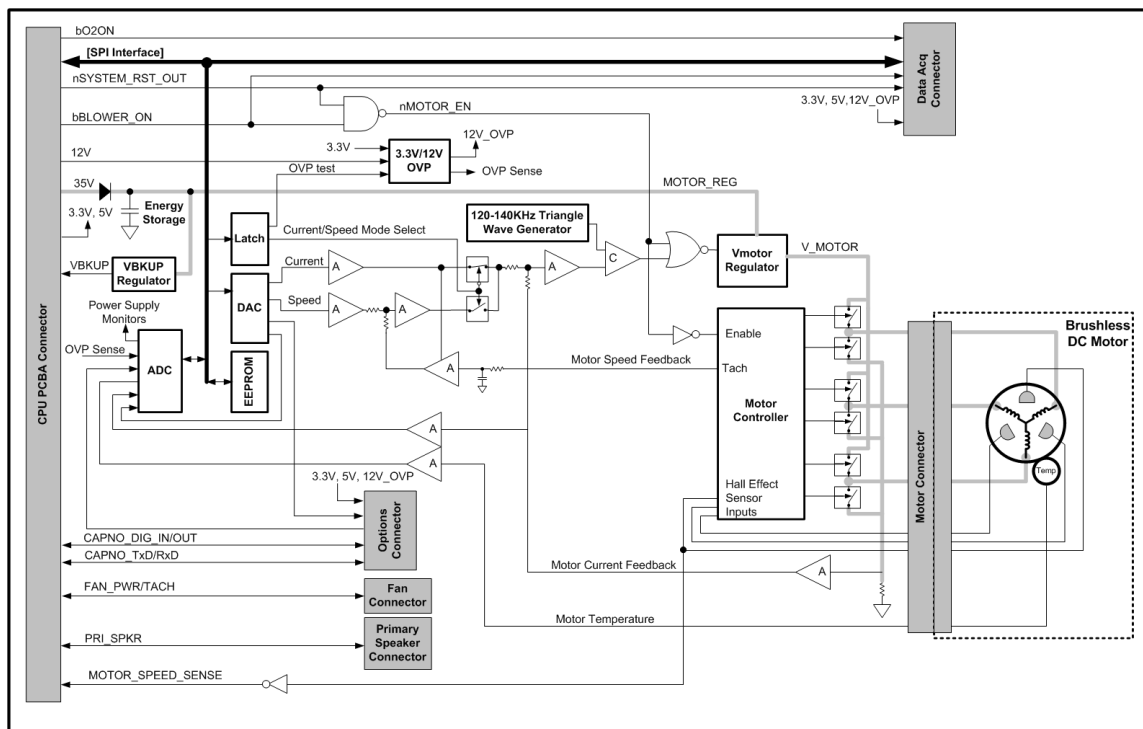

Figure 3-6: Motor Controller (MC) PCBA Block Diagram

Chapter 3
Theory of Operation

(This page is intentionally blank.)

Chapter 4. Periodic Maintenance

Perform cleaning, sterilizing, and periodic maintenance procedures (Table 4-1) to ensure consistent ventilator operation. Hospital personnel can perform all maintenance tasks except the annual preventive maintenance procedures (the preventive maintenance procedures must be performed by a qualified service technician). The *V60 Ventilator User Manual* summarizes periodic care and maintenance procedures.

Table 4-1: Periodic Maintenance Procedures

Frequency	Component	Maintenance
Daily	Patient outlet bacteria filter	<ul style="list-style-type: none"> Check for occlusions, cracks, and tears.
Monthly	Cooling fan filter	Inspect for occlusions, dust lint, etc. If discolored or dirty, replace or remove and wash or rinse thoroughly and let dry completely before reinstalling.
250 hours	Air inlet filter	Inspect and replace as required (environments with more lint and dust may require more frequent replacement).
Annually	Reusable bacteria filters	Replace and destroy reusable filters.
	<ul style="list-style-type: none"> Air inlet filter Cooling fan filter 	<ul style="list-style-type: none"> Install annual preventive maintenance kit (P/N 1054378). Kit contents are subject to change. Clean ventilator interior and exterior. Inspect the oxygen inlet filter. Complete performance verification procedure.
CAUTION: Only qualified service technicians are to install preventive maintenance kits or perform service procedures.		

4.1 Annual Preventive Maintenance Instructions

Follow these steps to perform the annual preventive maintenance (PM) procedure on the V60 ventilator.

NOTE: The annual PM procedure must be performed by a qualified service technician in an appropriate setting, such as a biomedical repair facility. Use a clean patient circuit and filters when performing any testing or operational checkout.

1. Clean the exterior of the V60 ventilator using universal precautions (including mask, gloves, eye protection).
2. Enter Diagnostic mode by pressing and holding the nav-ring **Enter** button and turn on the ventilator by pressing the **On/Shutdown** button on the user interface. Within 5 seconds, press the nav-ring **Enter** button again to enter Diagnostic mode. The Diagnostics Menu appears (Figure 4-1).

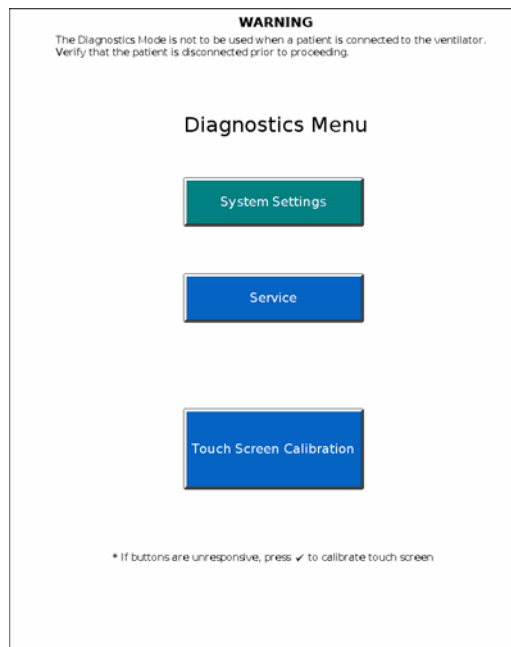

Figure 4-1: Diagnostics Menu

3. Touch **Service** to display the V60 Ventilator Information screen (Figure 4-2).

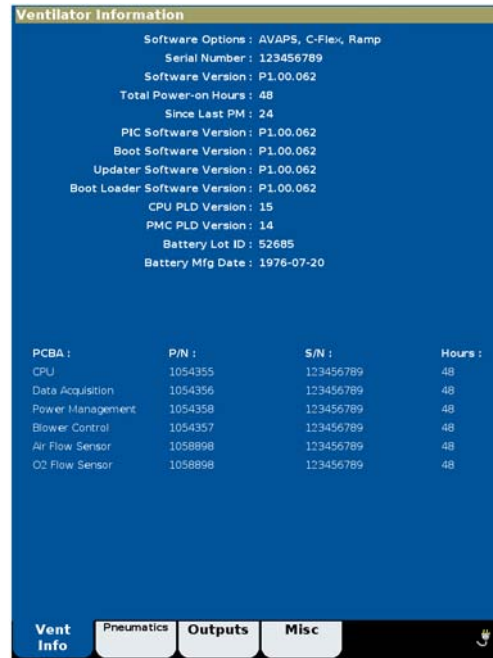

Figure 4-2: Ventilator Information Screen

4. Record the following information on the Performance Verification Data Form (Chapter 8):
 - Software options
 - Ventilator serial number
 - Software version
 - Total power-on hours
 - Hours since last PM
 - Battery lot number
 - Battery manufacture date
5. Generate a diagnostic report (DRPTA) for the ventilator (Chapter 6).
6. Turn off the V60 by pressing the **ON/Shutdown** button.
7. Disconnect all power, remove the top cover, and remove the EMI shroud from the power supply (section 7.16).
8. Use an electrostatic discharge (ESD) safe vacuum to remove any accumulated dust and debris from the inside the ventilator enclosure.
9. Inspect all electrical and pneumatic connections.

10. Replace the air inlet filter (section 7.2).
11. Remove the oxygen filter cap from the GDS (section 7.20). Inspect the oxygen inlet filter for contamination or debris and verify that it is properly installed.
12. From outside the bottom enclosure, remove the filter retainer and replace the cooling fan filter (Figure 4-3).

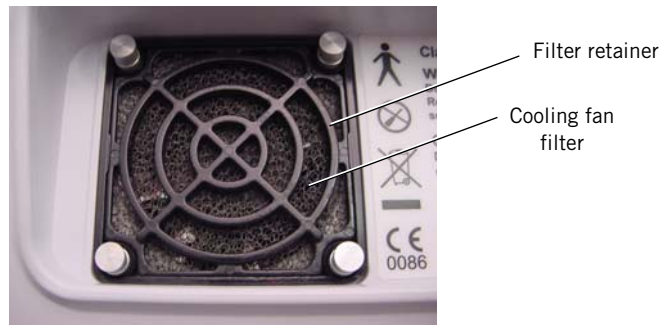

Figure 4-3: Cooling Fan Filter Retainer

13. Reassemble the V60 ventilator and complete the Performance Verification (Chapter 8).
14. If the ventilator is not already in diagnostic mode, press and hold the nav-ring **Enter** button and turn on the ventilator by pressing the **On/Shutdown** button on the user interface. Within 5 seconds, release and press the nav-ring **Enter** button again to enter Diagnostic mode.
15. Turn on the PC and connect a standard 9-pin male/female RS-232 null modem cable and a 9-pin to 25-pin female/male adapter between the PC serial port and the V60 ventilator.
16. Click on the HyperTerminal or Tera Term icon to enable communication with the V60 ventilator.

17. Type:

#RESETPM

(all caps) in the dialog box, and press **Enter** to reset hours since last PM to zero (Figure 4-4).

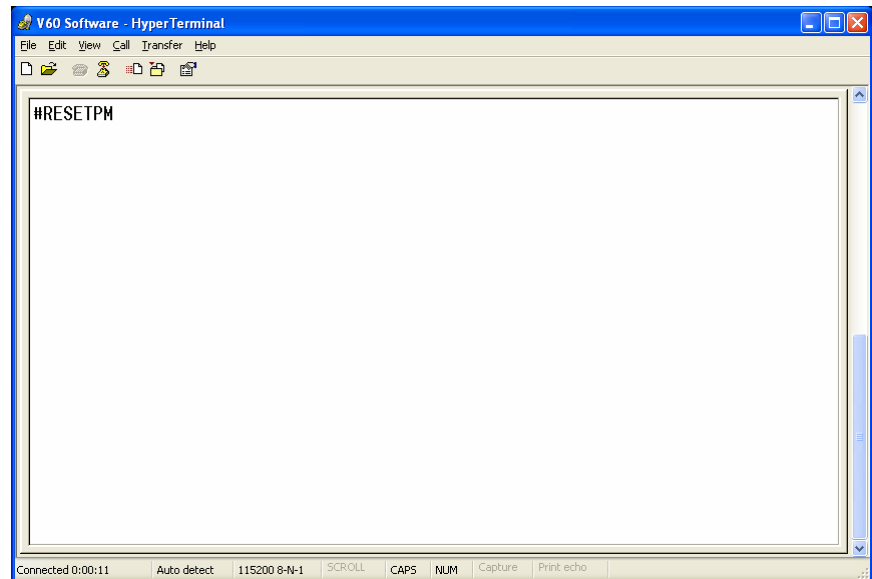

Figure 4-4: Reset Hours since Last PM Command (HyperTerminal)

18. When the hours since last PM have been successfully reset, the dialog box displays:

?RESETPMOK

19. Type

#CLRLOG

(all caps) in the dialog box, and press **Enter** to clear the diagnostic log (Figure 4-5).

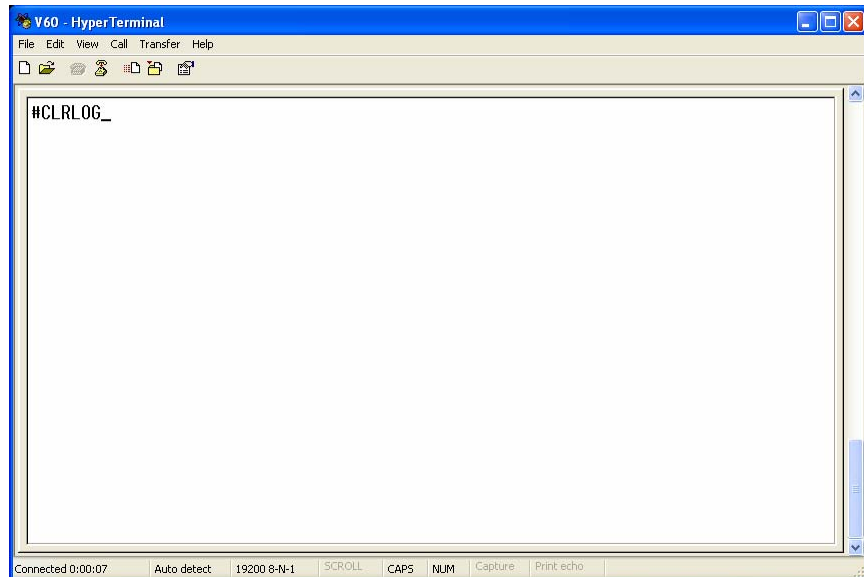

Figure 4-5: Clear Diagnostic Codes Command (HyperTerminal)

20. When the diagnostic log has been successfully cleared, the dialog box displays:

?CLRLOGOK

21. Touch **System Settings**, and then touch **Restore Default Settings**.

22. Touch **Date/Time** and correct the date and time if necessary.

23. Turn the V60 ventilator off by pressing the **ON/Shutdown** button.

24. Upon successful completion of the performance verification, hours reset, and restoring the default settings, enter the required information on the PM and electrical safety labels.

Affix the labels to the V60 ventilator (Figure 4-6).



Figure 4-6: Electrical Safety and PM Label Placement

25. Apply the clear chemical-resistant label over the PM label.
26. The annual PM is complete.

(This page is intentionally blank.)

Chapter 5. Diagnostic Mode and Troubleshooting

Use diagnostic mode to perform these functions:

- *System settings*: language, ventilator date and time, pressure units, restore default settings, enable software options, and Baud rate.
- *Service*: ventilator information, pneumatics and outputs screens (for troubleshooting), and miscellaneous features (viewing the significant event log, downloading software, touch screen diagnostics, high pressure leak test, and system leak test).
- *Touch screen calibration*.

This chapter also provides detailed information on diagnostic codes and troubleshooting (section 5.4).

WARNING: Do not enter diagnostic mode while a patient is connected to the ventilator.

NOTE: This mode is primarily reserved for use by a qualified service technician.

To enter diagnostic mode:

1. Press and hold the nav-ring **Enter** button then press and release the ventilator **On/Shutdown** button on the user interface.
2. Within five seconds, press the nav-ring **Enter** button again to enter the Diagnostics Menu (Figure 5-1).

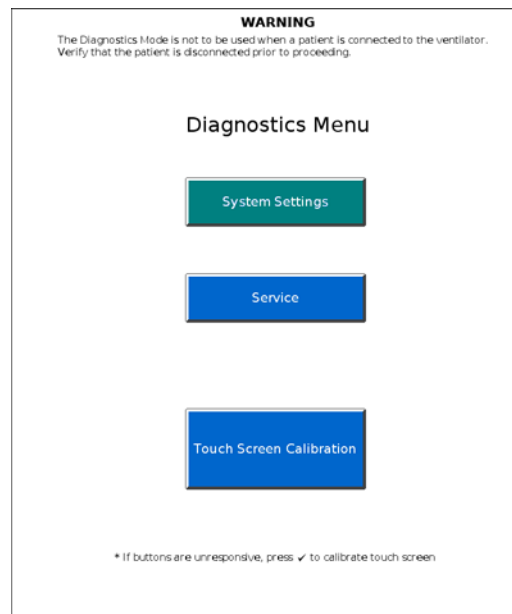

Figure 5-1: Diagnostics Menu

3. To exit diagnostic mode at any time, press the **ON/Shutdown** button.

5.1 System Settings

The System Settings button allows access to these functions (Figure 5-2):

- Language (language button is a different color)
- Date/Time
- Pressure Units
- Restore Default Settings
- Software Options
- Baud Rate

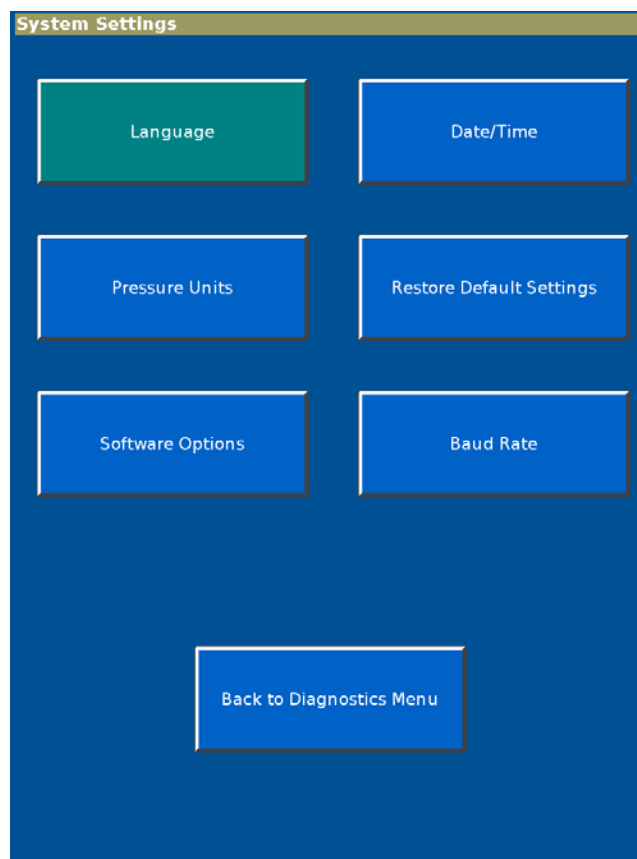

Figure 5-2: Diagnostic Mode: System Settings

5.1.1 Selecting a Language

The Set Language screen allows you to select the language displayed during ventilation mode.

NOTE: Screens displayed after touching the **Service** button from the Diagnostics Menu appear in English, regardless of the selected language.

1. From the System Settings screen, touch **Language**.
2. Touch the language button on the Set Language screen (Figure 5-3).

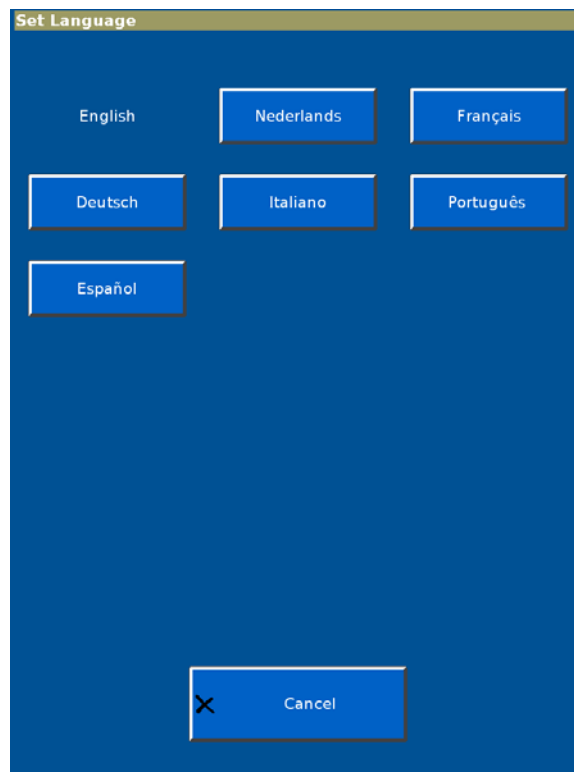

Figure 5-3: Set Language Screen

3. The screen shows the selected language (Figure 5-4).
4. To apply the new language, touch **Ventilator Shutdown**. To exit without changing the language, touch **Cancel**.

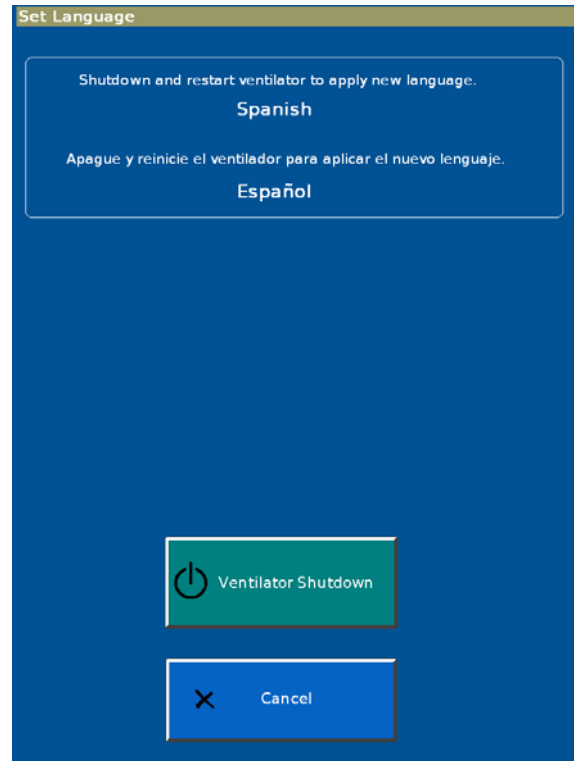

Figure 5-4: Set Language - Apply or Cancel

5.1.2 Setting Date and Time

The Set Date and Time screen allows you to update the ventilator's date and time. The ventilator uses these settings for the significant event log, and does *not* adjust settings for daylight savings.

1. From the System Settings screen, touch **Date/Time**.
2. Enter the date and time, then touch **Accept** (Figure 5-5).
To exit without changing the date and time, touch **Cancel**.



Figure 5-5: Set Date and Time Screen

5.1.3 Restoring Default Settings

The Restore Default Settings screen allows you to restore ventilation and alarm settings to their default values. This function does *not* change other settings such as brightness, loudness, language, Baud rate, or pressure units.

1. From the System Settings screen, touch **Restore Default Settings**.
2. Touch **Restore Defaults** on the Restore Default Settings screen (Figure 5-6).
To exit without restoring default settings, touch **Cancel**.

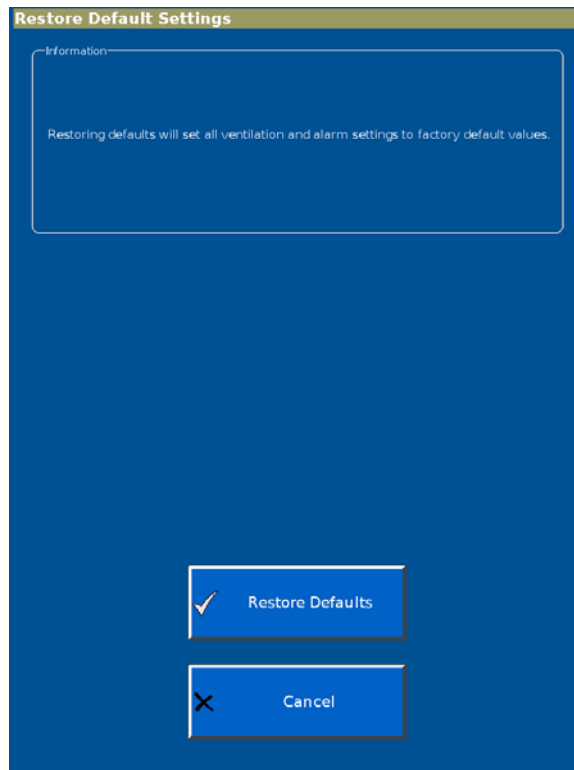

Figure 5-6: Restore Default Settings Screen

3. When all ventilator and alarm settings have been restored to factory default values, the screen displays this message:

Ventilation and Alarm Settings have been restored to factory defaults.

5.1.4 Selecting Pressure Units

The Set Pressure Units screen allows you to select what unit of pressure the ventilator displays during ventilation and Diagnostic modes.

1. From the System Settings screen, touch **Pressure Units**.
2. Touch the selected pressure unit button on the Set Pressure Units screen (Figure 5-7).

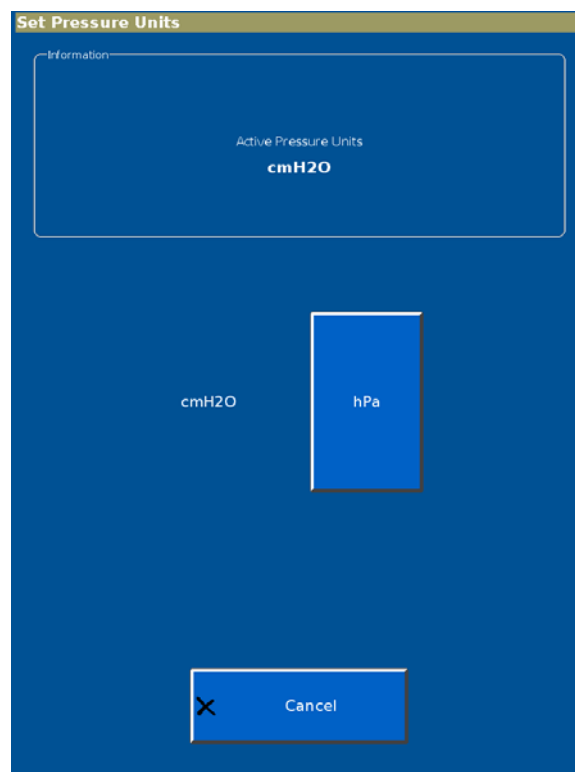

Figure 5-7: Set Pressure Units Screen

3. The screen displays the selected pressure unit and this message:
Pressure units will apply after a ventilator shutdown and restart.
4. To apply the new unit of pressure, touch **Ventilator Shutdown**.
To exit without changing the unit of pressure, touch **Cancel**.

5.1.5 Enabling Software Options

Every software option has a unique enable code for each ventilator. A unique option code is required for each software option before it can be enabled.

NOTE: *Do not* install an option until you have verified that the ventilator serial number on the enclosure matches the serial number shown on the Ventilator Information screen (section 5.2.1). If a serial number must be reprogrammed, do so *before* enabling an option.

1. From the System Settings screen, touch **Software Options**.
2. Use the onscreen keypad on the Enable Software Options screen (Figure 5-8) to enter the option code, then touch **Accept**.

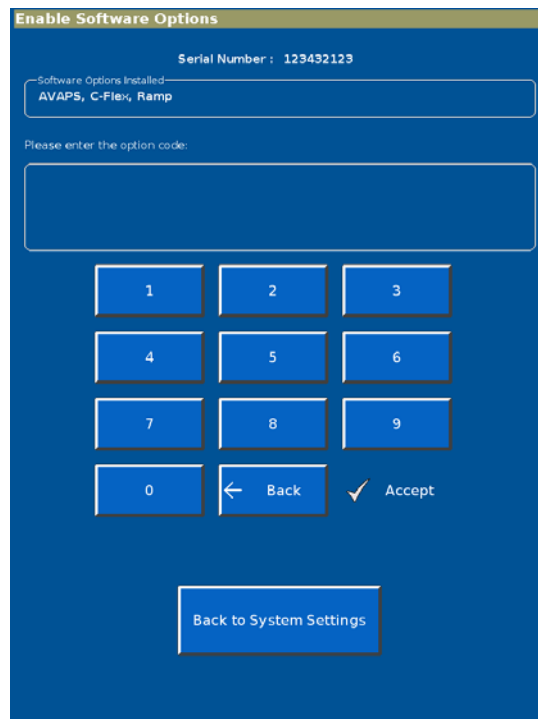

Figure 5-8: Enable Software Options Screen

3. If the option code is invalid, the screen prompts you to reenter.
4. When the software option has been successfully enabled, the screen displays *Enabled:* followed by the option name.
5. Repeat as needed to enable additional options.
6. To exit the Enable Software Options screen at any time, touch **Back to System Settings**.

5.1.6 Baud Rate

The Set Baud Rate screen allows you to change the ventilator Baud rate for serial communications during ventilation mode. Diagnostic mode always uses 19,200 Baud.

1. From the System Settings screen, touch **Baud Rate**.
2. Touch the button to select the Baud rate (Figure 5-9).

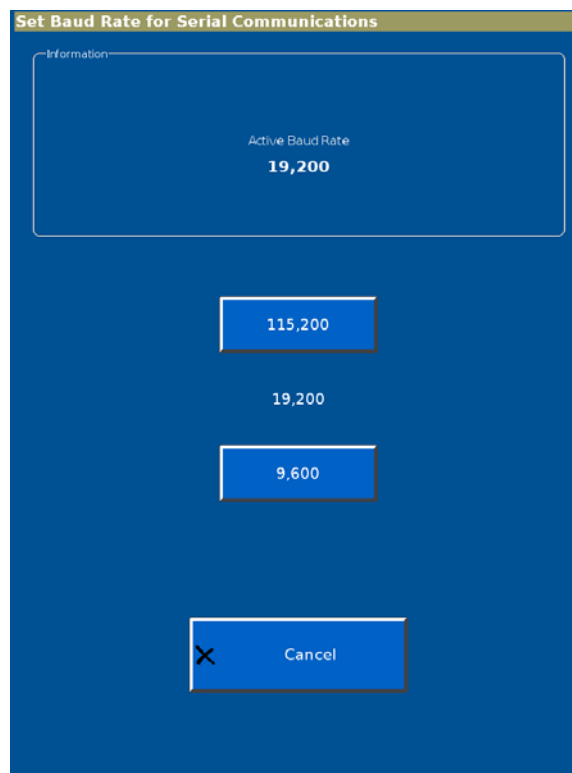

Figure 5-9: Set Baud Rate Screen

3. The screen then displays this message:

Baud rate is now set to:

followed by the selected Baud rate.

5.2 Service

The Service button allows access to these functions:

- Ventilator information
- Pneumatic controls
- Output controls
- Miscellaneous (significant event log, download mode, and touch screen diagnostics, high pressure leak test, and system leak test).

NOTE: Service button functions are intended for use by qualified service technicians.

5.2.1 Viewing Ventilator Information

Ventilator information is used for periodic maintenance and troubleshooting.

1. From the Service screen, touch the **Vent Info** tab.
2. The Ventilator Information screen displays software options, serial numbers, software versions, power-on hours, hours since last PM, and information on the internal battery and PCBAs (Figure 5-10).

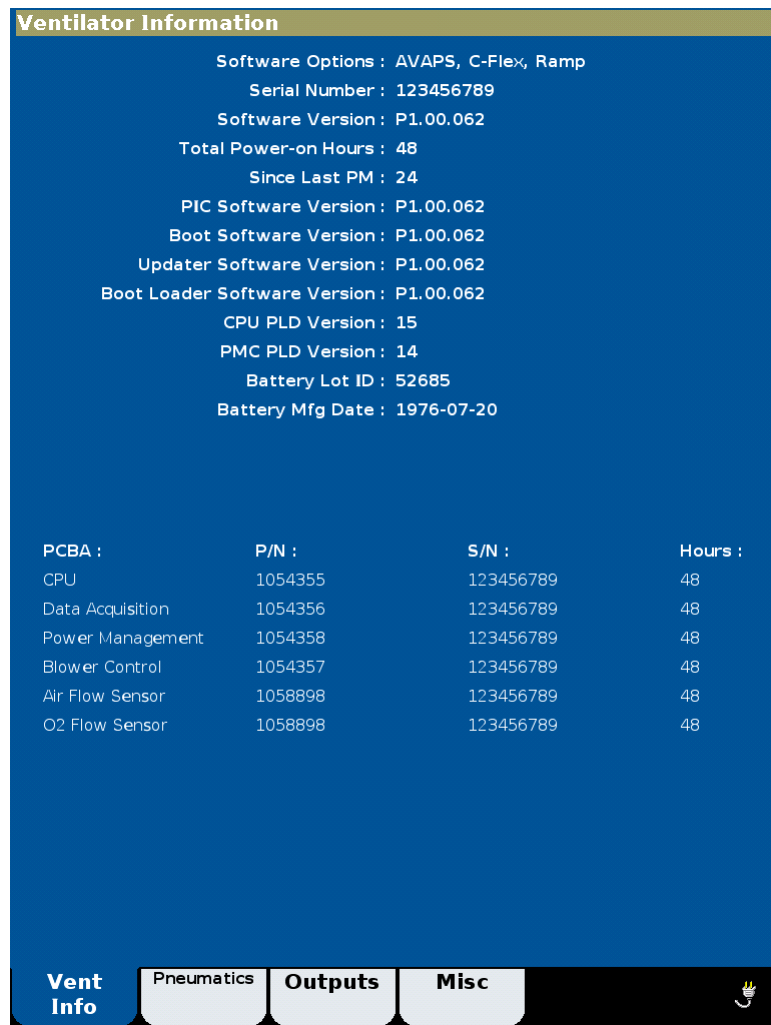

Figure 5-10: Ventilator Information Screen

Diagnostic Mode and Troubleshooting

5.2.2 Pneumatic Controls

This Pneumatic Controls screen allows you to adjust flows, pressures, oxygen concentrations, and the state of each solenoid.

1. From the Service screen, touch the **Pneumatics** tab.
2. The screen displays real-time diagnostic information and pneumatic controls (Figure 5-11).



Figure 5-11: Pneumatic Controls Screen

5.2.3 Output Controls

This Output Controls screen allows you to set and verify wrap, analog, and digital outputs.

NOTE: When entering wrap counts, ensure that the displayed values are within ± 23 counts of the set value.

1. From the Service screen, touch the **Outputs** tab.
2. The screen shows diagnostic information and output controls (Figure 5-12).

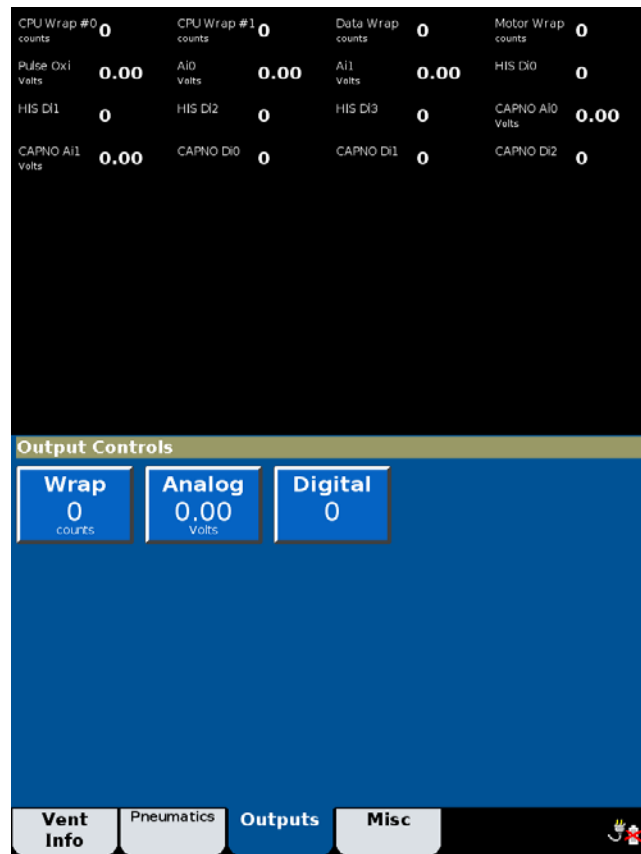

Figure 5-12: Output Controls Screen

5.2.4 Miscellaneous

The Miscellaneous screen allows you to access the significant event log, touch screen diagnostics, download mode, high pressure leak test, and system leak test.

1. From the Service screen, touch the **Misc** tab.
2. The screen includes the **Significant Event Log**, **Download Mode**, **Touch Screen Diagnostics**, **High Pressure Leak Test**, and **System Leak Test** buttons (Figure 5-13).

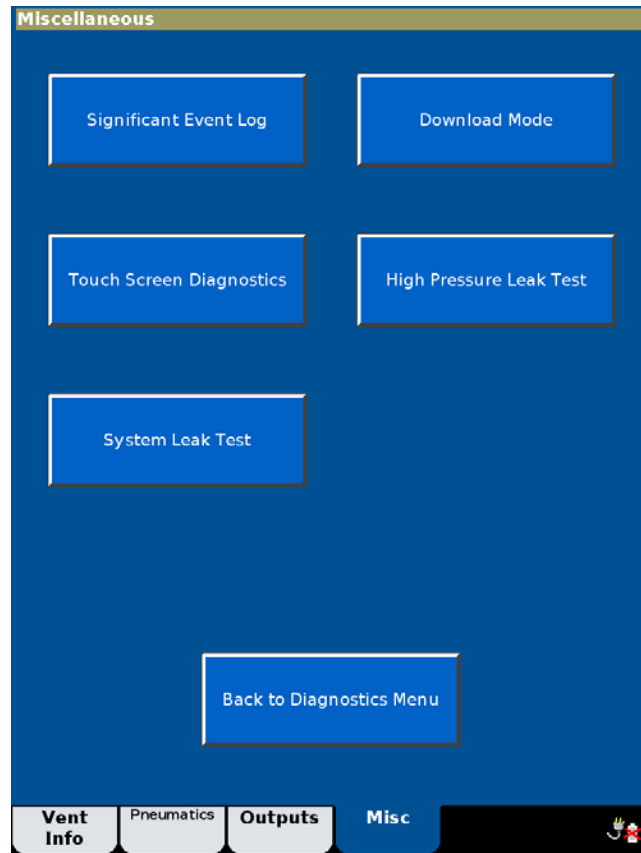

Figure 5-13: Miscellaneous Screen

3. To exit the Miscellaneous screen at any time, touch **Back to Diagnostics Menu**.

Significant Event Log

The significant even log allows you to view a log of setting changes, alarms, and diagnostic codes.

1. From the Miscellaneous screen, touch **Significant Event Log**.
2. You can use the arrow buttons to page through the significant event log (Figure 5-14) 25 entries at a time.



Figure 5-14: Significant Event Log

3. To display the beginning or end of the significant event log, touch the **To Newest** or **To Oldest** button.

Refer to *Chapter 6, Reports and Software Downloads* for information on interpreting the significant event log and saving it to a computer.

Diagnostic Mode and Troubleshooting

Download Mode

The Download Mode screen allows you to load operational software onto the CPU PCBA.

1. From the Miscellaneous screen, touch **Download Mode** to prepare the ventilator for a software download. Refer to *Chapter 6, Reports and Software Downloads* for more information on downloading software.
2. When the software download is complete, the download complete screen appears (Figure 5-15).

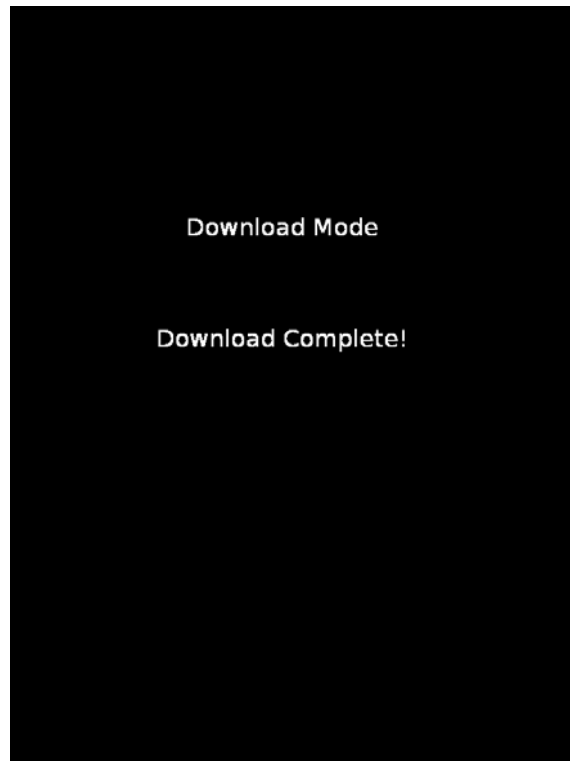

Figure 5-15: Download Complete Screen

Touch Screen Diagnostics

The Touch Screen Diagnostics screen allows you to verify touch screen x and y coordinates.

1. From the Miscellaneous screen, touch **Touch Screen Diagnostics**.
2. At the touch screen diagnostics screen (Figure 5-15), touch the screen in multiple places to verify correct touch screen function.

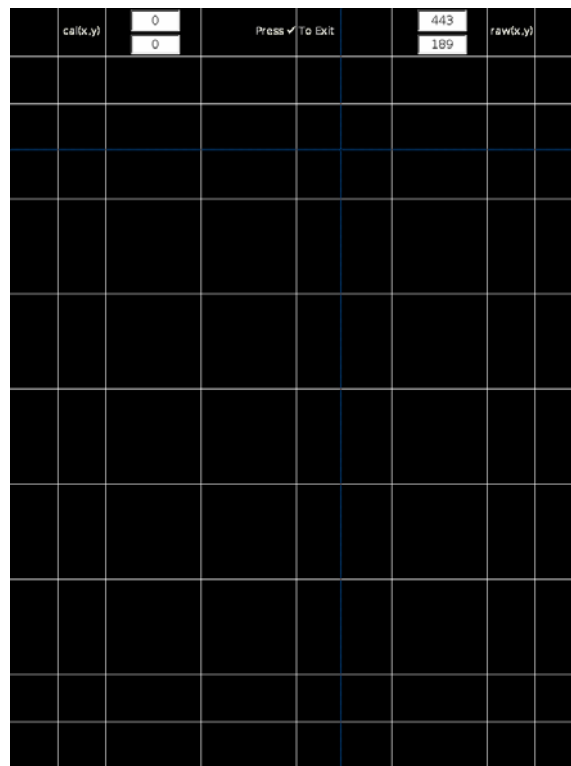

Figure 5-16: Touch Screen Diagnostics Screen

5.3 Touch Screen Calibration

The Touch Screen Calibration button allows you to calibrate the touch screen x and y coordinates (Figure 5-17):

1. From the Diagnostics Menu, touch **Touch Screen Calibration**.

NOTE: If the **Touch Screen Calibration** button does not respond, press the navigating **Enter** button to begin.

2. Follow the onscreen instructions to perform the calibration. Touch the middle of each target with a blunt, narrow object.

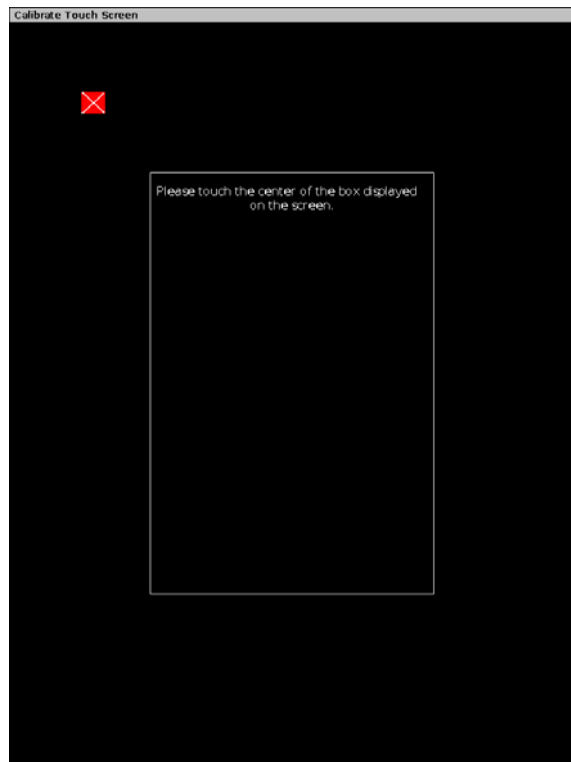

Figure 5-17: Calibrate Touch Screen

5.4 Diagnostic Codes, Alarms, and Troubleshooting

This section lists possible ventilator diagnostic codes (codes generated by the ventilator when an event such as a setting change or fault condition is detected, or when an alarm indicates patient or ventilator conditions), and the recommended repair for each. Follow the repair procedures in order until the problem is resolved.

NOTE: See Chapter 7 for information on removing and replacing ventilator components. See Chapter 8 for performance verification procedures.

Table 5-1: Diagnostic Codes and Troubleshooting

Diagnostic code	Description	Recommended repair
1000-10FF Vent Inop Diagnostic Codes		
(High-priority error conditions that preclude continued safe operation of the ventilator. A Vent Inop alarm displays on the screen, turns on remote alarm interfaces, and disables oxygen flow and blower operation. Immediately place the patient on another means of ventilatory support.) CBIT = continuous built-in tests. POST = power on self test.		
1000 (CBIT)	3.3 V supply failed.	1. Replace PM PCBA.
1001 (CBIT)	12 V supply failed.	1. Replace PM PCBA.
1002 (CBIT)	Blower temperature too high.	1. Verify that cooling fan is operational 2. Replace blower. 3. Replace MC PCBA.
1003 (CBIT)	Internal temperature high at CPU PCBA.	1. Replace CPU PCBA.
1004 (CBIT)	Internal temperature high at DA PCBA.	1. Verify that cooling fan is operational. 2. Replace DA PCBA.
1005 (CBIT)	Internal temperature high at MC PCBA.	1. Verify that cooling fan is operational. 2. Replace MC PCBA.
1006 (CBIT)	DA PCBA ADC failed.	1. Replace DA PCBA.
1007 (POST)	Machine and proximal pressure sensors failed.	1. Replace DA PCBA to MC PCBA cable. 2. Replace DA PCBA.
1008 (CBIT)		

Diagnostic Mode and Troubleshooting

Table 5-1: Diagnostic Codes and Troubleshooting

Diagnostic code	Description	Recommended repair
1009	Pressure regulation high.	1. Verify pressures and flows. 2. Replace DA PCBA. 3. Replace MC PCBA.
100A (CBIT)	DA PCBA ADC reference failed.	1. Verify 3.3V in diagnostics. 2. Verify 2.5V ref on DA PCBA. 3. Replace DA PCBA to MC PCBA cable. 4. Replace DA PCBA. 5. Replace PM PCBA.
100B (POST)	Watchdog test failed.	Replace CPU.
1100-11FF Check Vent Diagnostic Codes		
(High-priority error conditions that require immediate attention. Ventilator continues to operate with limited performance. Do not use the ventilator until the problem is corrected.) CBIT = continuous built-in tests. POST = power on self test.		
1100 (CBIT)	Program CRC test failed.	1. Re-load software. 2. Replace CPU PCBA.
1101	Ventilator restarted.	1. Replace CPU PCBA.
1102 (POST)	Primary alarm failed.	1. Listen for audible sound from speakers. 2. Verify speakers are connected. 3. Replace speaker #1 (MC PCBA). 4. Replace speaker #2 (PM PCBA). 5. Replace CPU PCBA.
1104 (POST)	Backup alarm failed.	1. Replace PM PCBA. 2. Replace CPU PCBA.
1105 (POST)	Alarm LED failed.	1. Replace power switch overlay. 2. Replace UI to PM PCBA cable. 3. Replace PM PCBA (PM PCBA only if LED is functioning).
1106 (POST)	Machine pressure sensor calibration data error. Proximal pressure is not measured. Pressure-related alarms are compromised.	1. Replace DA PCBA.

Diagnostic Mode and Troubleshooting

Table 5-1: Diagnostic Codes and Troubleshooting

Diagnostic code	Description	Recommended repair
1107 (POST)	Proximal pressure sensor calibration data error. Proximal pressure is not measured. Pressure-related alarms are compromised.	1. Replace DA PCBA.
1108 (POST) 1109 (CBIT)	Machine pressure sensor auto-zero failed. Proximal pressure is not measured. Pressure-related alarms are compromised.	1. Verify pin alignment between solenoids and DA PCBA. 2. Replace machine auto-zero solenoid (SOL 2). 3. Replace DA PCBA.
110A (POST) 110B (CBIT)	Proximal pressure sensor auto-zero failed. Proximal pressure is not measured. Pressure-related alarms are compromised.	1. Verify pin alignment between solenoids and DA PCBA. 2. Replace proximal auto-zero solenoid (SOL 3). 3. Replace DA PCBA.
110C (CBIT)	Machine pressure sensor range error. Proximal pressure is not measured. Pressure-related alarms are compromised.	1. Cycle ventilator power to reset proximal pressure sensor. 2. Replace DA PCBA.
110D (CBIT)	Proximal pressure sensor range error. Proximal pressure is not measured. Pressure-related alarms are compromised.	1. Cycle ventilator power to reset proximal pressure sensor. 2. Replace DA PCBA.
110E (POST)	Air flow sensor calibration data error. Flow-related patient data is disabled. Oxygen concentration switches to 21% (air only). Default volume used in AVAPS mode. Standby disabled. Volume, leak, disconnect, and occlusion alarms compromised.	1. Replace flow sensor cable. 2. Replace flow sensor assembly. 3. Replace DA PCBA.
110F (POST)	Oxygen flow sensor calibration data error. Ventilation continues with air only.	1. Replace flow sensor cable. 2. Replace flow sensor assembly. 3. Replace DA PCBA.
1110 (POST)	Oxygen pressure sensor calibration data error. Ventilation continues with air only.	1. Replace DA PCBA.

Diagnostic Mode and Troubleshooting*Table 5-1: Diagnostic Codes and Troubleshooting*

Diagnostic code	Description	Recommended repair
1111 (CBIT)	Oxygen device failed. Ventilation continues with air only.	1. Inspect the oxygen inlet filter for contamination or debris. 2. Perform high pressure leak test (Chapter 8). 3. Verify oxygen flows (Chapter 8). 4. Replace oxygen valve. 5. Replace DA PCBA.
1112 (CBIT)	Oxygen pressure sensor range error. Ventilation continues with air only.	1. Verify correct oxygen pressure sensor function. 2. Replace DA PCBA.
1113 (POST)	Barometer calibration data error. Default barometric pressure of 686.0 mmHg (approximately 900 m/2953 ft above sea level) used in calculations.	1. Replace DA PCBA.
1114	Barometer sensor range error. Default barometric pressure of 686.0 mmHg (approximately 900 m/2953 ft above sea level) used in calculations.	1. Verify correct barometric pressure sensor function. 2. Replace DA PCBA.
1115	Auxiliary alarm supply failed. Audible and visual alarm indicators activate and the ventilator continues to ventilate with air only in a reduced capacity.	1. Replace MC PCBA. 2. Replace PM PCBA.
1116 (CBIT)	1.8 V supply failed.	1. Replace CPU PCBA.
1117 (CBIT)	3.3 V supply failed.	1. Replace PM PCBA.
1118 (POST)	5 V supply failed.	2. Replace PM PCBA.
1119 (CBIT)	12 V supply failed.	1. Replace PM PCBA.
111A (POST)	24 V supply failed.	1. Replace power supply.
111B (POST)	35 V supply failed.	1. Replace PM PCBA. 2. Replace MC PCBA.

Diagnostic Mode and Troubleshooting

Table 5-1: Diagnostic Codes and Troubleshooting

Diagnostic code	Description	Recommended repair
111C (CBIT)	DA PCBA ADC failed.	1. Replace DA PCBA.
111D (CBIT)	MC PCBA ADC failed.	1. Replace MC PCBA.
111E (CBIT)	CPU PCBA ADC failed.	1. Replace CPU PCBA.
111F (CBIT)	Internal temperature high at CPU PCBA.	1. Replace CPU PCBA.
1120 (CBIT)	Internal temperature high at DA PCBA.	1. Verify that cooling fan is operational. 2. Replace DA PCBA.
1121 (CBIT)	Internal temperature high at MC PCBA.	1. Verify that cooling fan is operational. 2. Replace MC PCBA.
1122 (CBIT)	Blower temperature high.	1. Verify that cooling fan is operational. 2. Replace blower. 3. Replace MC PCBA.
1123 (CBIT)	Battery temperature high.	1. Replace internal battery. 2. Replace PM PCBA.
1124 (CBIT)	Battery failed. Audible and visual alarm indicators activate and the ventilator continues to ventilate. Battery charger turns off.	1. Replace internal battery. 2. Replace PM PCBA.
1125 (CBIT)	Cooling fan speed error. Ventilator overheating possible.	1. Verify that cooling fan RPM is 4000 ± 1000 RPM. 2. Replace fan. 3. Replace PM PCBA.
1126	Flash file system error.	1. Repeat software download. 2. Replace CPU PCBA.
1127	OVP circuit failed.	1. Replace MC PCBA.

Diagnostic Mode and Troubleshooting

Table 5-1: Diagnostic Codes and Troubleshooting

Diagnostic code	Description	Recommended repair
1200-120F Alarm Message Diagnostic Codes		
(Alarm conditions that indicate a patient or ventilator condition that requires immediate attention.)		
1200	<p>Alarm message: <i>Patient Disconnect</i></p> <p>Patient is no longer connected to the ventilator, either through circuit, mask, or ET tube; or the patient circuit is disconnected from the ventilator and the patient is no longer receiving ventilatory support. Ventilation continues.</p>	Check patient. Confirm that ventilator and alarm settings are appropriate. If problem persists, provide alternative ventilation. Service ventilator.
1201	<p>Alarm message: <i>Patient Circuit Occluded</i></p> <p>Patient circuit occluded.</p>	Check patient. Check patient circuit for bulk liquid, crimps, or blocked filter. Confirm that ventilator and alarm settings are appropriate. If problem persists, provide alternative ventilation. Service ventilator.
1202	<p>Alarm message: <i>Proximal Pressure Line Disconnect</i></p> <p>Proximal pressure line is disconnected. Air flow to patient continues.</p>	Check patient. Reconnect proximal pressure line. Confirm that ventilator and alarm settings are appropriate. If problem persists, provide alternative ventilation. Service ventilator.
1203	<p>Alarm message: <i>Low Leak-CO₂ Rebreathing Risk</i></p> <p>Exhalation port may be occluded. Ventilation continues if possible.</p>	Check patient, as possibility of CO ₂ rebreathing could pose a potential problem. Check the port for occlusions.
1204	<p>Alarm message: <i>Low Internal Battery</i></p> <p>Battery can provide operating power for only an additional 15 minutes under nominal conditions. Autoresets when ventilator is connected to AC power.</p>	Connect the ventilator to AC power. Provide alternate ventilation.
1205	<p>Alarm message: <i>Pressure Regulation High</i></p> <p>Pressures exceed ventilator-defined thresholds. Ventilation continues. Autoresets when alarm condition removed. Transitions to the ventilator inoperative state if pressure continues to rise.</p>	Check patient. Confirm that ventilator and alarm settings are appropriate. If problem persists, provide alternative ventilation. Service ventilator.

Diagnostic Mode and Troubleshooting

Table 5-1: Diagnostic Codes and Troubleshooting

Diagnostic code	Description	Recommended repair
1206	Alarm message: <i>High Inspiratory Pressure</i> Measured inspiratory pressure is greater than the HIP setting and the ventilator cycles into exhalation. Autoresets after a complete inspiration without the alarm condition.	Check patient. Confirm that ventilator and alarm settings are appropriate. If problem persists, provide alternative ventilation. Service ventilator.
1207	Alarm message: <i>Low Inspiratory Pressure</i> Measured inspiratory pressure is less than the LIP setting.	Check patient. Confirm that ventilator and alarm settings are appropriate. If problem persists, provide alternative ventilation. Service ventilator.
1208	Alarm message: <i>Oxygen Not Available</i> Oxygen supply pressure out of range, oxygen device failed, air flow sensor and/or oxygen flow sensor calibration failed, or oxygen inlet pressure sensor calibration failed. The ventilator discontinues oxygen support.	Check patient. Check if high/low O ₂ source is the problem and correct. If problem persists, provide alternative ventilation. Service ventilator.
1209	Alarm message: <i>Low O₂ Supply Pressure</i> Oxygen supply pressure is less than 40 psig and delivered oxygen is at least 5% lower than O ₂ setting. The ventilator continues to deliver as much oxygen as possible, but ends oxygen support when oxygen inlet pressure drops to less than 18 psig. Autoresets when oxygen supply pressure exceeds 23 psig.	Check patient. Confirm that ventilator and alarm settings are appropriate. If problem persists, provide alternative ventilation. Service ventilator.
120A	Alarm message: <i>High O₂ Supply Pressure</i> O ₂ inlet pressure is greater than 92 psig, O ₂ enrichment ends. Autoresets when O ₂ supply pressure falls below 87 psig.	Check patient. If problem persists, provide alternative ventilation. Service ventilator.
120D	Alarm message: <i>Low Rate</i> A low-priority alarm if the measured respiratory rate is less than the Lo Rate setting, escalating to a high-priority alarm in 60 sec. Begins as a high-priority alarm if: <ul style="list-style-type: none"> • The Lo Rate setting is \leq 4 BPM and there are no breaths for $>$ 60/Lo Rate setting. • The Lo Rate setting is $>$ 4 BPM and there are no breaths for $>$ 15 sec. 	Check patient. Confirm that ventilator and alarm settings are appropriate. If problem persists, provide alternative ventilation. Service ventilator.

Diagnostic Mode and Troubleshooting

Table 5-1: Diagnostic Codes and Troubleshooting

Diagnostic code	Description	Recommended repair
120E	Alarm message: <i>Low Minute Ventilation</i> Estimated minute ventilation is less than the Lo \dot{V}_E setting. Escalates to a high-priority alarm if the alarm condition persists for more than 60 sec.	Check patient. Confirm that ventilator and alarm settings are appropriate. If problem persists, provide alternative ventilation. Service ventilator.
120F	Alarm message: <i>Low Tidal Volume</i> Estimated tidal volume is less than the Lo V_T setting. Escalates to a high-priority alarm if the alarm condition persists for more than 60 sec.	Check patient. Confirm that ventilator and alarm settings are appropriate. If problem persists, provide alternative ventilation. Service ventilator.
1210	Alarm message: <i>High Tidal Volume</i> Measured estimated tidal volume is greater than the Hi V_T setting. Escalates to a high-priority alarm if the alarm condition persists for more than 60 sec.	Check patient. Confirm that ventilator and alarm settings are appropriate. If problem persists, provide alternative ventilation. Service ventilator.
1211	Alarm message: <i>High Rate</i> Measured respiratory rate is greater than the Hi Rate setting. Escalates to a high-priority alarm if the alarm condition persists for more than 60 sec.	Check patient. Confirm that ventilator and alarm settings are appropriate. If problem persists, provide alternative ventilation. Service ventilator.
1212	Alarm message: <i>Running on Internal Battery</i> System is powered by internal battery. Autoresets when ventilator is connected to AC power.	Connect ventilator to AC power.
1213	Alarm message: <i>Using Default Settings</i> Displayed after power on if setting values are corrupted or not set, or if default values were restored by the user.	Check patient. Check and adjust settings as required.
1214	Alarm message: <i>AVAPS: Target Vt Not Achieved. Insufficient Max Pressure</i> AVAPS target pressure exceeds AVAPS Max P setting. The ventilator limits applied pressure to Max P.	Check patient. Confirm that pressure settings are compatible with target. Evaluate pressure and volume settings.
1215	Alarm message: <i>AVAPS: Target Vt Exceeded. Min Pressure Too High</i> AVAPS target pressure is less than Min P setting. The ventilator limits applied pressure to Min P.	Check patient. Confirm that pressure settings are compatible with target. Evaluate pressure and volume settings.

Diagnostic Mode and Troubleshooting

Table 5-1: Diagnostic Codes and Troubleshooting

Diagnostic code	Description	Recommended repair
1216	Alarm message: <i>Mask:x, Exh Port:y</i> <i>Use Menu to change</i> Displays when ventilator is turned on. Displays selected mask type and exhalation port.	Select mask and port from Menu tab. Message is removed when user confirms selections, or after 5 minutes.
1217	Alarm message: <i>Power Has Been Restored</i> Power is restored following loss of power. The ventilator restarts and continues ventilation in the mode set before power was lost.	Check patient. Confirm that ventilator and alarm settings are appropriate.
2000- 2003 Informational Diagnostic Codes (no user action required)		
2000	System startup (diagnostic).	Occurs when ventilator is power ON in diagnostic mode: no action required.
2001	System startup (ventilation).	Occurs when ventilator is powered ON in normal ventilation: no action required.
2002	System shutdown.	Occurs when ventilator is powered OFF: no action required.
2003	Restored default settings	Occurs when default settings are restored: no action required.
5xxx: Leaks Tests Diagnostic Codes		
5000	Passed high pressure leak test.	No action required.
5001	Failed high pressure leak test. Leak detected.	<ol style="list-style-type: none"> 1. Verify that oxygen source is adequate for this test. 2. Check for leaks at the oxygen fitting, oxygen filter element cap, oxygen solenoid valve, and oxygen pressure transducer. 3. Check that the oxygen solenoid valve is fully closed by verifying that there is zero flow across the oxygen flow sensor. If not, replace the oxygen solenoid valve. 4. Verify that the oxygen pressure transducer is reading correctly. If not, replace the DA PCBA.

Diagnostic Mode and Troubleshooting*Table 5-1: Diagnostic Codes and Troubleshooting*

Diagnostic code	Description	Recommended repair
5002	Failed high pressure leak test. Start pressure too low.	<ol style="list-style-type: none"> 1. Verify that oxygen source is adequate for this test. 2. Check for leaks at the oxygen fitting, oxygen filter element cap, oxygen solenoid valve, and oxygen pressure transducer. 3. Check that the oxygen solenoid valve is fully closed by verifying that there is zero flow across the oxygen flow sensor. If not, replace the oxygen solenoid valve. 4. Verify that the oxygen pressure transducer is reading correctly. If not, replace the DA PCBA.
5003	Failed high pressure leak test. Start pressure too high.	<ol style="list-style-type: none"> 1. Verify that oxygen source is adequate for this test. 2. Verify that the oxygen pressure transducer is reading correctly. If not, replace the DA PCBA.
5004	Failed high pressure leak test. Pressure rise detected.	<ol style="list-style-type: none"> 1. Verify shut off valve is closed on the that oxygen source is adequate for this test. 2. Check for leaks at the oxygen fitting. 3. Check that the oxygen solenoid valve is fully closed by verifying that there is zero flow across the oxygen flow sensor. If not, replace the oxygen solenoid valve. 4. Verify that the oxygen pressure transducer is reading correctly. If not, replace the DA PCBA.
5005	Passed system leak test.	No action required.

Diagnostic Mode and Troubleshooting

Table 5-1: Diagnostic Codes and Troubleshooting

Diagnostic code	Description	Recommended repair
5006	<p>Failed system leak test.</p> <p>Leak detected.</p>	<ol style="list-style-type: none"> 1. Verify that the internal exhalation port, air inlet port, gas outlet port and proximal port are plugged properly. 2. Verify that the system leak test syringe tubing is properly clamped. 3. Check for disconnected or cut tubing from the GDS to the gas outlet port, and from the gas outlet port to the base assembly. 4. Check for misaligned or cut rubber boots from the GDS to the blower, and from the blower to the gas outlet port. 5. Check for leaks at the flow sensor assembly, solenoid valves, and pressure transducers. 6. Verify that the machine and proximal pressure transducers are reading correctly. If not, replace the DA PCBA.

Diagnostic Mode and Troubleshooting

Table 5-1: Diagnostic Codes and Troubleshooting

Diagnostic code	Description	Recommended repair
5007	Failed system leak test. Start pressure too low.	<ol style="list-style-type: none"> 1. Verify that the internal exhalation port, air inlet port, gas outlet port and proximal port are plugged properly. 2. Verify that the system leak test syringe tubing is properly clamped. 3. Check for disconnected or cut tubing from the GDS to the gas outlet port, and from the gas outlet port to the base assembly. 4. Check for misaligned or cut rubber boots from the GDS to the blower, and from the blower to the gas outlet port. 5. Check for leaks at the flow sensor assembly, solenoid valves, and pressure transducers. 6. Verify that the machine and proximal pressure transducers are reading correctly. If not, replace the DA PCBA.
5008	Failed system leak test. Start pressure too high.	<ol style="list-style-type: none"> 1. Verify that the system leak test syringe tubing is properly clamped. 2. Verify that the machine and proximal pressure transducers are reading correctly. If not, replace the DA PCBA.
5009	Failed system leak test. Pressure rise detected.	<ol style="list-style-type: none"> 1. Verify that the system leak test syringe tubing is properly clamped. 2. Verify that the machine and proximal pressure transducers are reading correctly. If not, replace the DA PCBA.

5.5 Miscellaneous Troubleshooting Tips

Table 5-2 summarizes troubleshooting tips for the V60 ventilator. Follow the repair procedures in order until the problem is resolved.

Table 5-2: Miscellaneous Troubleshooting Tips

Symptom	Recommended repair
Cannot turn ventilator off because LCD is blank or touch screen is unresponsive.	1. Press ON/Shutdown and then release and press the nav-ring Enter button.
Unexpected touch screen response.	1. Calibrate the touch screen (section 5.3).
<i>Low Leak-CO₂ Rebreathing Risk</i> alarm occurs during performance verification oxygen accuracy test.	1. Verify test setup and that Whisper Swivel is correctly installed.
DAC ADC reference voltage failure.	1. Verify that the MC PCBA is fully seated onto the CPU PCBA.
Cooling fan does not operate when the ventilator is off and the internal battery is charging.	1. Replace fan. 2. Replace PM PCBA. 3. Replace power supply.

(This page is intentionally blank.)

Chapter 6. Reports and Software Downloads

This chapter describes how to set up and use a service PC to generate diagnostic reports, download software to the ventilator, or program the ventilator serial number.

- Section 6.1.1 describes how enable communication between a service PC and a ventilator.
- Section 6.2 describes how to generate diagnostic reports.
- Section 6.4 describes how to downloading software to the ventilator.
- Section 6.5 describes how to programming the ventilator serial number.

6.1 Setting Up the Service PC

This section describes how to set up a service PC to communicate with the ventilator. Once communication is enabled, you can generate diagnostic reports, download software to the ventilator, or program the ventilator serial number. Use either of these programs to enable PC-to-ventilator communication:

- HyperTerminal (Section 6.1.1)
- Tera Term (Section 6.1.2)

6.1.1 Setting Up the Serial Interface Using HyperTerminal

Follow these steps to set up the HyperTerminal program, which enables the ventilator to communicate to a service PC.

1. Launch the HyperTerminal program on the PC by clicking **Start > All Programs > Accessories > Communications > HyperTerminal**.
2. If the *Default Telnet Program?* screen appears, click **No** (Figure 6-1).

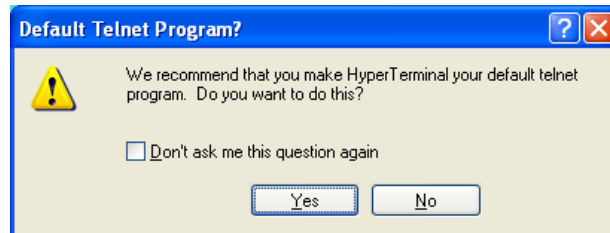

Figure 6-1: Default Telnet Program Screen

3. Enter *V60* as the name, choose an icon, then click **OK** (Figure 6-2).



Figure 6-2: Selecting the Connection Description

4. Select the appropriate COM port, then click **OK** (Figure 6-3).



Figure 6-3: Selecting the COM Port

5. Select the COM port properties, then click **OK** (Figure 6-4).

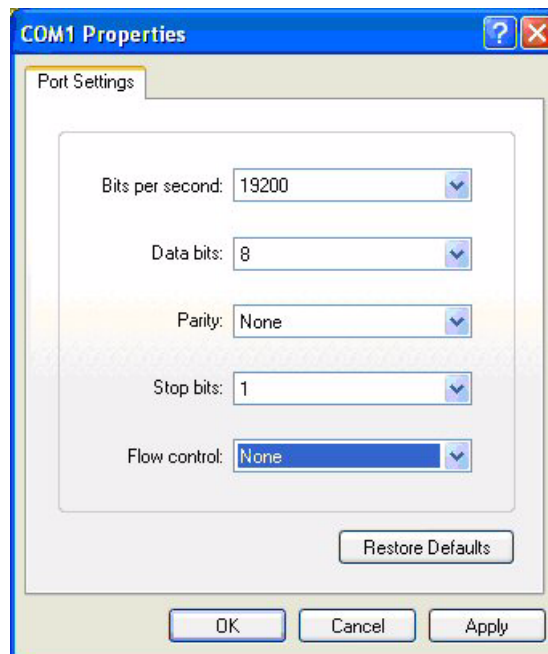

Figure 6-4: Selecting the COM Port Properties

6. At the HyperTerminal window, click **File**, then **Properties** (Figure 6-5).

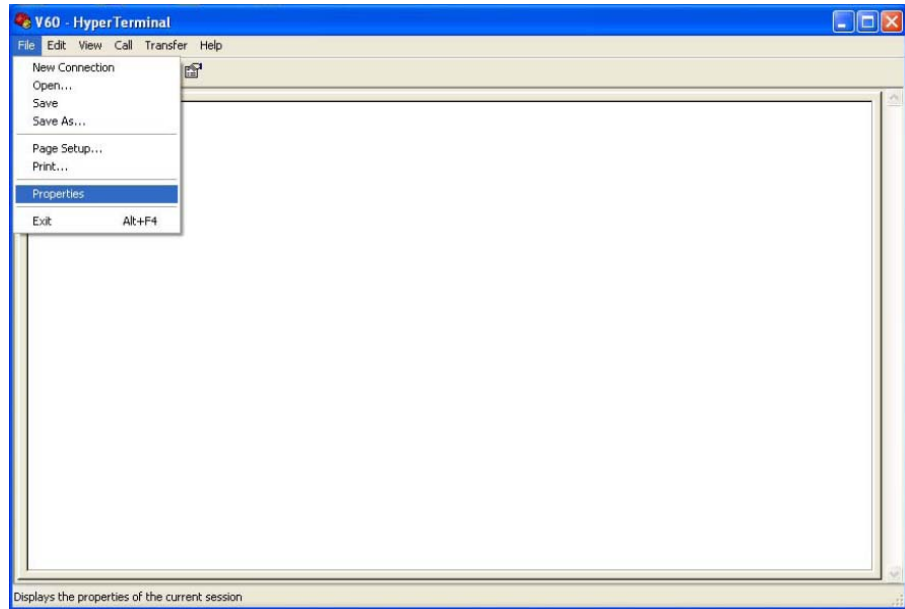

Figure 6-5: Selecting HyperTerminal Properties

7. Select these HyperTerminal settings, then click **ASCII Setup** (Figure 6-6).

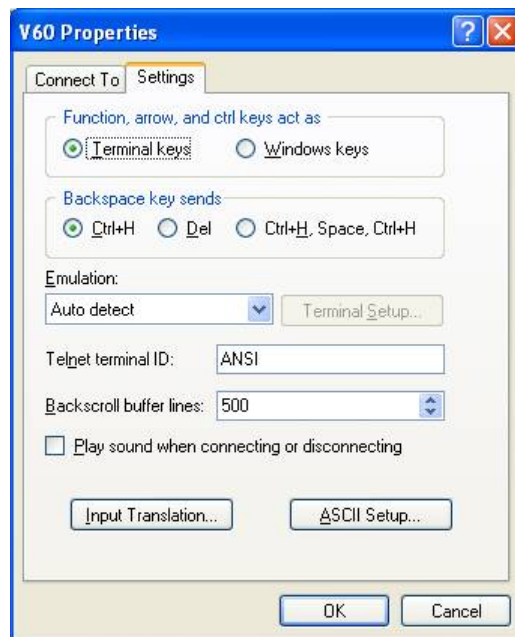

Figure 6-6: Entering HyperTerminal Settings

8. Select these ASCII settings, then click **OK** (Figure 6-7).

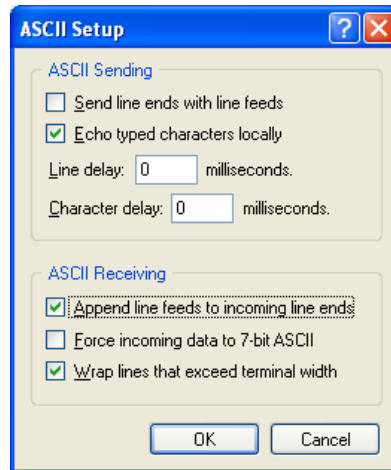

Figure 6-7: Entering ASCII Settings

9. Select **File**, then **Save As** and save the V60 icon to the Windows desktop (Figure 6-8).

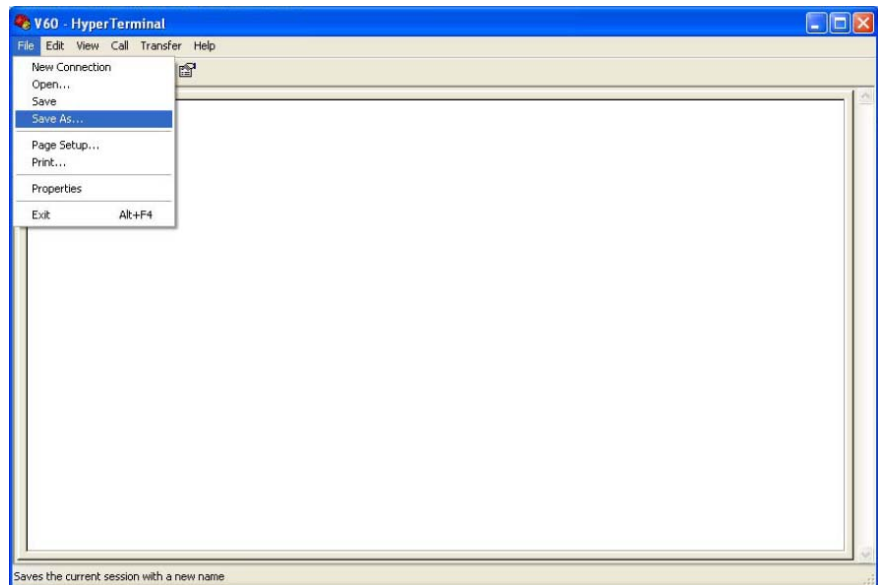

Figure 6-8: Saving the V60 Icon to the Desktop

6.1.2 Setting Up the Serial Interface Using Tera Term

Follow these steps to set up the Tera Terminal program, which enables the ventilator to communicate to a service PC.

1. From your web browser go to: <http://tssh2.sourceforge.jp/>, then click the **download page** link.
2. Click on **teraterm-x.xx.exe**.

NOTE: If your PC does not allow the download, follow the instructions for “click this link.”

3. Click **Run** on the **File Download** screen (Figure 6-9).

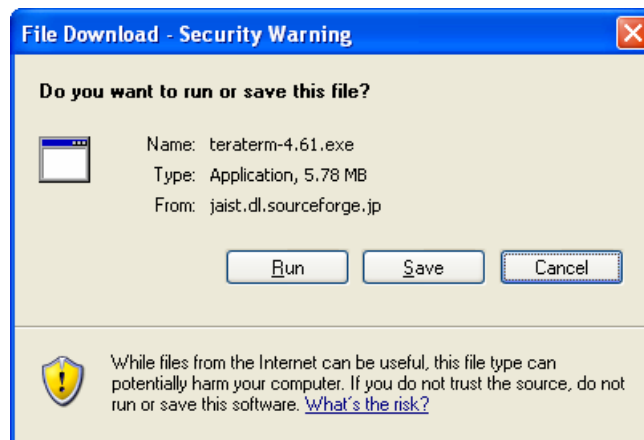

Figure 6-9: File Download Screen

4. A progress screen is displayed during the file download (Figure 6-10).

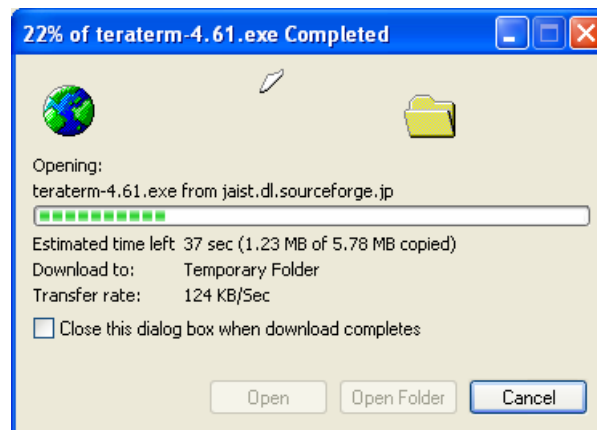

Figure 6-10: File Download

5. When the file download is complete, click **Run** (Figure 6-11).

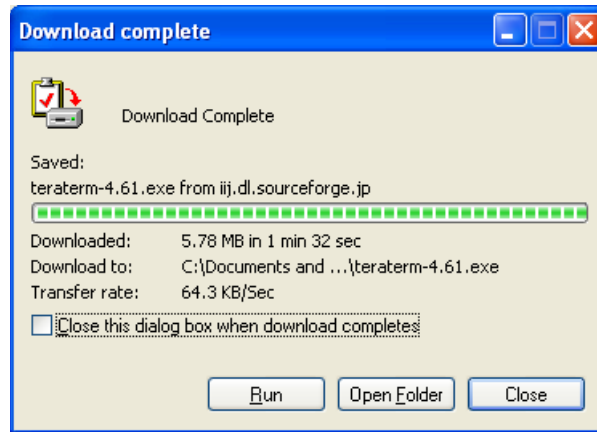

Figure 6-11: File Download Complete

6. If the security warning screen appears, click **Run** (Figure 6-12).

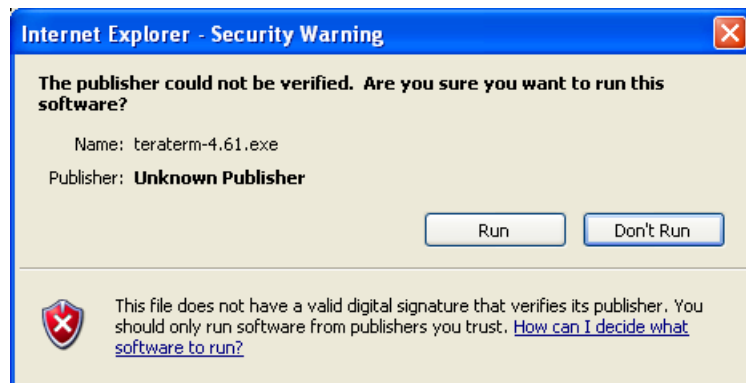

Figure 6-12: Internet Explorer Security Warning

7. When the Tera Term setup screen appears, click **Next** (Figure 6-13).

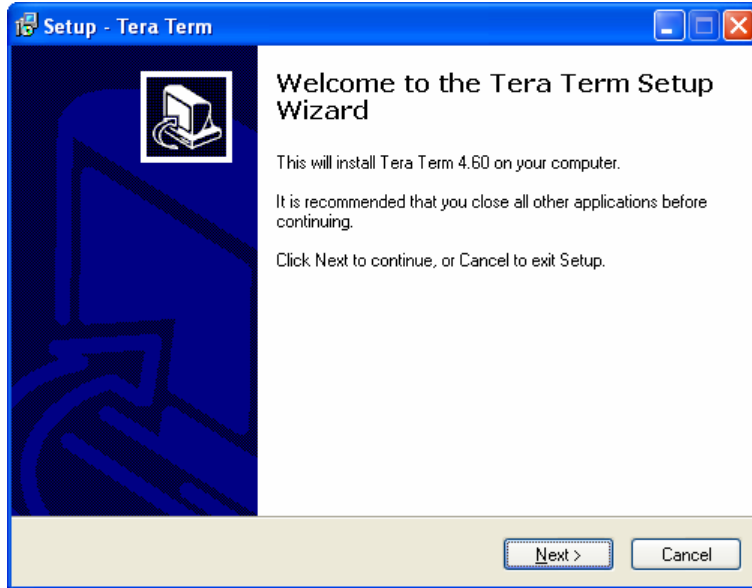

Figure 6-13: Tera Term Setup Screen

8. Click the **I accept the agreement** radio button, then click **Next** (Figure 6-14).

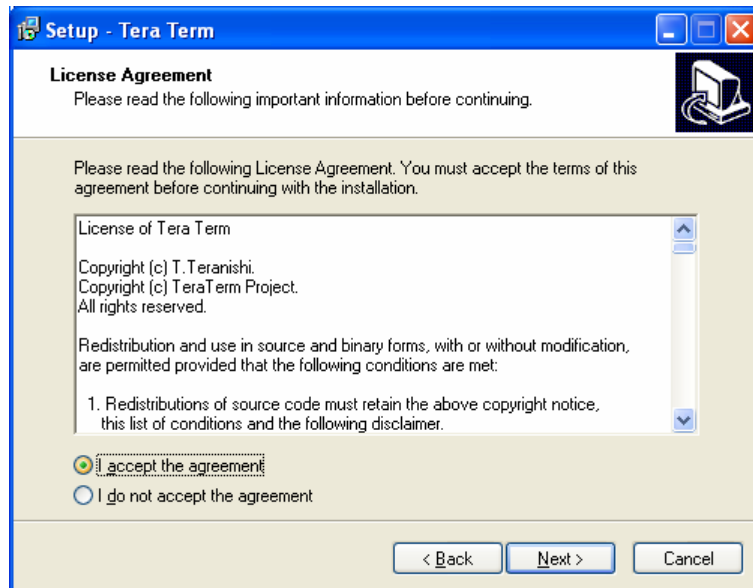

Figure 6-14: Tera Term License Agreement Screen

9. Select a destination, then click **N**ext (Figure 6-15).

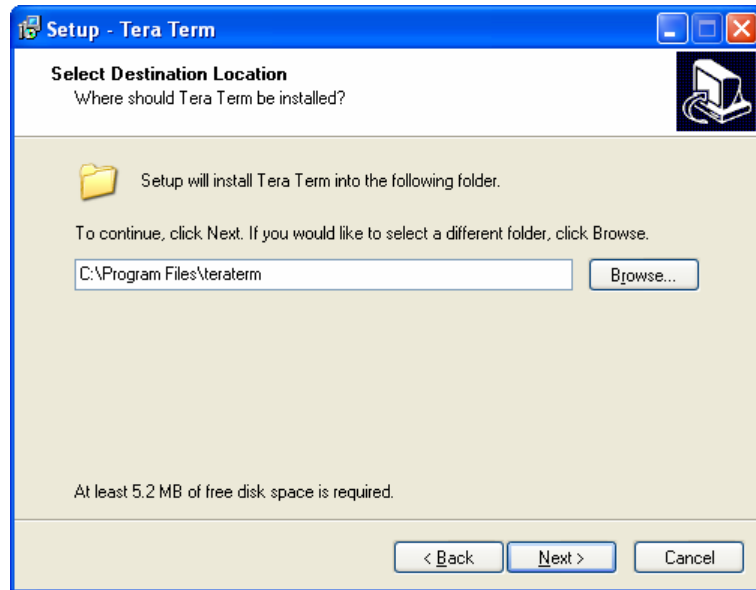

Figure 6-15: Destination Location Screen

10. Select **Standard installation** on the Select Components screen, then click **N**ext (Figure 6-16).

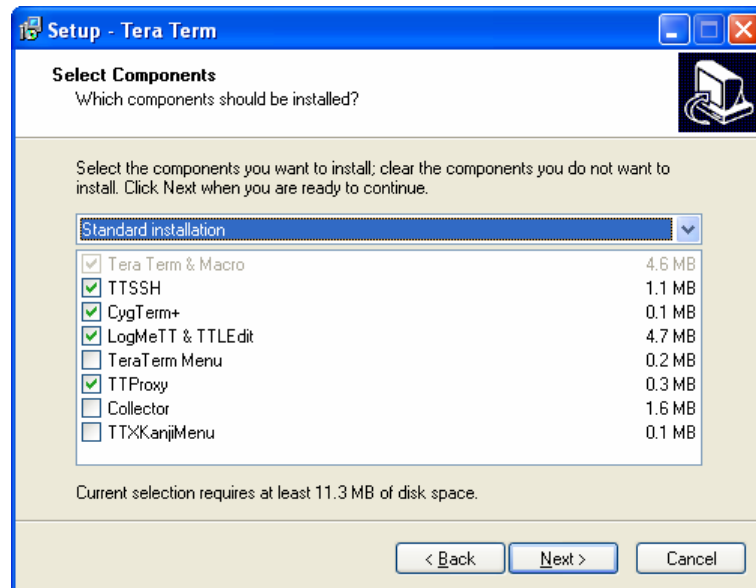

Figure 6-16: Select Components Screen

11. Select a language, then click **N**ext (Figure 6-17).

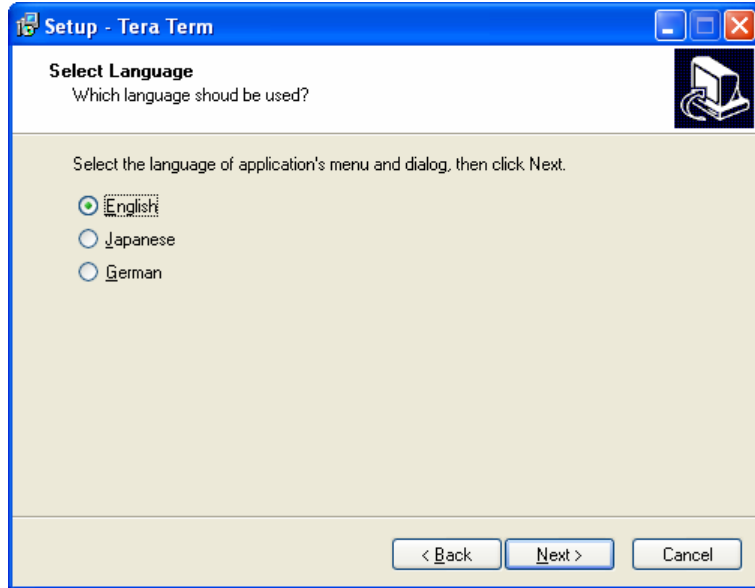

Figure 6-17: Select Language Screen

12. At the Select Start Menu screen, click **N**ext (Figure 6-18).

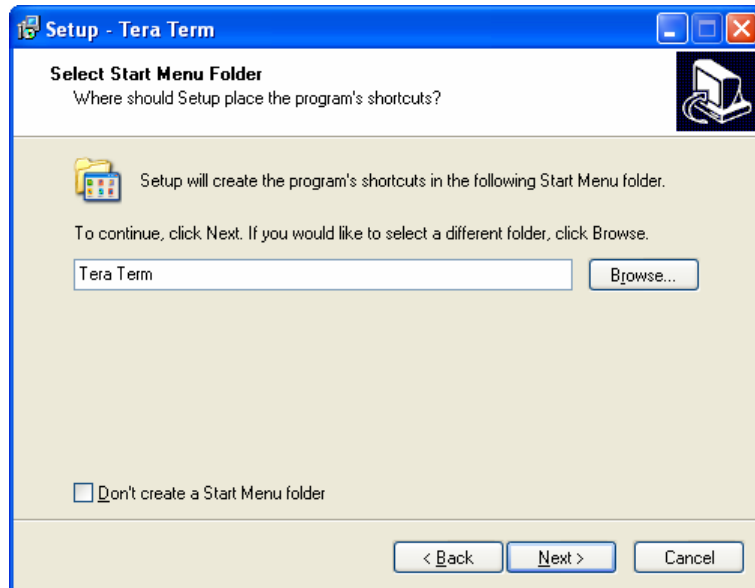

Figure 6-18: Select Start Menu Screen

13. At the Select Additional Tasks screen select **Create Tera Term shortcut to Desktop**, then click **Next** (Figure 6-19).

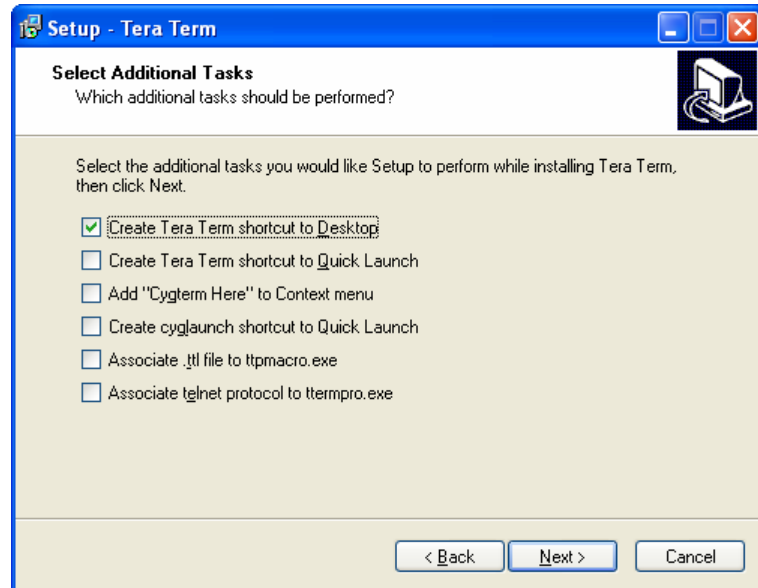

Figure 6-19: Select Additional Tasks Screen

14. At the Ready to Install screen, then click **Install** (Figure 6-20).

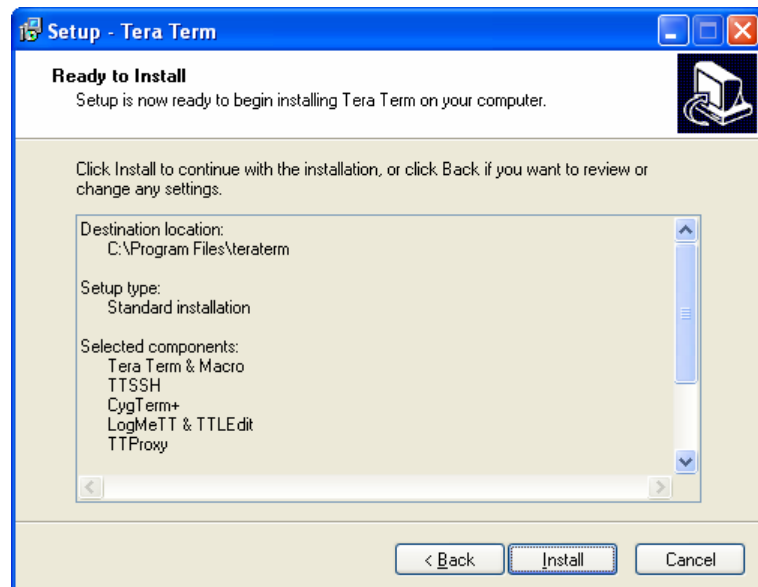

Figure 6-20: Ready to Install Screen

15. Tera Term begins installing on your PC (Figure 6-21).

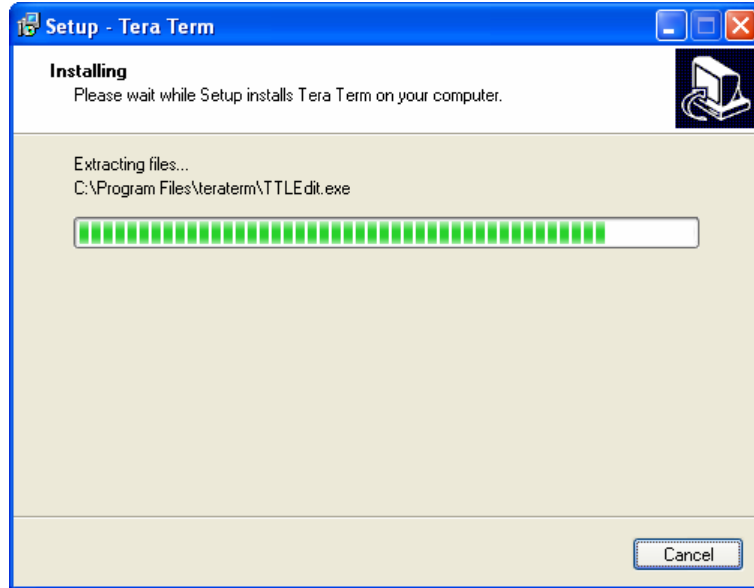

Figure 6-21: Tera Term Installing Screen

16. At the Completing the Tera Term Setup screen, click **Launch Tera Term**, then click **Finish** (Figure 6-22).

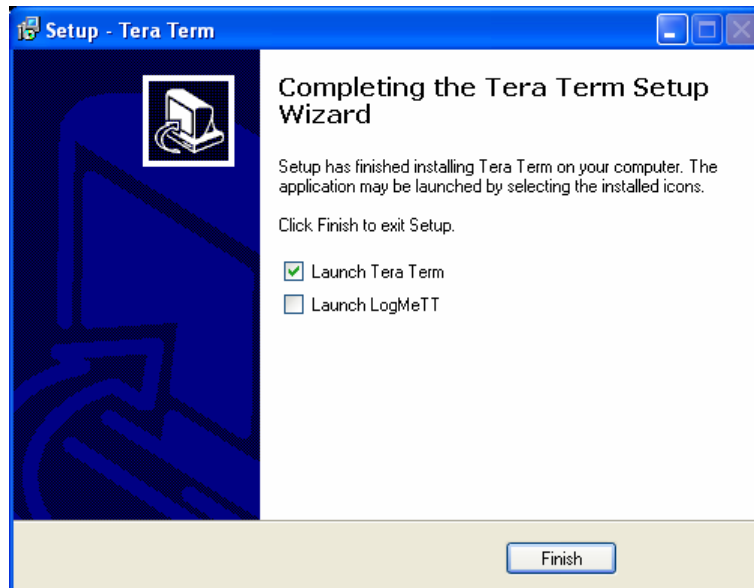

Figure 6-22: Completing the Tera Term Setup Screen

17. Once the Tera Term Setup is installed, the New Connection screen appears (Figure 6-23).

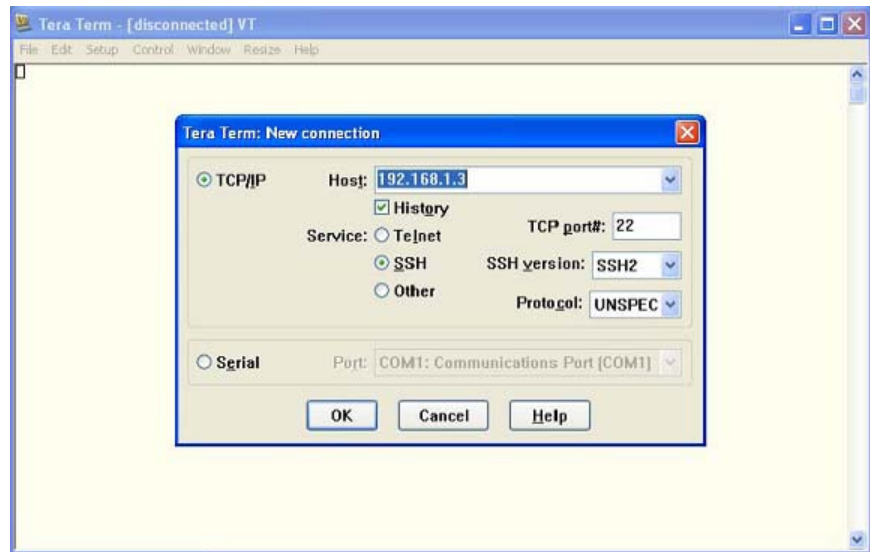

Figure 6-23: Tera Term New Connection Screen

18. Select the **Serial** radio button, then click **OK** (Figure 6-24).

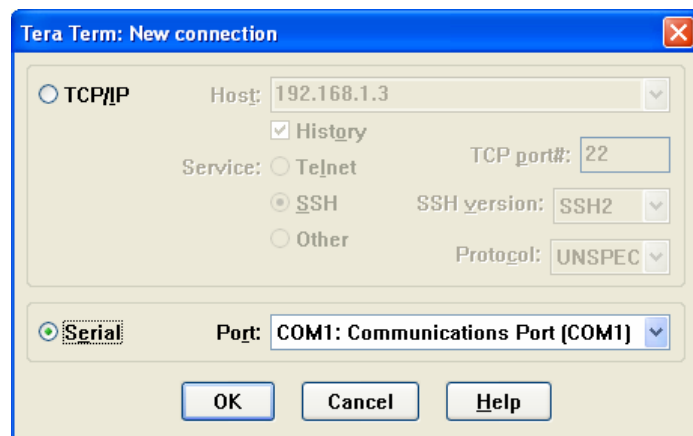

Figure 6-24: Selecting a Serial Connection

19. Select **S**etup, then click **S**erial port (Figure 6-25).

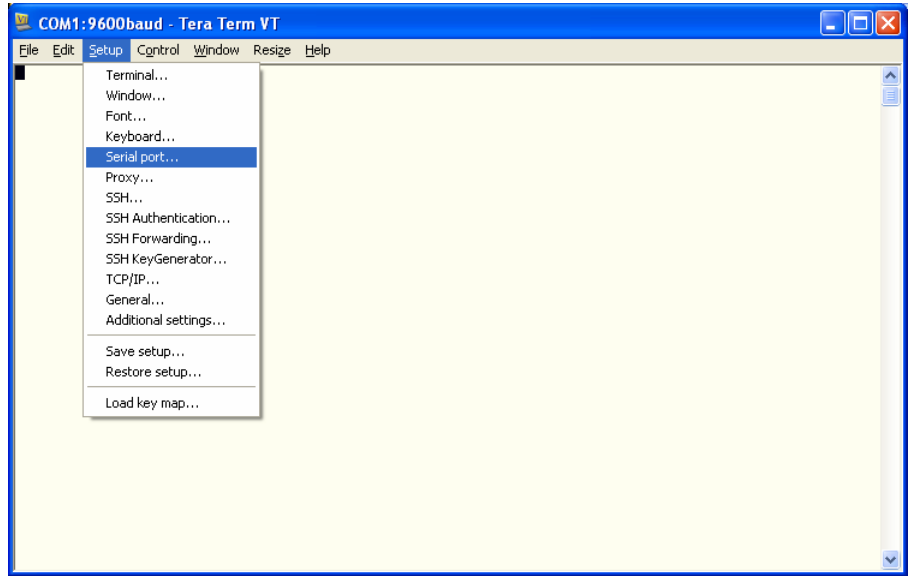

Figure 6-25: Selecting the Serial Port Setup

20. Select these serial port properties, then click **O**K (Figure 6-26).

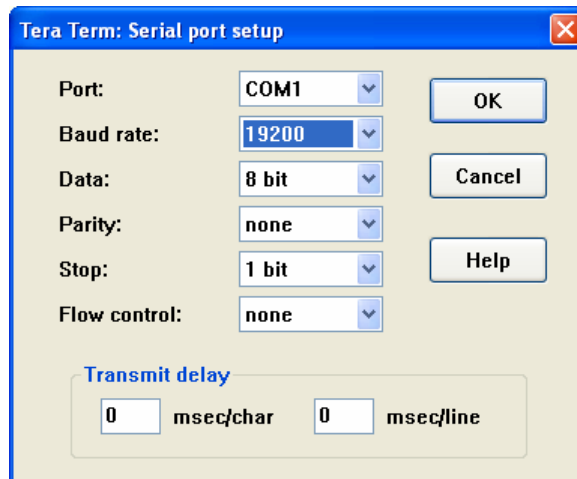

Figure 6-26: Serial Port Setup Screen

21. Select **Setup**, then click **Terminal** (Figure 6-27).

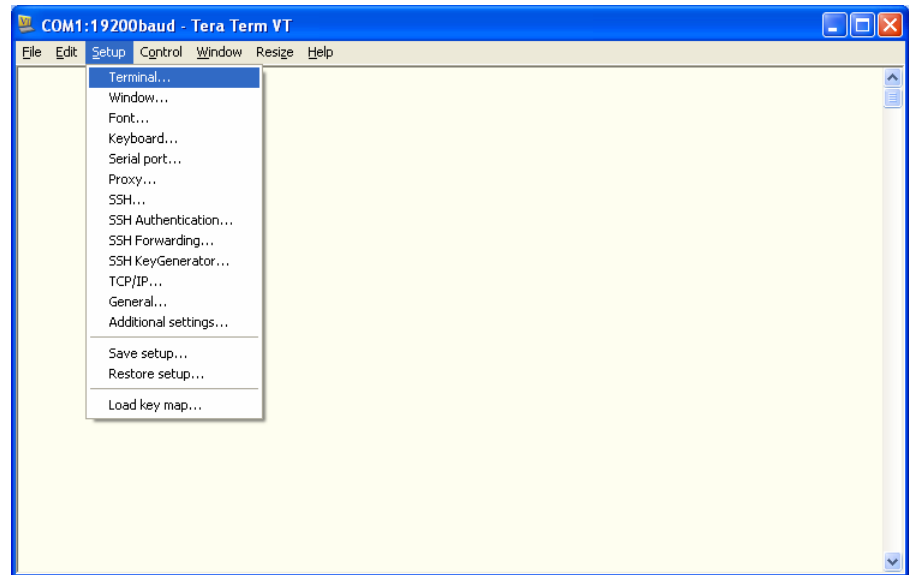

Figure 6-27: Selecting the Terminal Setup

22. Select these terminal properties, then click **OK** (Figure 6-28).

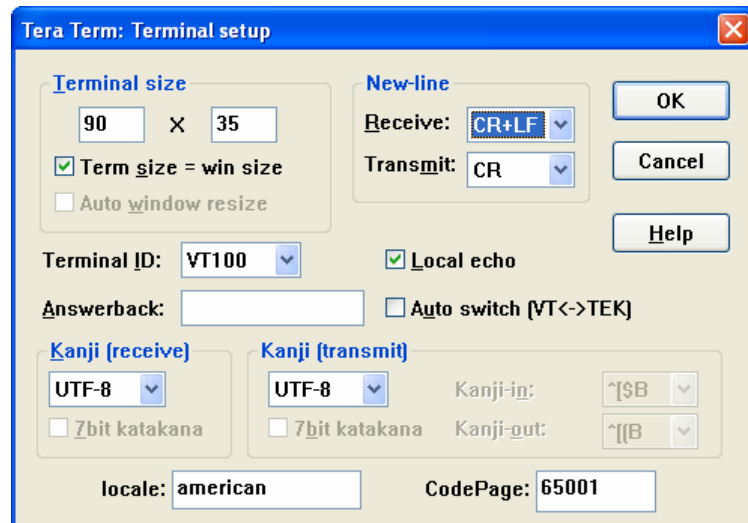

Figure 6-28: Terminal Setup Screen

23. Select **Setup**, then click **Save setup** (Figure 6-29).

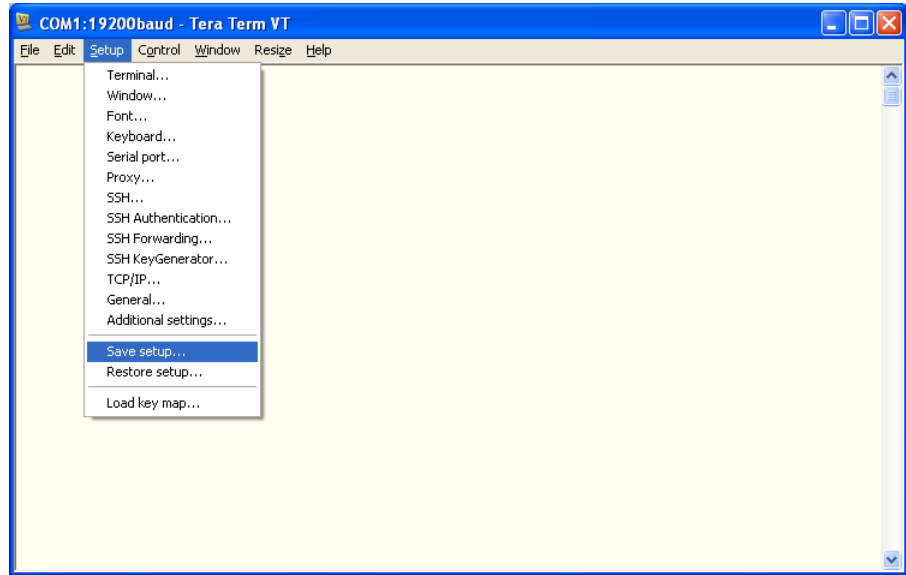

Figure 6-29: Saving the Tera Term Setup

24. At the Save setup screen, click **Save** (Figure 6-30).

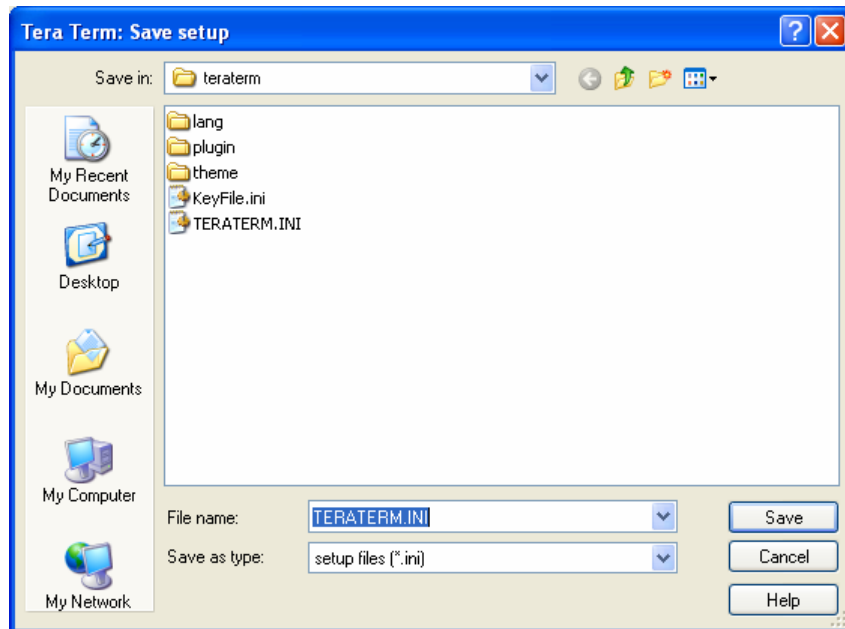

Figure 6-30: Tera Term Save Setup Screen

6.2 Generating a Diagnostic Report (DRPTA)

The DRPTA command allows you to save ventilator diagnostic codes to your PC.

NOTE: Do not connect the null modem cable until instructed to do so.

1. Place the ventilator in diagnostic mode.
2. Connect the 25-pin to 9-pin adapter and a null modem cable between the ventilator COM port and the service PC.
3. Click on the HyperTerminal or Tera Term icon to launch the program that communicates with the V60 ventilator.
4. Type **DRPTA** (all caps) in the dialog box (Figure 6-31), and press **Enter**.

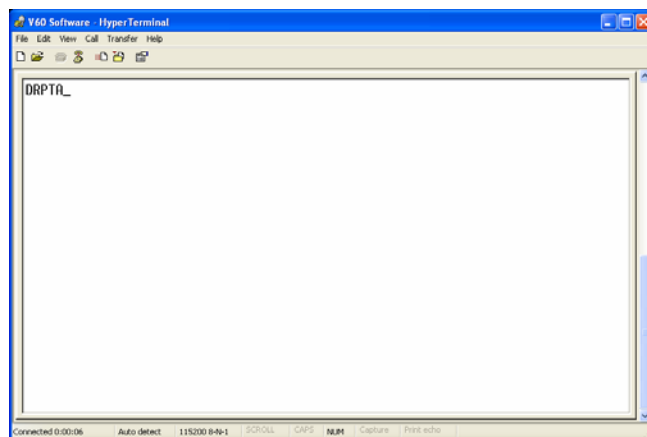

HyperTerminal dialog box

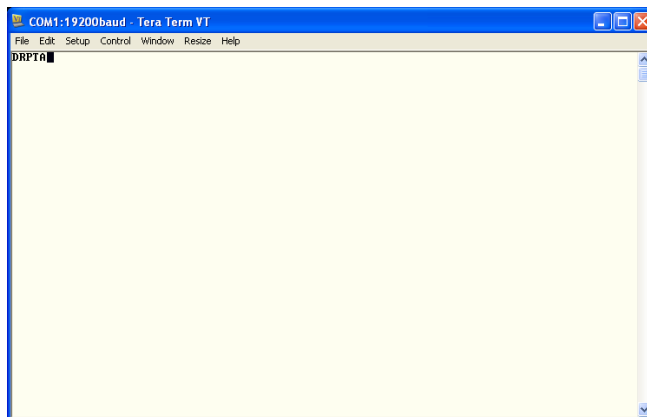

Tera Term dialog box

Figure 6-31: Entering the DRPTA Command

5. If the command is successful, a DRPTA appears (Figure 6-32).

The image displays two screenshots of diagnostic reports (DRPTA) from a V60 ventilator. The top screenshot is a HyperTerminal window titled 'V60 - HyperTerminal' showing a report for 'DRPTA,06:20,2000,06:09:41AM,01-26-2009, System Startup (Diagnostic)'. The report lists various system events such as 'System Shutdown', 'System Startup (Diagnostic)', and 'UsingDefaultSettings' with corresponding timestamps and dates. The bottom screenshot is a Tera Term window titled 'COM1:19200baud - Tera Term VT' showing a similar report for 'DRPTA,06:15,2000,06:09:41AM,01-26-2009, System Startup (Diagnostic)'. This report also lists system events and includes a 'SettingPressureUnit 1, 0' entry. Both reports are formatted as plain text with a consistent structure of timestamp, date, and event description.

Figure 6-32: Example Diagnostic Report (DRPTA)

6. Figure 6-33 shows example lines of a DRPTA report and how to interpret them.



Figure 6-33: Interpreting the DRPTA Report

6.3 Clearing the Significant Event Log

The #CLRLOG command allows you to use your PC to clear the significant event log.

CAUTION: Only qualified service technicians are to clear the significant event log.

NOTE: Do not clear the significant log until you have used the DRPTA command to save the information to your PC using HyperTerminal or Tera Term.

1. Enter Diagnostic mode by pressing and holding the nav-ring **Enter** button and turn on the ventilator by pressing the **On/Shutdown** button. Within 5 seconds, press the nav-ring **Enter** button again to enter Diagnostic mode.
2. Connect the 25-pin to 9-pin adapter and null modem cable between the ventilator COM port and the service PC.
3. Click on the HyperTerminal or Tera Term icon to launch the program that communicates with the V60 ventilator.
4. Type: **#CLRLOG** (all caps) in the dialog box, and press **Enter** to clear the diagnostic log (Figure 6-34).

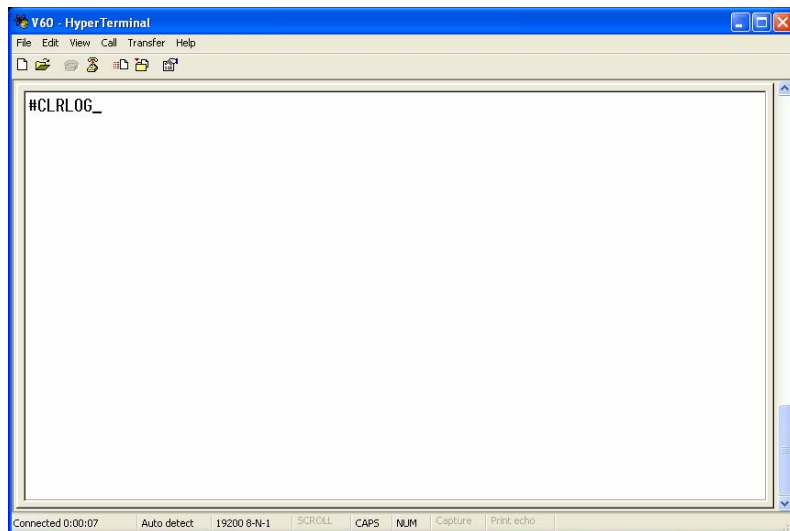

Figure 6-34: Clear Diagnostic Codes Command

5. When the diagnostic log has been successfully cleared, the dialog box displays this response:

?CLRLOGOK

6. Clearing the diagnostic log is complete.

6.4 Downloading Ventilator Software

Use the Respi-Link Remote Diagnostic System to download V60 ventilator software. If your institution is not Respi-Link capable, contact Respirationics to request Respi-Link information from your local Field Service Specialist or Regional Service Provider.

If your institution is Respi-Link capable, contact Respirationics to have a software package deployed. See Appendix A for installation instructions using Respi-Link.

NOTE: Note: If you have replaced the CPU PCBA, please contact Respirationics to have your local Field Service Specialist or Regional Service Provider install the software for you.

For technical support and customer service, contact:

USA and Canada: 800-345-6443 or 724-387-4000

Respirationics Europe, Africa, Middle East: +33-1-47-52-30-00

Respirationics Asia Pacific: +852-3194-2280

6.5 Programming the Ventilator Serial Number and Power-On Hours

The ventilator serial number and power-on hours must be re-programmed to the CPU PCBA whenever you replace the CPU PCBA.

CAUTION: Only qualified service technicians are to program the ventilator serial number and power-on hours.

NOTE: V60 ventilator software must be installed before programming the ventilator serial number or power-on hours.

6.5.1 Programming the Ventilator Serial Number

NOTE: Do *not* connect the null modem cable until instructed to do so.

Follow these steps to re-program the ventilator serial number to a new CPU PCBA:

1. Enter Diagnostic mode by pressing and holding the nav-ring **Enter** button and turn on the ventilator by pressing **On/Shutdown**. Within 5 seconds, press the nav-ring **Enter** button again to enter Diagnostic mode.
2. Turn on the PC and connect a standard 9-pin male/female RS 232 null modem cable and a 9-pin to 25-pin female/male adapter between the PC serial port and the V60 ventilator.
3. Click on the HyperTerminal or Tera Term icon to launch the program that enables communication with the V60 ventilator.

4. Type:

#PCNFGxxxxxxx

(all caps) in the dialog box (xxxxxxx is the ventilator serial number), and press **Enter** (Figure 6-35).

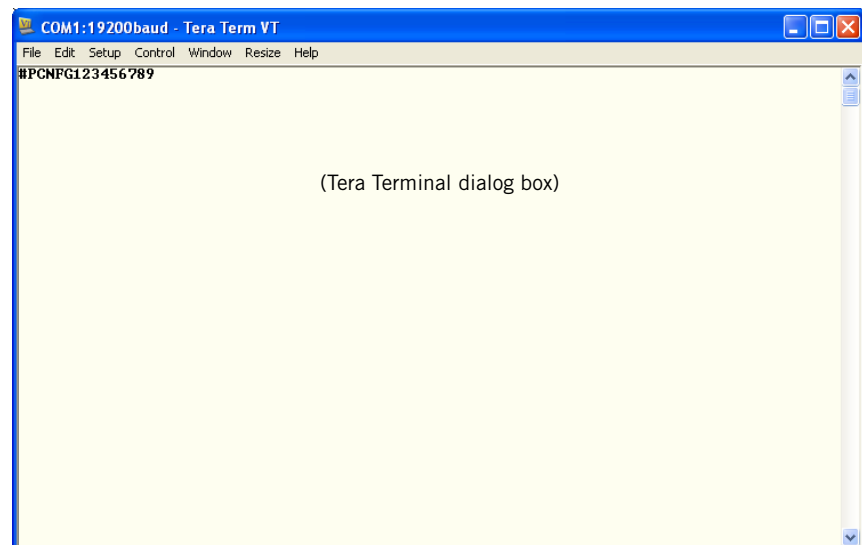
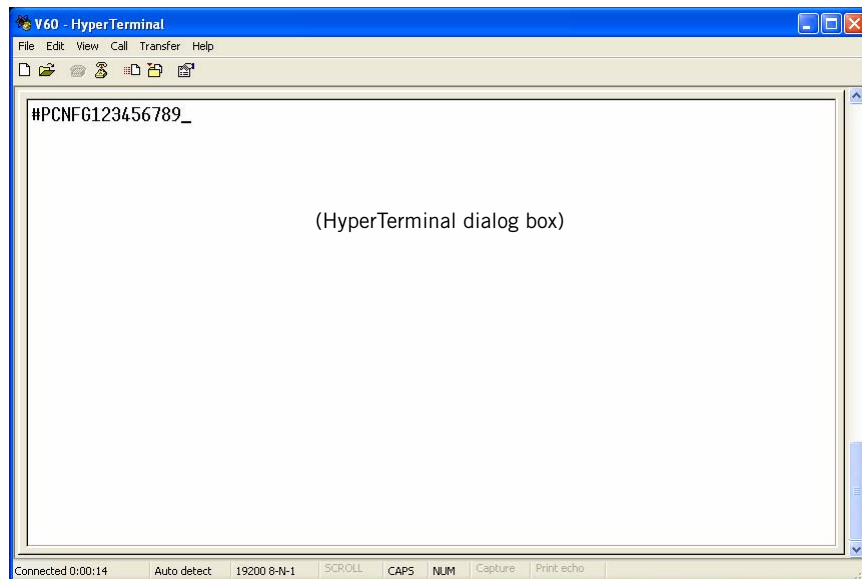

Figure 6-35: Ventilator Serial Number Programming Command

5. The V60 ventilator stores the serial number and the dialog box displays this response: *?CFGOK*
6. Touch **Misc** then **Vent Info**, and verify that the serial number displayed on the Vent Info screen matches the ventilator serial number.
7. Programming the serial number is complete.

6.5.2 Programming Ventilator Power-On Hours

NOTE: Do *not* connect the null modem cable until instructed to do so.

Follow these steps to re-program the ventilator power-on hours to a new CPU PCBA:

1. If the ventilator is not already in Diagnostic mode, press and hold the nav-ring **Enter** button and turn on the ventilator by pressing the **On/Shutdown** button. Within 5 seconds, release and press the nav-ring **Enter** button again to enter Diagnostic mode.
2. Turn on the PC and then connect a standard 9-pin male-female RS-232 null modem cable and 9-pin to 25-pin female-male adapter between the PC serial port and the V60 ventilator.
3. Click on the HyperTerminal or Tera Term icon to enable communication with the V60 ventilator.
4. Type:

#SETOPTIME

(all caps) with the additional information listed in the table below separated by a comma (Table 6-1).

Table 6-1: Power-On Hours Command Format

Field	Description
Operating time ID	0 = Total power-on hours 1 = CPU PCBA 2 = PM PCBA 3 = MC PCBA 4 = DA PCBA 5 = Oxygen flow sensor PCBA 6 = Air flow sensor PCBA
Hours	Must be 6 digits, zero padded (for example: 001234), up to a maximum of 596523.

Reports and Software Downloads

- For example, this command sets the total power-on hours to 1234 hours:

#SETOPTIME0,001234

#SETOPTIME0,001234

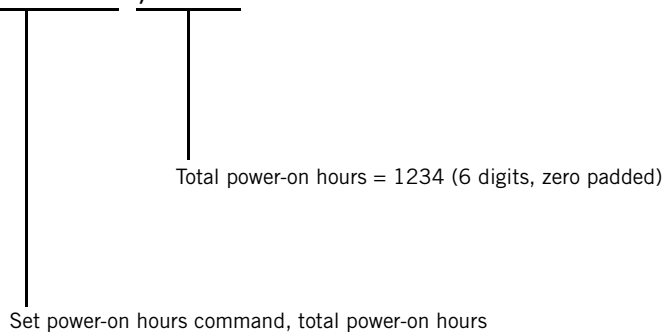

Figure 6-36: Power-On Hours Command Format

- Programming the power-on hours is complete.

Chapter 7. Component Removal/Installation

This chapter describes how to remove and install the replaceable components in the V60 ventilator.

WARNING: To avoid personal injury, disconnect all power from the ventilator before servicing or cleaning.

CAUTION: Component removal and installation is to be performed only by a qualified service technician.

CAUTION: To avoid equipment damage due to static electricity, perform all repairs in an antistatic, electrostatic discharge (ESD)-protected environment.

CAUTION: Replacing the CPU PCBA deletes the serial number, significant event log entries, and ventilator preferences. Review the significant event log before removing the CPU PCBA.

CAUTION: The gas delivery subsystem (GDS) must be leak tested if you replace any of these components:

- Data acquisition (DA) PCBA
 - Oxygen inlet filter
 - Oxygen solenoid valve
 - Oxygen filter cap
-

7.1 Disconnecting Power

Follow these steps to disconnect AC and battery power.

1. Shut down and then unplug the ventilator.
2. Disconnect the internal battery from the power harness connector (Figure 7-1).

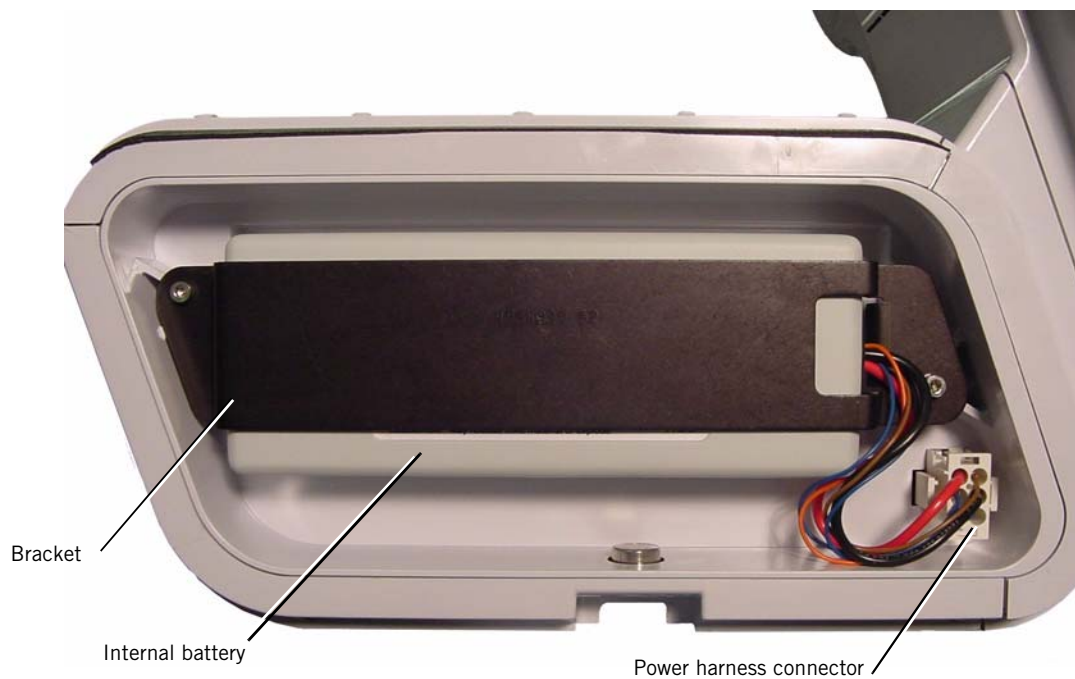

Figure 7-1: Disconnecting the Internal Battery

7.2 Air Inlet Filter

Follow these steps to remove the air inlet filter (Figure 7-2). Reverse to install.

1. Turn the unit OFF and disconnect the power cord from the outlet.
2. Twist the locking pin 1/4 turn with a slotted screwdriver or by hand, and pull down on locking pin to remove right side panel (locking pin is captive).
3. Remove air inlet filter.



Figure 7-2: Removing the Air Inlet Filter

7.3 Internal Battery

Follow these steps to remove and install the internal battery (Figure 7-3).

1. Disconnect power (section 7.1).
2. Disconnect the internal battery from the power harness connector.
3. Remove the side panel by turning the captive Phillips head fastener a 1/4 turn and releasing.
4. Using a 3-mm hex wrench, remove the battery bracket by removing two screws.

Component Removal/Installation

5. Holding the battery so that the vent hole faces up and the Philips logo faces out, thread the battery cable through the battery bracket. Position and place the battery inside the battery compartment. Pinching the end of the battery connector, plug it in so that it locks in place.
6. Reinstall the battery bracket by replacing the two screws. Reinstall the side panel and secure the fastener with a 1/4 turn clockwise.
7. Make sure the battery is properly installed by plugging the ventilator into an AC power receptacle and verifying that the yellow Battery (charged) LED on the front panel flashes. The flashing LED indicates the battery is being charged.
8. If necessary, attach the option label.

NOTE:

When installing a new battery:

- The battery must be charged for at least 5 hours before being placed into service.
- Dispose of the old battery according to your institution's protocol. Follow all local, state, and federal regulations with respect to environmental protection.

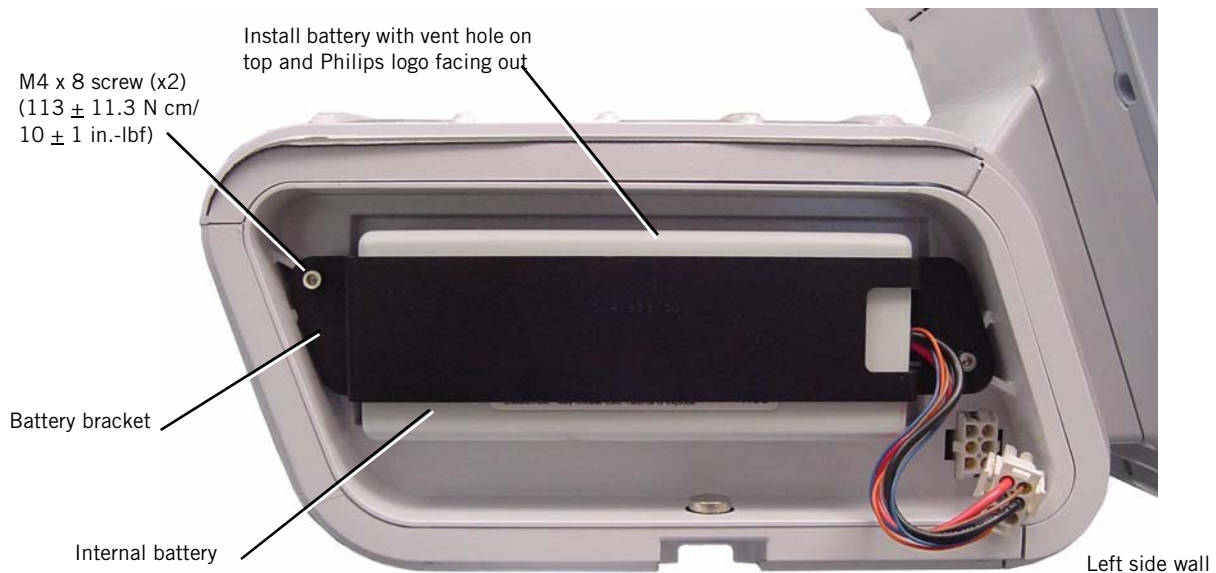

Figure 7-3: Removing the Internal Battery

7.4 Top Cover

Follow these steps to remove the top cover (Figure 7-4). Reverse to install.

1. Disconnect all power (section 7.1).
2. Turn and pull down on the locking pin to remove right side panel (locking pin is captive).
3. Remove the screws that attach the top cover, then remove the top cover.

M4 x 8 screw (x4)
(113 ± 11.3 N cm
 10 ± 1 in.-lbf)

Top cover



Figure 7-4: Removing the Top Cover

Component Removal/Installation

7.5 AC Inlet

Follow these steps to remove the AC inlet (Figure 7-5). Reverse to install.

1. Remove top cover (section 7.4).
2. Remove EMI shroud from power supply (section 7.16).
3. Remove the screws that attach the power cord retainer, then remove retainer and power cord.
4. Remove screws that attach the AC inlet to the back panel.
5. Disconnect AC inlet cables from power supply and ground terminal.
6. Feed cable through back panel cutout, and pull AC inlet from back panel.

CAUTION: Install ground wires and nuts in this order to ensure proper grounding:

1. Kep nut
2. AC inlet wire
3. Kep nut
4. Power supply connector wire
5. GDS ground wire
6. Kep nut

NOTE: When reinstalling, orient the AC inlet with ground terminal as shown.

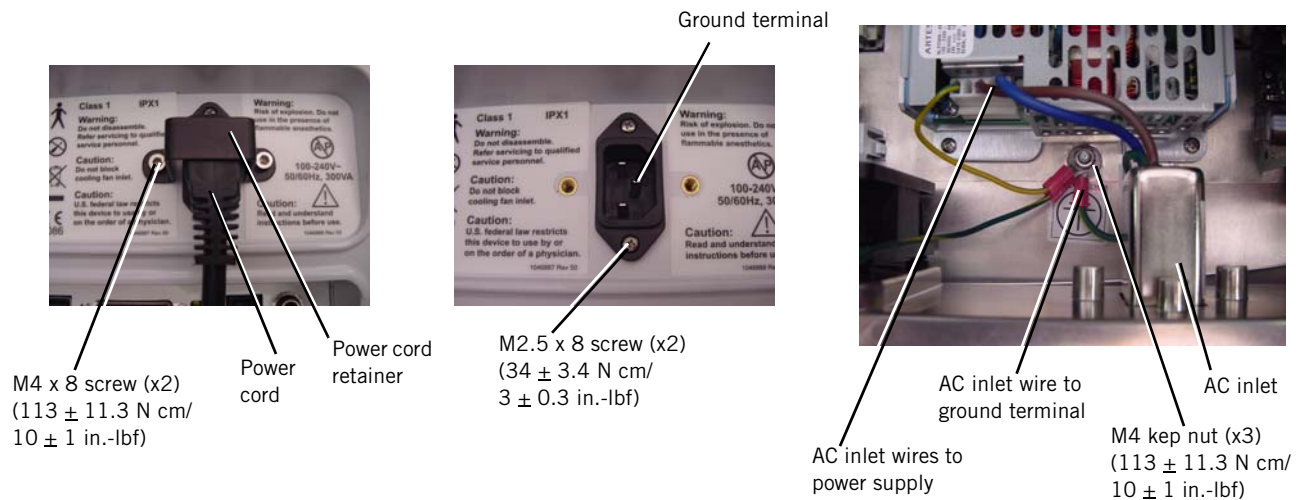

Figure 7-5: Removing AC Inlet

7.6 Fan

Follow these steps to remove the fan (Figure 7-6). Reverse to install.

NOTE: See Chapter 4 for fan filter replacement instructions.

1. Remove top cover (section 7.4).
2. Remove fan mount push pins that attach the fan to the back panel (pliers may be required).
3. Disconnect fan cable from the motor controller (MC) PCBA.
4. Remove the fan from inside the back panel.
5. Remove fan filter assembly (fan filter and housing) from outside the back panel.

NOTE: When installing, orient the fan as shown (cable at the top inside of the fan). Orient the fan filter and housing as shown.

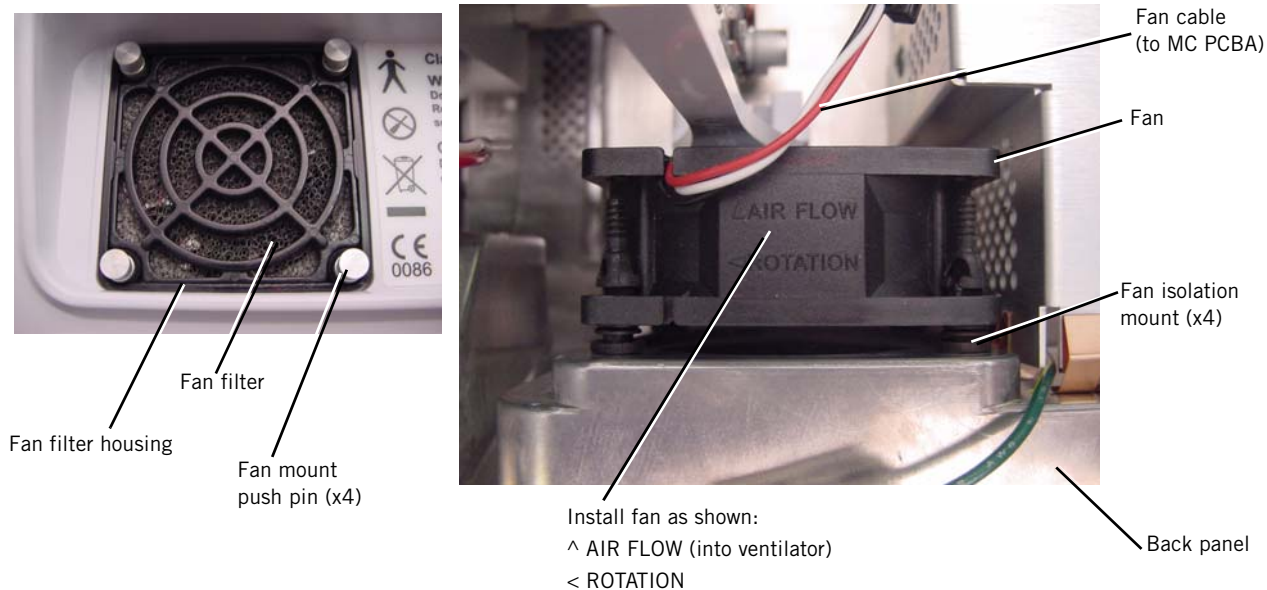

Figure 7-6: Removing the Fan

7.7 Oxygen Inlet

Follow these steps to remove the oxygen inlet (Figure 7-7). Reverse to install.

1. Disconnect all power (section 7.1).
2. Loosen the screws that attach the retaining bracket to the GDS, then remove the bracket.
3. Pull to remove the oxygen inlet.



M3 screw (x2)
(113 ± 11.3 N cm/
10 ± 1 in.-lbf)
Washer (x2)

Oxygen inlet

Retaining bracket

Figure 7-7: Removing the Oxygen Inlet

7.8 Motor Controller (MC) PCBA

Follow these steps to remove the MC PCBA (Figure 7-8). Reverse to install.

1. Remove top cover (section 7.4).
2. Remove the screws and wing nuts that attach the MC PCBA to the PCBA brackets.
3. Loosen the captive screws that attach the capacitor bracket to the base.
4. Disconnect cables:
 - Blower cable
 - Fan cable
 - DA-MC ribbon cable
5. Gently pull MC PCBA up from its connection on the CPU PCBA, then disconnect speaker #1 cable.
6. Remove PCBA brackets.

NOTE: To avoid bending connector pins, reinstall the MC PCBA, and then the PCBA brackets. Verify that the MC PCBA does not protrude above the brackets.

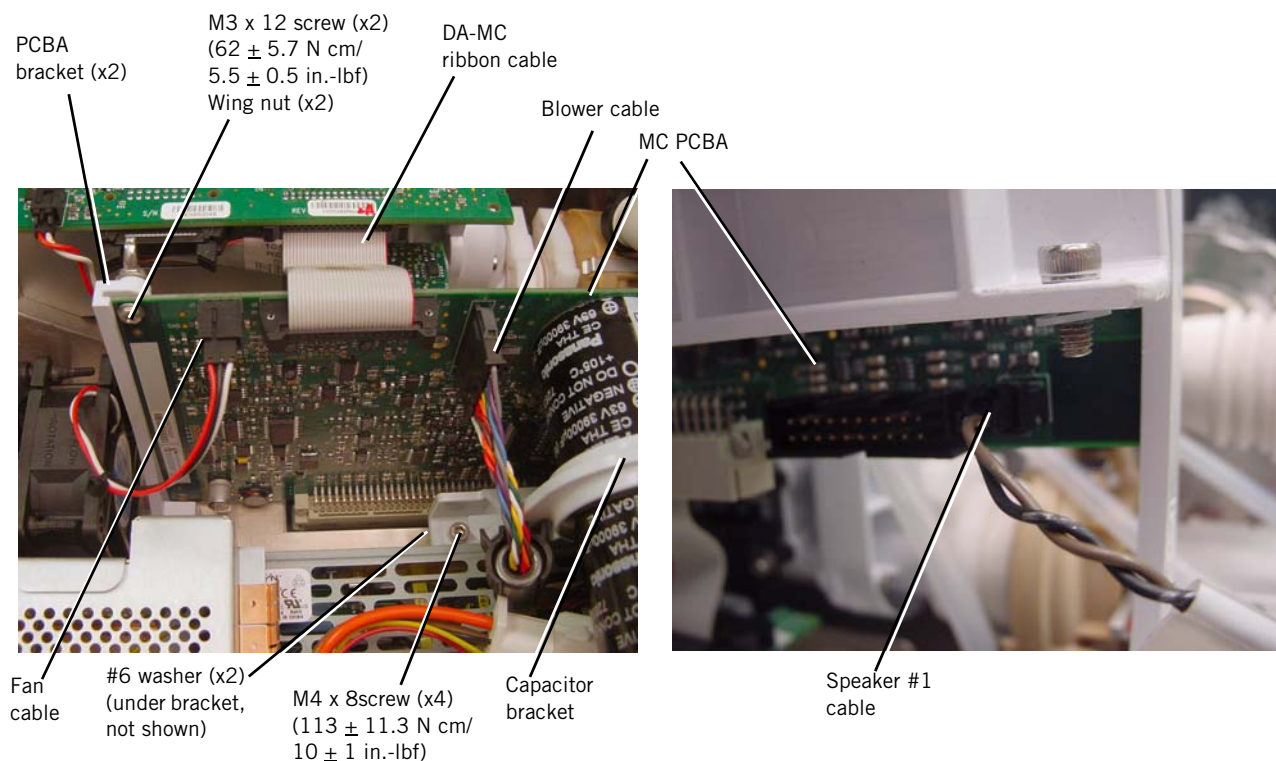

Figure 7-8: Removing the MC PCBA

7.9 Separating the UI from the Base

Follow these steps to separate the UI from the base (Figure 7-9). Reverse to install.

NOTE: When connecting the LCD cable to the PM PCBA, ensure that the connector tab faces the front panel.

NOTE: After installing a new UI assembly, perform the touch screen calibration (section 5.3).

1. Remove top cover (section 7.4).
2. Remove MC PCBA (section 7.8).
3. Disconnect cables:
 - LCD cable from PM PCBA.
 - LCD cable ground wires from the ground terminal.
 - LCD tray ground wires from the ground terminal.
 - UI cable (ribbon cable) from the PM PCBA.
4. Loosen the captive screw that attaches the UI retainer to the UI.
5. Slide retainer up, then remove UI from base.

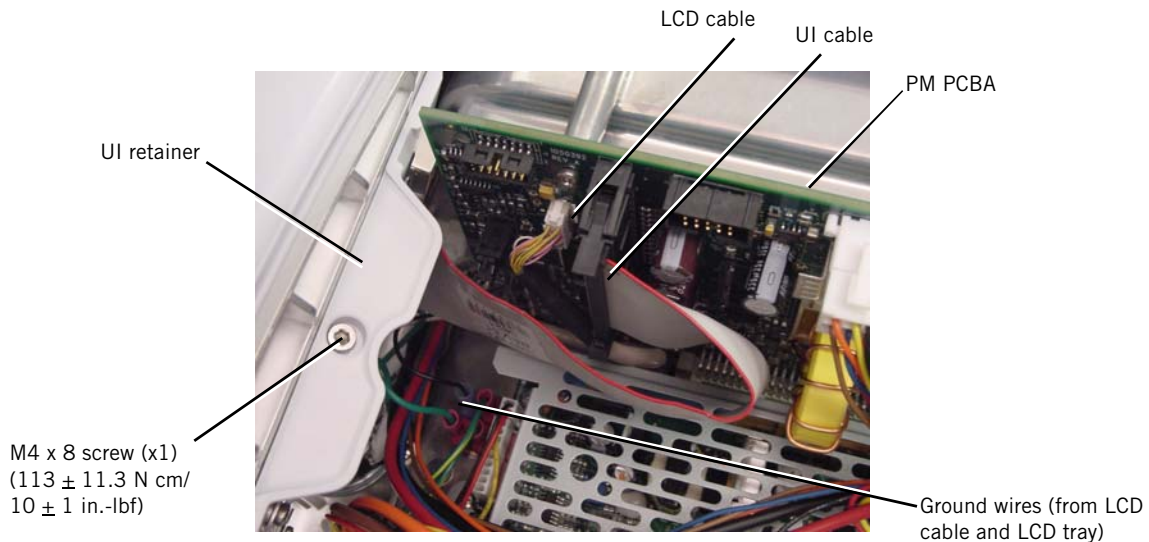

Figure 7-9: Separating the UI from the Base

7.10 Front Panel

Follow these steps to remove the front panel (Figure 7-10). Reverse to install.

1. Separate UI from base (section 7.9).
2. Remove hose clamp and boot that attach blower to the gas outlet.
3. Remove the tubing from the barbed fittings inside the front panel.
4. Disconnect gas outlet and proximal port ground wires from the base.
5. Remove the screws that attach the front panel to the base and side walls.

NOTE: When reinstalling tubing, ensure that:

- Longer (9-in.) tube is connected between manifold barb "M" (machine) to barbed gas outlet fitting.
- Shorter (8-in.) tube is connected between manifold barb "P" (proximal) and barbed proximal pressure port.

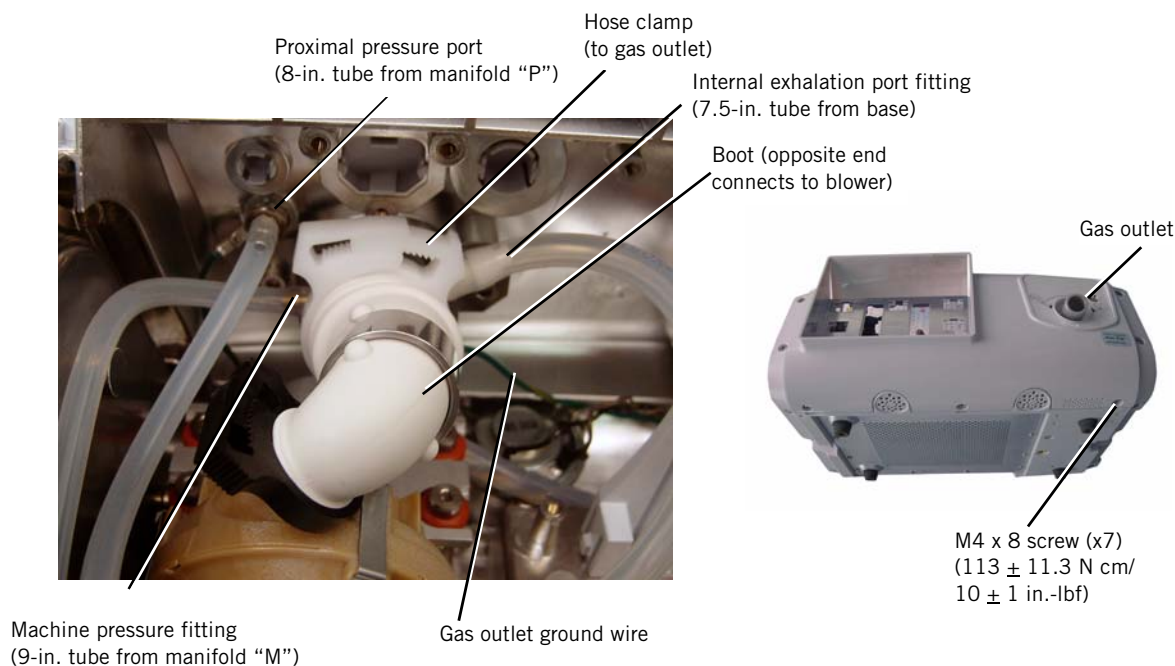

Figure 7-10: Removing the Front Panel

7.11 Gas Outlet Port

Follow these steps to remove the gas outlet port (Figure 7-11). Reverse to install.

1. Remove front panel (section 7.10).
2. Remove screws that attach Gas outlet bracket to inside front panel.

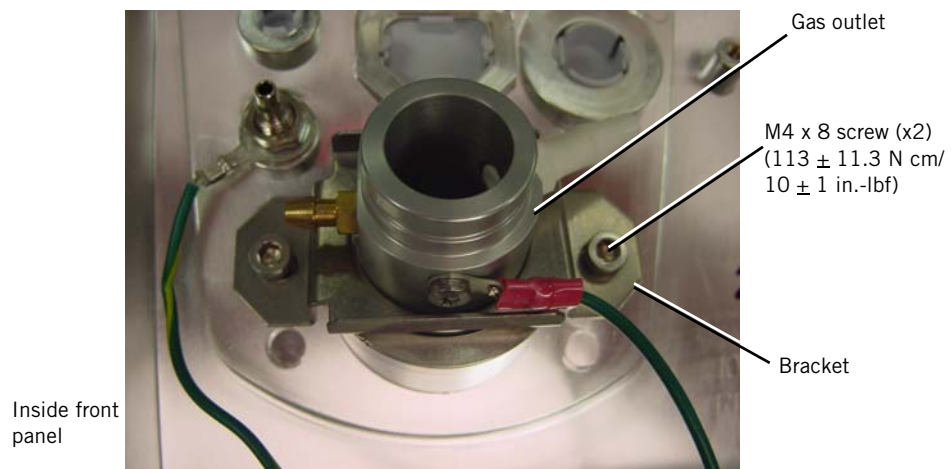

Figure 7-11: Removing the Gas Outlet

7.12 UI Retainer

Follow these steps to remove the UI retainer (Figure 7-12). Reverse to install.

1. Remove front panel (section 7.10).
2. Remove screws and washers that attach UI retainer to inside front panel.

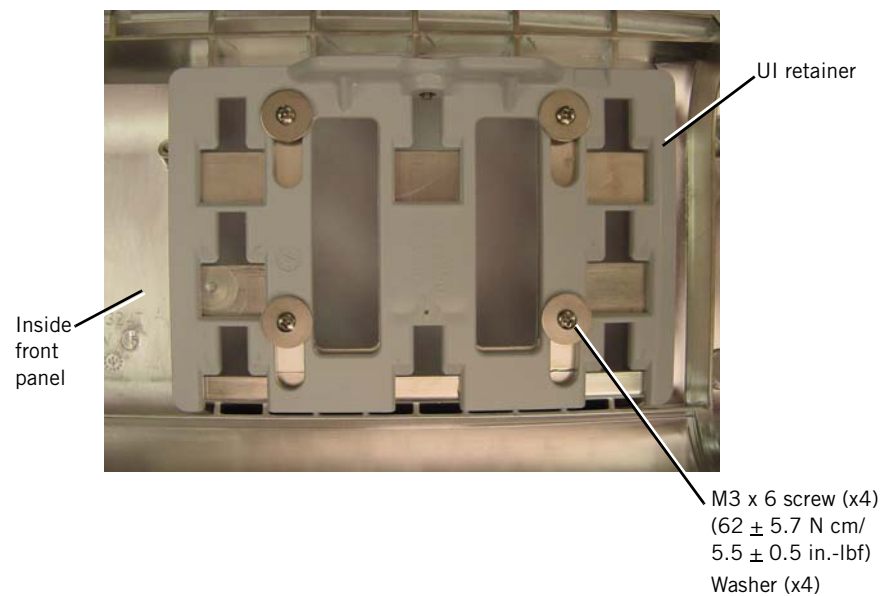

Figure 7-12: Removing the UI Retainer

7.13 Proximal Pressure Port

Follow these steps to remove the proximal pressure port (Figure 7-13). Reverse to install.

1. Remove front panel (section 7.10).
2. Remove the nut and lock washer that attach the proximal pressure port to the inside of the front panel. (Proximal pressure port includes the nut and lock washer.)

NOTE: When reinstalling the proximal pressure port, install the ground wire first, then the lock washer and nut.

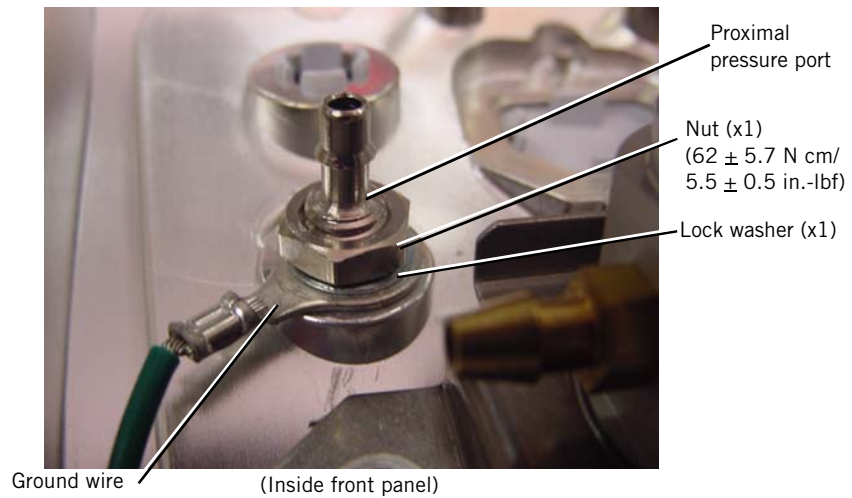

Figure 7-13: Removing the Proximal Pressure Port

7.14 Speakers

Follow these steps to remove the alarm speakers (Figure 7-14). Reverse to install.

1. Remove front panel (section 7.10).
2. Disconnect speaker #2 from the power management (PM) PCBA. (Speaker #1 is disconnected when the MC PCBA is disconnected.)
3. Remove the screw and washer that attaches each speaker to the base.

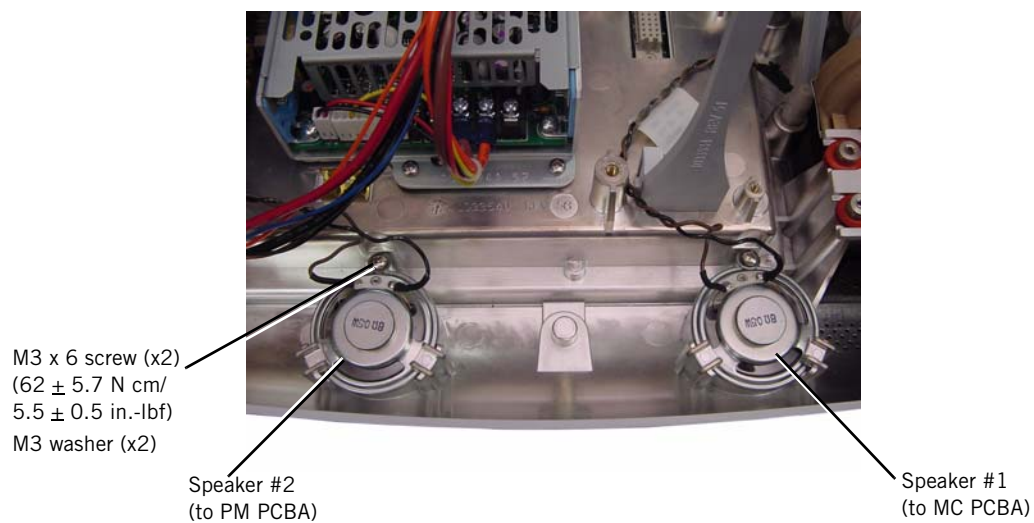

Figure 7-14: Removing the Alarm Speakers

7.15 Power Management (PM) PCBA

Follow these steps to remove the PM PCBA (Figure 7-15). Reverse to install.

1. Remove top cover (section 7.4).
2. Disconnect cables:
 - Speaker #2 cable
 - Power harness assembly
 - UI cable
 - LCD cable
3. Remove the screws that attach the PM PCBA to the left side wall.
4. Gently pull PM PCBA up from its connection on the CPU PCBA.

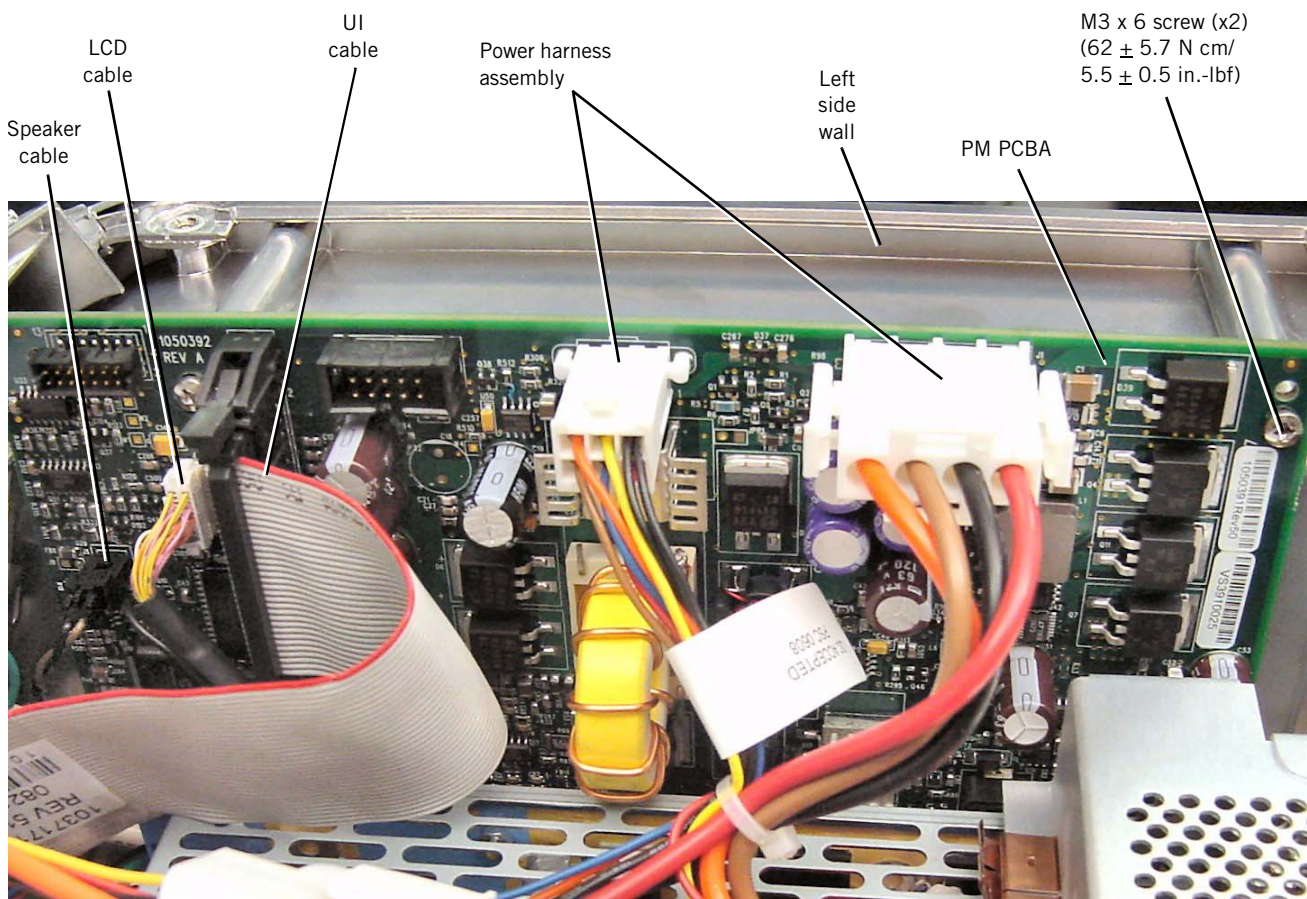

Figure 7-15: Removing the PM PCBA

7.16 Power Supply

Follow these steps to remove the power supply (Figure 7-16). Reverse to install.

NOTE: Do not remove any connections from the power supply terminal strip.

1. Remove MC PCBA (section 7.8) and PM PCBA (section 7.15).
2. Remove EMI shroud from power supply by slightly lifting the shroud away from the power supply with a small screwdriver.
3. Remove the screws that attach the mounting plate to the base. (Power supply includes attached mounting plate.)
4. Disconnect AC inlet cable and power harness.

NOTE: Squeeze EMI shroud before reinstalling to ensure that it fits snugly over the power supply.

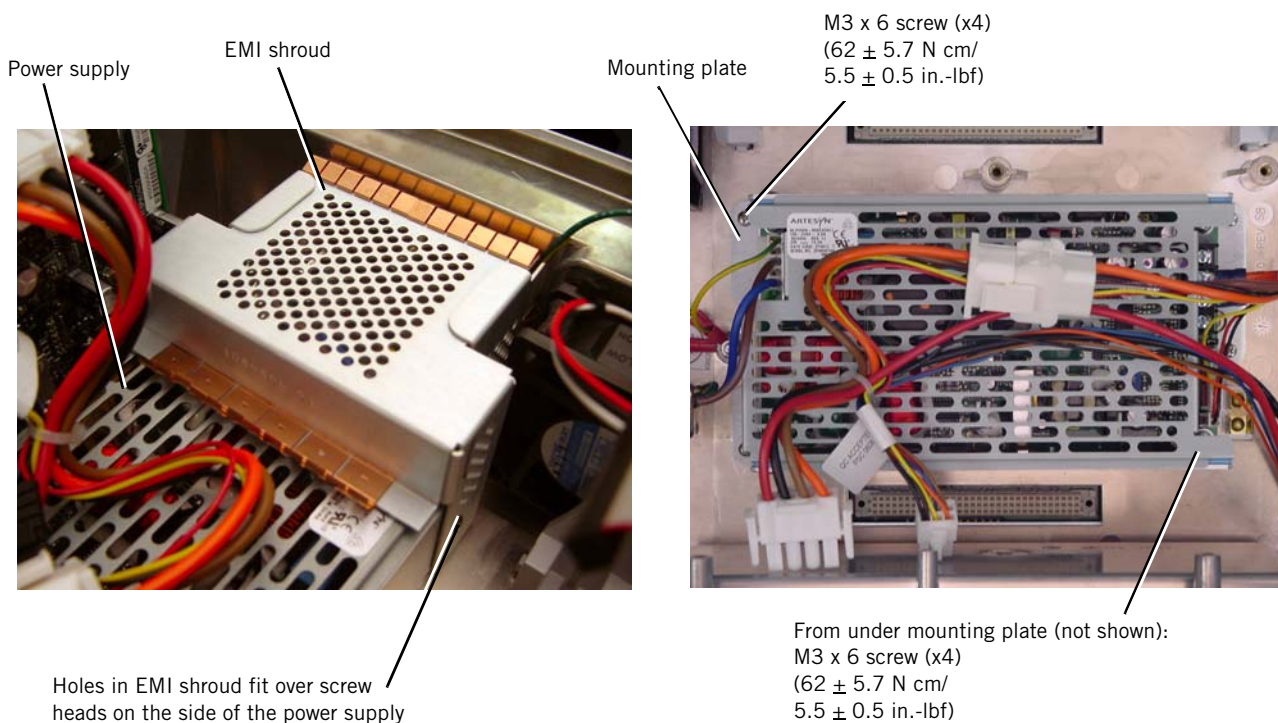

Figure 7-16: Removing the Power Supply

7.17 CPU PCBA

Follow these steps to remove the CPU PCBA (Figure 7-17). Reverse to install.

NOTE: Replacing the CPU PCBA deletes the serial number, installed options, significant event log entries, and ventilator preferences. Review the significant event log before removing the CPU PCBA.

- To reinstall options on a newly-installed CPU PCBA, please contact Customer Service at 800-345-6443 or 724-387-4000 for the appropriate option codes.
- You must provide this information to customer service: the V60 ventilator serial number and the CPU PCBA serial number.
- Option-only (no labeling or literature) part numbers:
 Ramp: P/N 1053080
 AVAPS: P/N 1053085
 C-FLEX: P/N 1053093

1. Remove MC PCBA (section 7.8) and PM PCBA (section 7.15).
2. Remove the screws that attach the CPU cover to the underside of the base.
3. Remove the screws that attach the CPU PCBA to the CPU tray.

NOTE: After installing a new CPU PCBA, reprogram the ventilator serial number and power-on hours as described in Chapter 6.

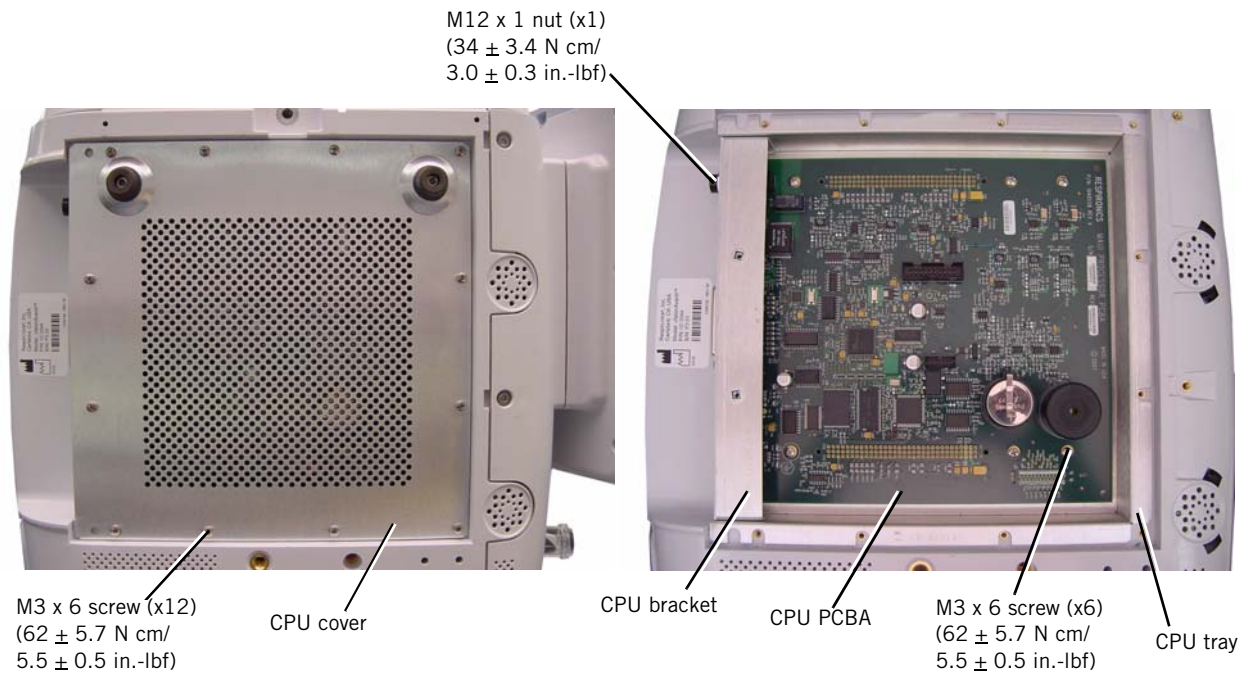

Figure 7-17: Removing the CPU PCBA

7.18 Real-Time Clock Battery

Follow these steps to remove the real-time clock battery (Figure 7-18). Reverse to install.

1. Disconnect all power (section 7.1).
2. Remove the screws that attach the CPU cover to the underside of the base.
3. Remove the real-time clock battery from the CPU PCBA.

NOTE: When installing the real-time clock battery, ensure that the positive side of the battery faces up.

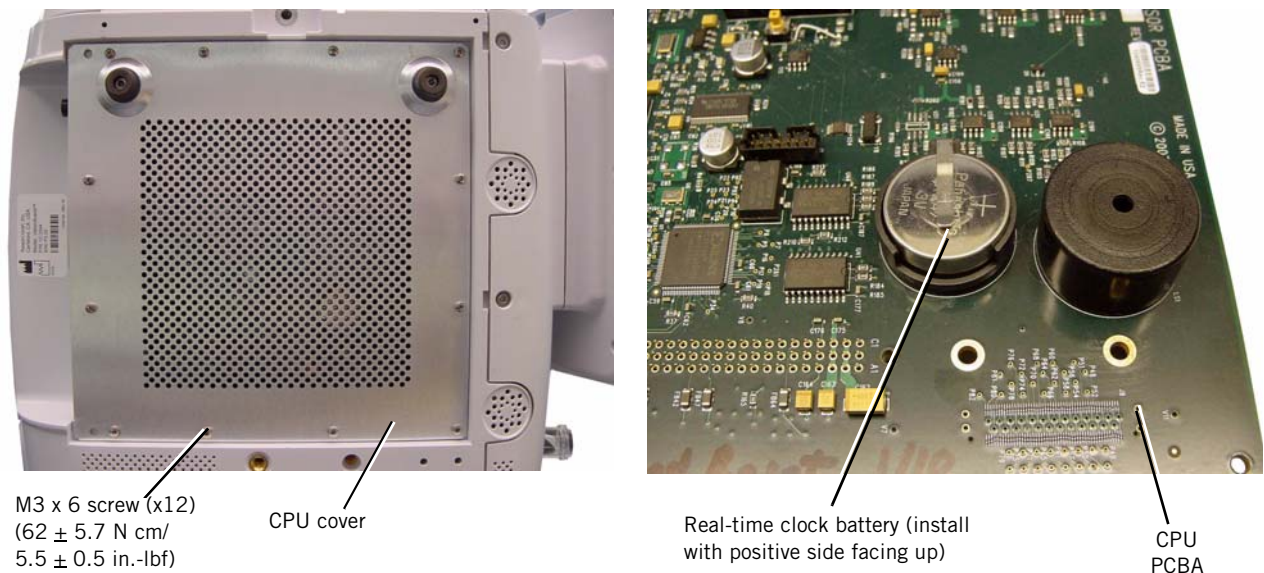

Figure 7-18: Removing the Real-Time Clock Battery

7.19 Left Side Wall

Follow these steps to remove the left side wall (Figure 7-19). Reverse to install.

1. Remove front panel (section 7.10).
2. Remove the battery (section 7.3).
3. Remove the PM PCBA (section 7.15).
4. Detach power harness assembly connector from left side wall.
5. Remove screws that attach the left side wall to the base.

NOTE: At reinstallation, install the power harness connector with its red wires toward the top of the side wall.

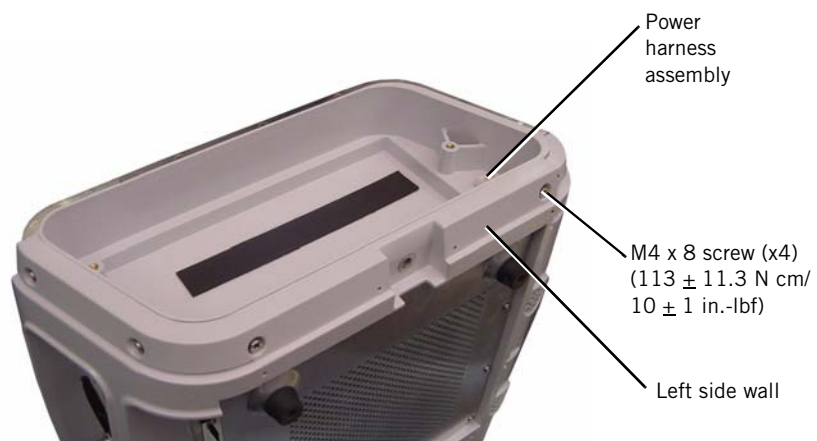

Figure 7-19: Removing the Left Side Wall

7.20 Gas Delivery Subsystem (GDS)

Follow these steps to remove the GDS (Figure 7-20, Figure 7-21). Reverse to install.

NOTE: The oxygen filter cap and air inlet collar attach the GDS to the ventilator, and when removed the GDS is not attached to the ventilator.

1. Remove top cover (section 7.4).
2. Remove the oxygen inlet (section 7.7).
3. Remove the screws that attach the filter retainer, then remove the filter retainer and air inlet filter.

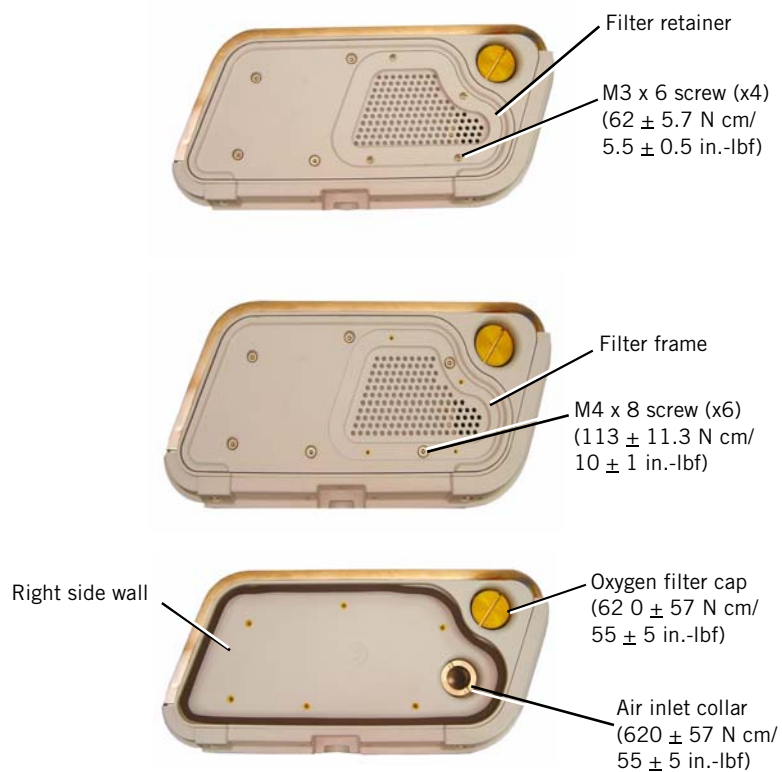

Figure 7-20: Removing the Air Inlet Filter and Retainer

4. Remove the screws that attach the filter frame, then remove filter frame.
5. Remove the tubing from the barbed fittings inside the front panel.
6. Loosen the hose clamp that attaches the boot to the manifold cap.

NOTE: When reinstalling, verify that the boot is attached to the blower before reinstalling the GDS.

Component Removal/Installation

7. Remove screw that attaches the ground cable to the manifold.
8. Remove the oxygen filter cap and air inlet collar from the right side wall.

NOTE: When reinstalling, apply a thin coat of Krytox to the inlet collar flange on the side wall. Tighten the air inlet collar first, and then the oxygen filter cap.

9. Disconnect the DA-MC cable from the DA PCBA.
10. Remove GDS from base.

NOTE: When reinstalling, connect tubing so that:

- Longer (9-in.) tube connects between manifold “M” (machine) barb and barbed gas outlet fitting.
- Shorter (8-in.) tube connects between manifold “P” (proximal) barb and barbed proximal pressure port.

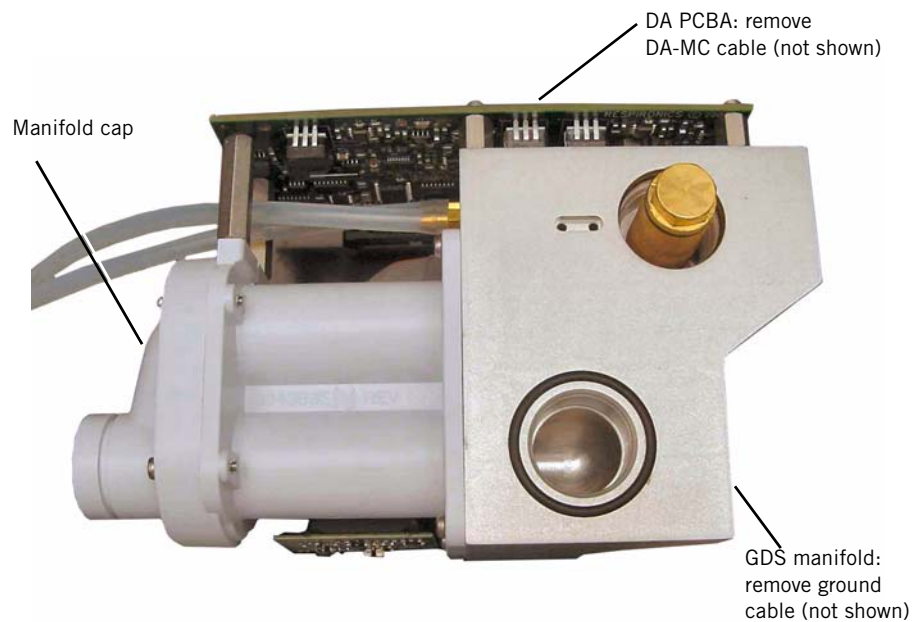

Figure 7-21: Removing the GDS

7.21 Right Side Wall

Follow these steps to remove the right side wall (Figure 7-22). Reverse to install.

1. Remove the front panel (section 7.10).
2. Remove the GDS (section 7.20).
3. Remove screws that attach the right side wall to the base.



Figure 7-22: Removing the Right Side Wall

7.22 Oxygen Inlet Filter

Follow these steps to remove the oxygen inlet filter (Figure 7-23). Reverse to install.

NOTE: When installing the oxygen inlet filter, ensure that the smaller end of the filter is opposite the threads in the GDS.

1. Remove GDS (section 7.20).
2. Use a wrench to loosen the oxygen inlet filter and remove from GDS.

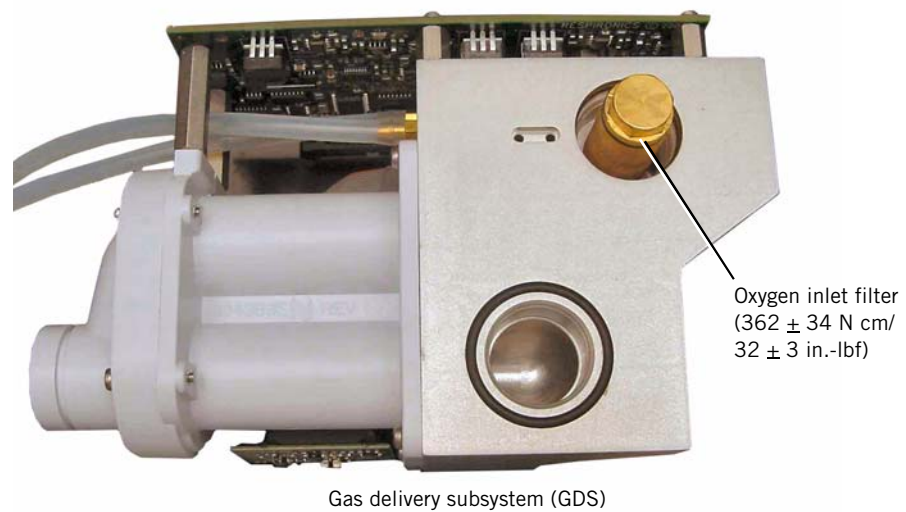

Figure 7-23: Removing the Oxygen Inlet Filter

7.23 Data Acquisition (DA) PCBA

Follow these steps to remove the DA PCBA (Figure 7-24). Reverse to install.

1. Remove GDS (section 7.20).
2. Remove the screws and washers that attach the DA PCBA to the manifold.
3. Disconnect these cables from the DA PCBA:
 - Oxygen solenoid cable
 - Flow sensor ribbon cable assembly
4. Remove the DA PCBA.

CAUTION: To avoid damage to the DA PCBA or solenoid pins, use care to avoid flexing the PCBA or bending the pins. When installing the DA PCBA, ensure that transducer grommets and o-rings are installed to the manifold as shown.

Component Removal/Installation

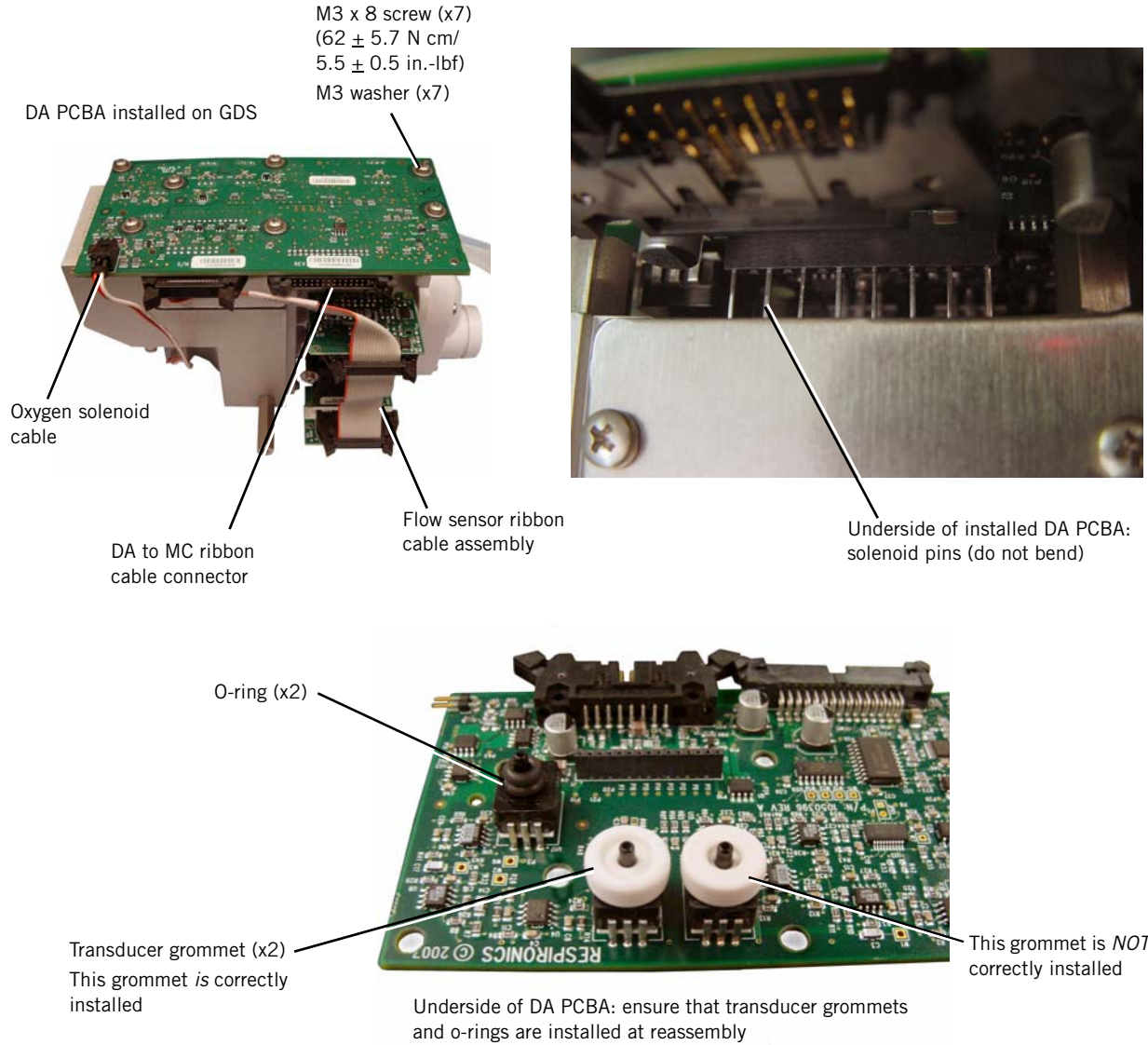

Figure 7-24: Removing the DA PCBA

7.24 Air and Oxygen Flow Sensor Assembly

Follow these steps to remove the air and oxygen flow sensor assembly (Figure 7-25). Reverse to install.

1. Remove GDS (section 7.20).
2. Disconnect the flow sensor cable from the DA PCBA and flow sensor assembly.
3. Remove the screws that attach the DA PCBA to the flow sensor assembly.
4. Remove screws that attach the flow sensor assembly to the manifold block.

NOTE: When installing a new flow sensor assembly, install the new o-rings.

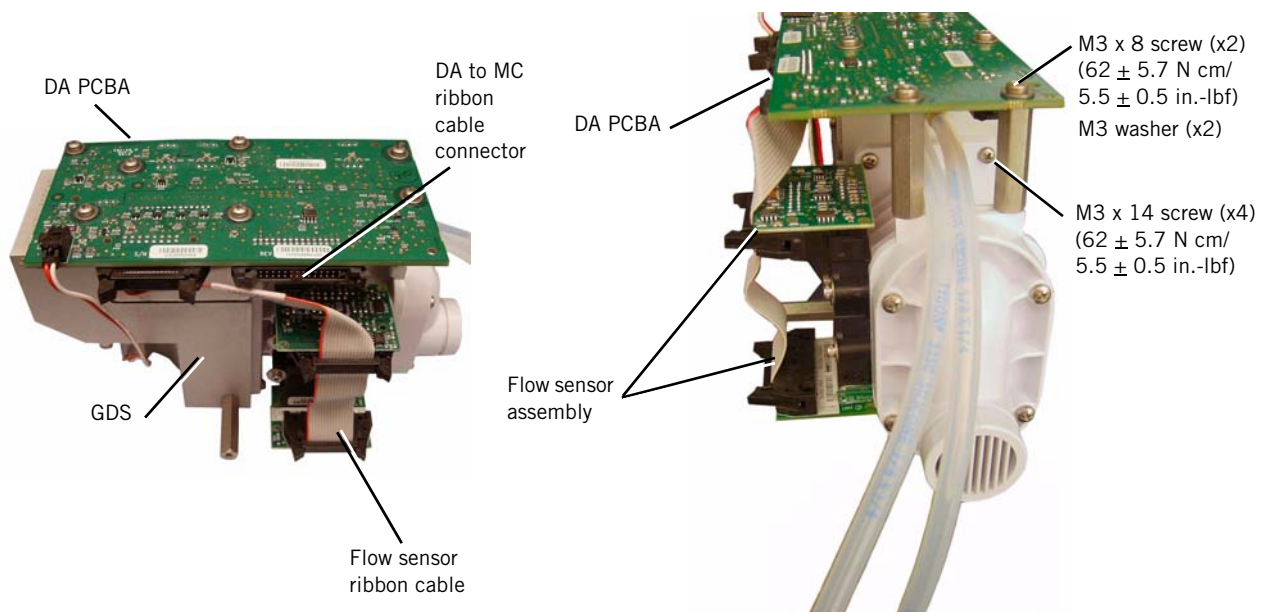

Figure 7-25: Removing the Flow Sensor Assembly

Component Removal/Installation

7.25 Oxygen Solenoid Valve

Follow these steps to remove the oxygen solenoid valve (Figure 7-26). Reverse to install.

1. Remove the GDS (section 7.20).
2. Disconnect the oxygen solenoid cable from the DA PCBA.
3. Remove the screws that attach the solenoid orientation clip to the solenoid mount.

NOTE: When installing the oxygen solenoid, apply a thin coat of Krytox on the o-rings.

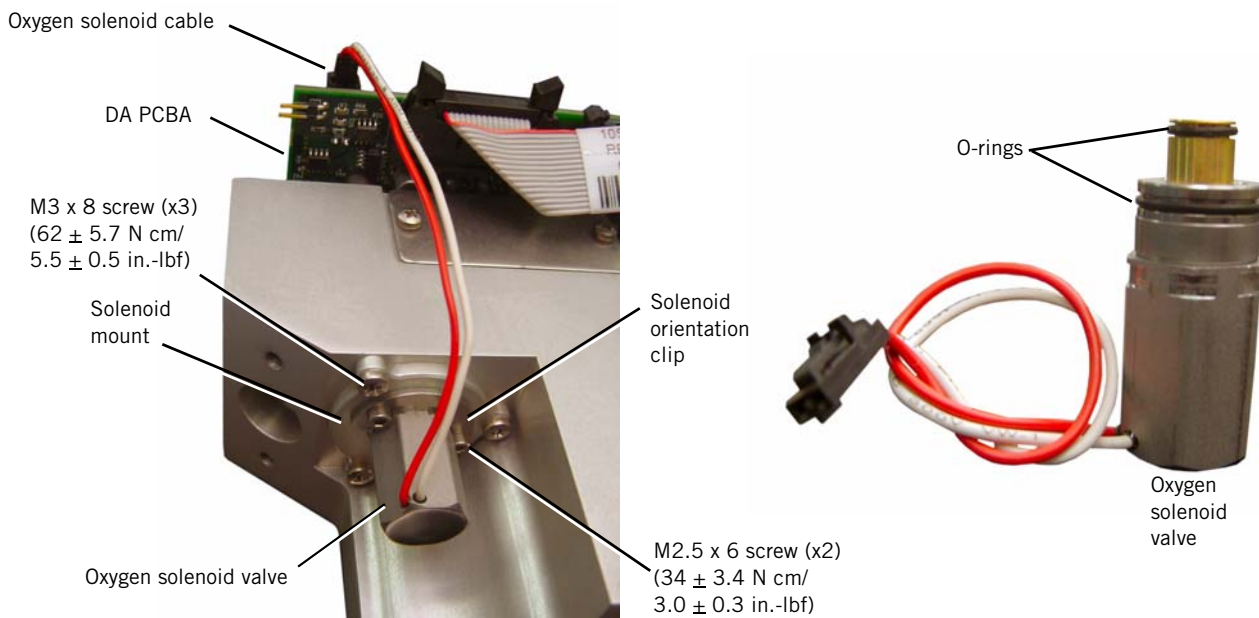

Figure 7-26: Removing the Oxygen Solenoid Valve

7.26 Solenoid Valves

Follow these steps to remove the solenoid valves (Figure 7-27). Reverse to install.

1. Remove the DA PCBA (section 7.23).
2. Remove the screws that attach the retention plate to the manifold.
3. When replacing the solenoid valves, ensure that the solenoid valve seals are properly installed to the manifold.

NOTE: When installing a new solenoid valve:

- Do not bend solenoid pins.
- Install a new solenoid valve seal.

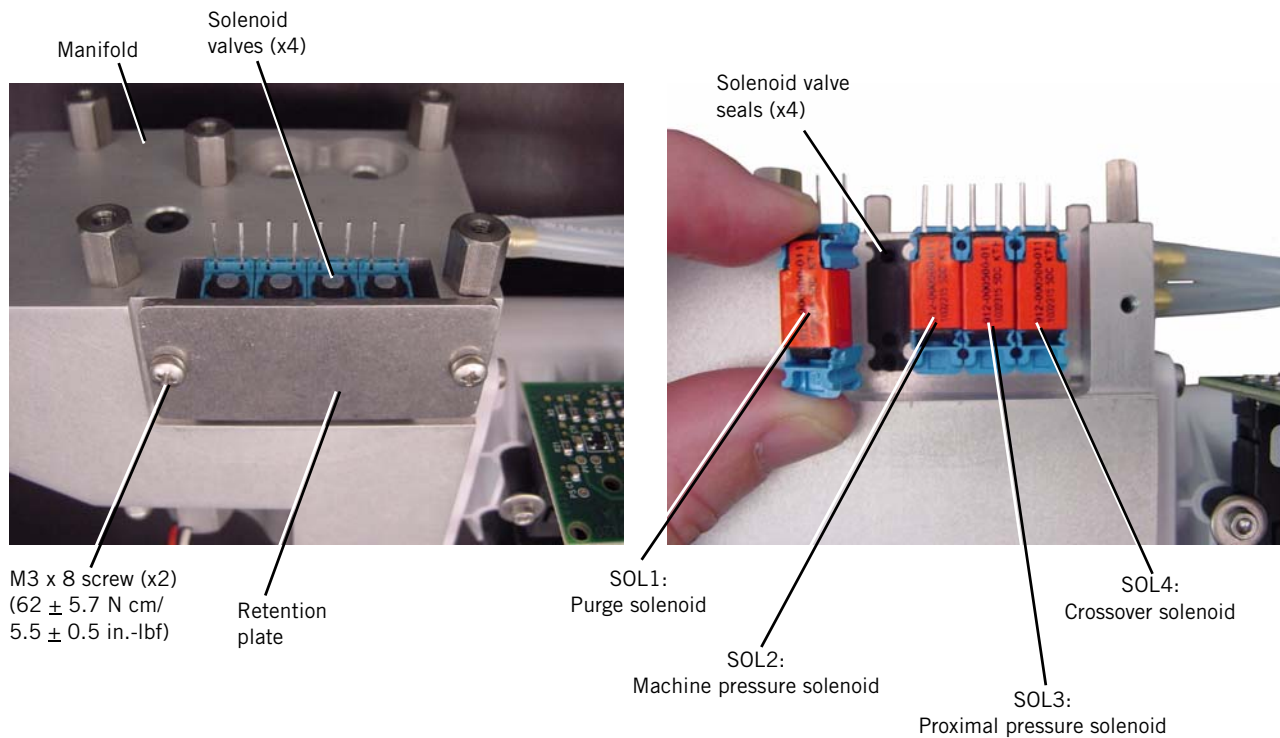

Figure 7-27: Removing the Solenoid Valves

7.27 Blower

Follow these steps to remove the blower (Figure 7-28). Reverse to install.

1. Remove the top cover (section 7.4).
2. Disconnect the blower cable from the MC PCBA.
3. Remove the boot and hose clamps that attach the blower to the gas outlet.
4. Remove the shoulder screws that attach the blower to the base.
5. Loosen the clamps on the boot that attaches the blower to the GDS, then remove the blower, boot, and clamps.

NOTE: When installing the blower:

- Ensure that the boot is fully and clamped to the blower before installing the blower.
- Install new motor mount grommets when installing a new blower.

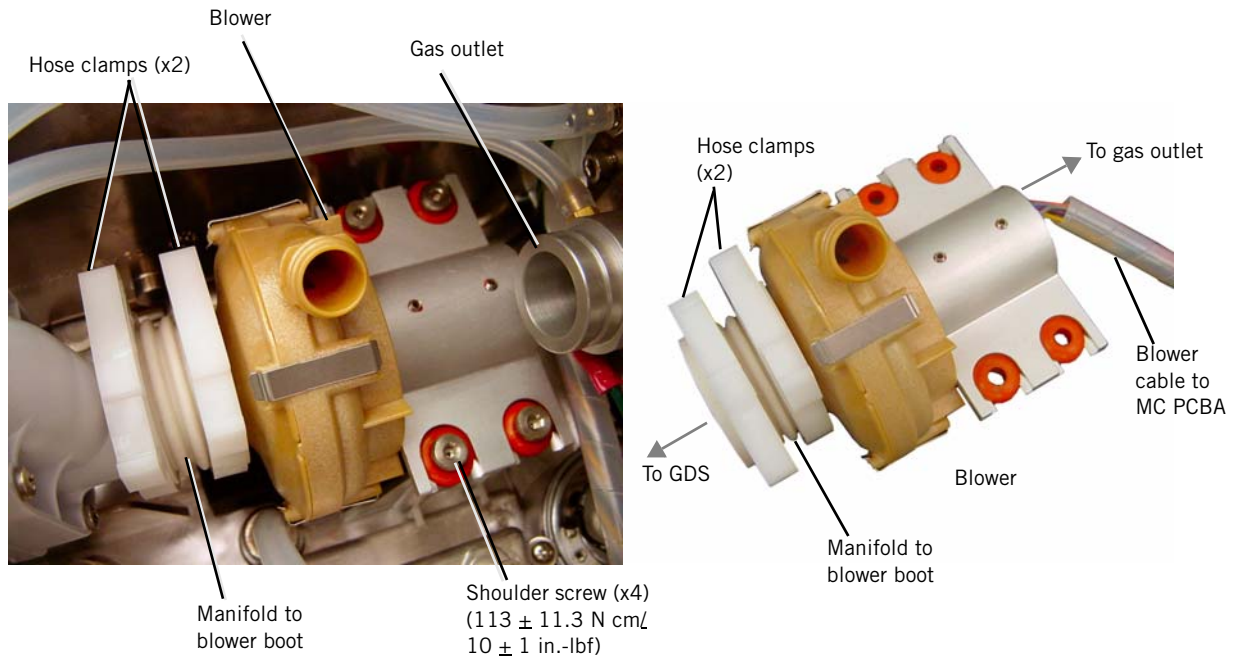

Figure 7-28: Removing the Blower

7.28 Opening the User Interface (UI)/Rear Bezel

Follow these steps to open the UI and remove the rear bezel (Figure 7-29). Reverse to install.

1. Separate UI from base (section 7.9).
2. Remove the screws from the end cap and remove the end cap.
3. Remove the screws from the rear bezel.
4. Separate the front and rear bezel.

NOTE:

When reinstalling rear bezel:

- Ensure that gasket is properly installed around the inside of the bezel.
- Verify that all cables extend through the same slot as shown.

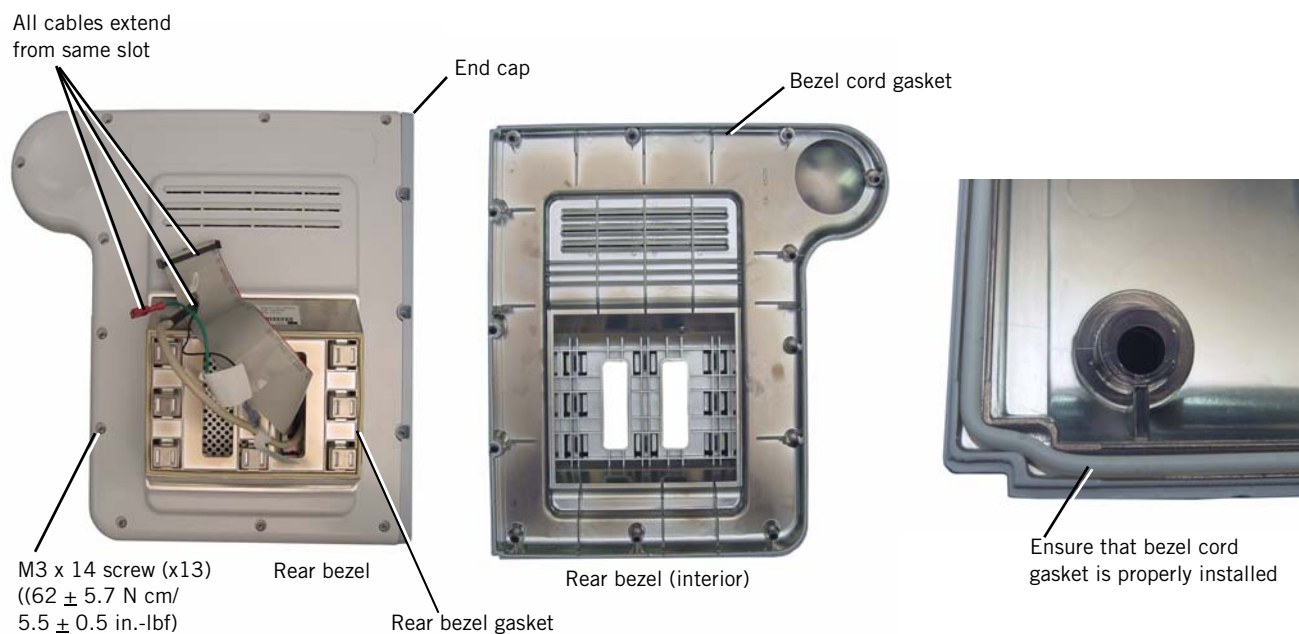

Figure 7-29: Opening the UI

7.29 Power Switch Overlay

Follow these steps to remove the power switch overlay (Figure 7-30). Reverse to install.

1. Open the UI (section 7.28).
2. From inside the front bezel, disconnect the power switch overlay cable from the UI PCBA.
3. Carefully peel the power switch overlay from the front bezel.
4. Once the power switch overlay is removed, use isopropyl alcohol to remove any remaining adhesive. Ensure that the bezel surface is clean and dry.

CAUTION: Do not flex the overlay.

NOTE: When installing a new power switch overlay, peel the backing from the overlay, feed the cable through the bezel cutout, align the overlay to the front bezel, and press to adhere.



Power switch overlay position on front bezel

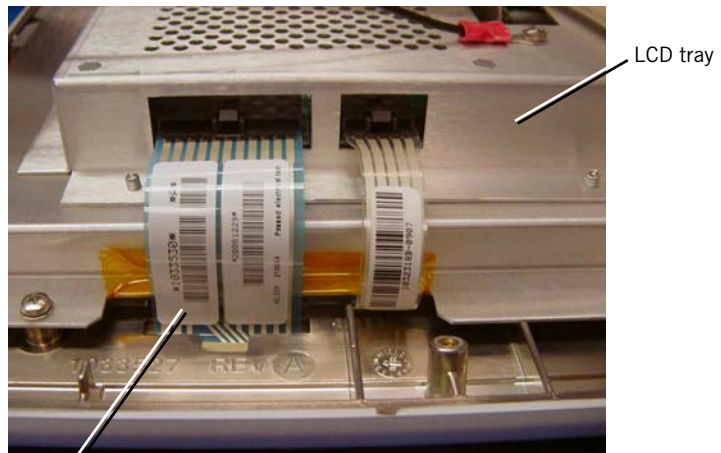

Power switch overlay cable

Figure 7-30: Removing the Power Switch Overlay

7.30 Switch PCBA

Follow these steps to remove the switch PCBA (Figure 7-31). Reverse to install.

1. Open the UI (section 7.28).
2. Remove the screws that attach the switch PCBA to the inside of the front bezel.
3. Disconnect the nav-ring and UI PCBA cables from the switch PCBA.

NOTE: During installation, verify that the nav-ring cable is fully seated into its connector on the switch PCBA.

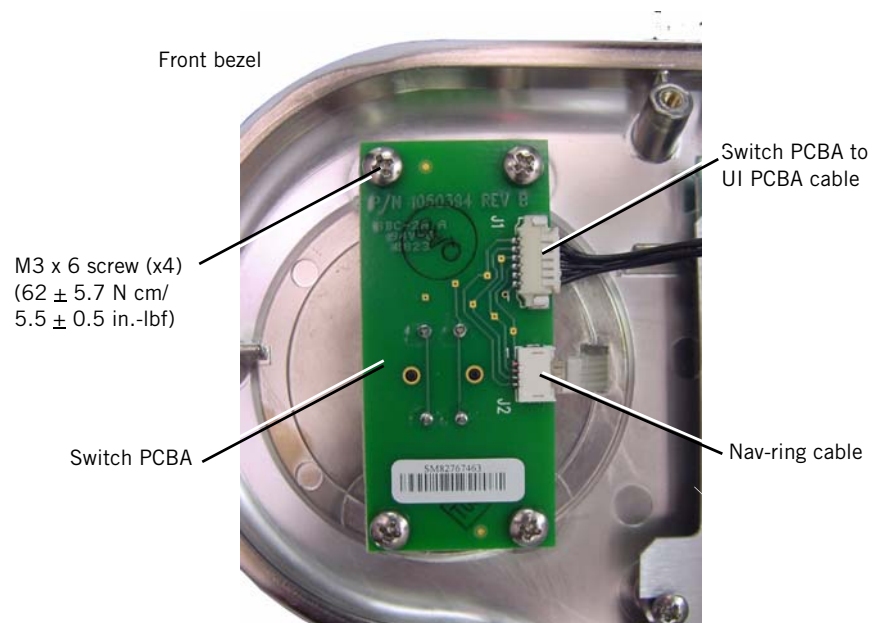

Figure 7-31: Removing the Switch PCBA

7.31 Nav-Ring Assembly

Follow these steps to remove the nav-ring assembly (Figure 7-32). Reverse to install.

1. Remove the switch PCBA (section 7.30).
2. Remove the nav-ring button from the front of the bezel.
3. Carefully remove the nav-ring assembly from the front of the bezel. Use isopropyl alcohol to remove any remaining adhesive. Ensure that the surface is clean and dry.

NOTE: After installing the nav-ring assembly, install the button so that its check mark is upright as shown.



Figure 7-32: Nav-Ring Assembly Button

7.32 Front Bezel, Touch Screen

Follow these steps to remove the front bezel and touch screen (Figure 7-33). Reverse to install.

NOTE: When installing a new touch screen, remove the protective film and avoid touching the screen surface.

NOTE: After installing a new UI assembly, perform the touch screen calibration (section 5.3).

1. Open the UI (section 7.28).
2. Disconnect these cables from the UI PCBA:
 - Switch PCBA cable
 - Nav-ring cable
 - Power switch overlay cable
 - Touch screen cable
3. Remove the switch PCBA.
4. Remove the screw that attaches the cable clamp to the LCD tray.
5. Remove the screws and washers that attach the LCD tray to the front bezel, then remove the LCD tray.
6. Remove the touch screen from the front bezel.

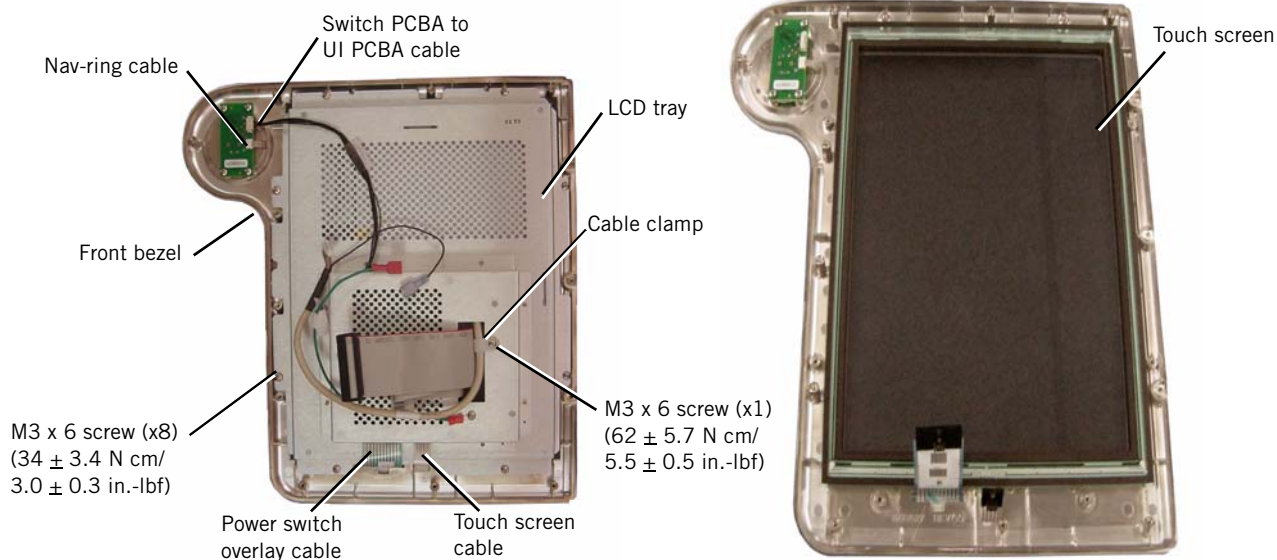

Figure 7-33: Removing the Touch Screen

7.33 LCD

Follow these steps to remove the LCD (Figure 7-34). Reverse to install.

NOTE: When installing a new LCD, remove the protective film before reinstalling the LCD tray to the front bezel, and avoid touching the LCD screen.

1. Open and separate the UI bezel (section 7.28).
2. Remove the front bezel (section 7.32).
3. Remove the screws that attach the LCD to the LCD tray.
4. With the LCD face up, carefully lift the LCD slightly to disconnect the backlight inverter and LCD cable.
5. Remove the LCD.

NOTE: When installing the LCD cable to the LCD, use a new piece of Kapton tape.

Component Removal/Installation

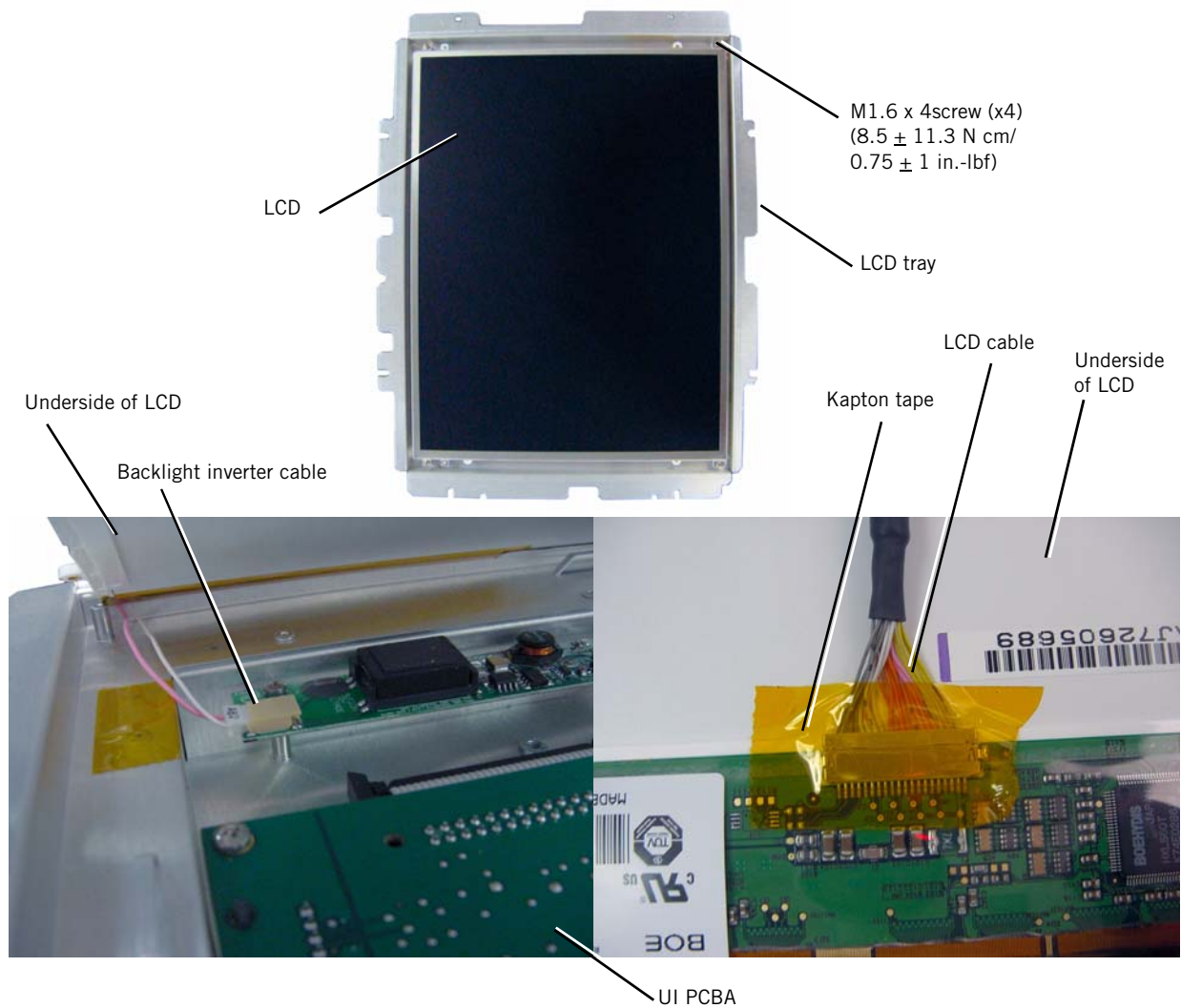

Figure 7-34: Removing the LCD

7.34 User Interface (UI) PCBA

Follow these steps to remove the UI PCBA (Figure 7-35). Reverse to install.

1. Remove the LCD (section 7.33).
2. Remove the screws that attach the UI PCBA to the LCD tray.
3. Disconnect these cables from the UI PCBA:
 - Backlight inverter cable
 - UI ribbon cable

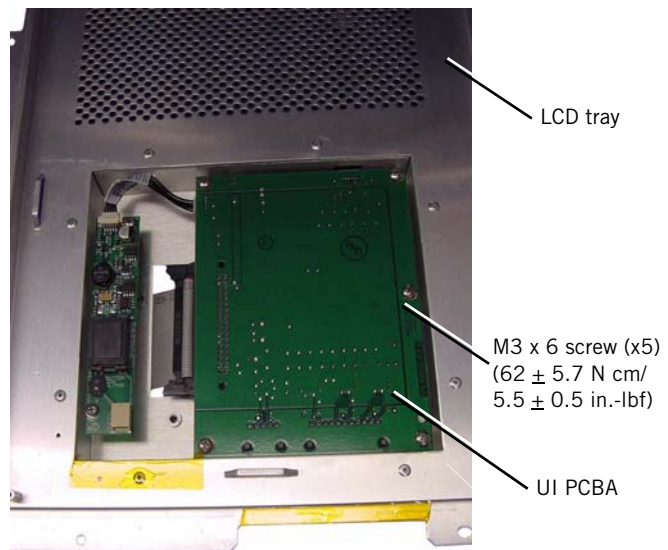

Figure 7-35: Removing the UI PCBA

7.35 Backlight Inverter PCBA

Follow these steps to remove the backlight inverter PCBA (Figure 7-36). Reverse to install.

1. Remove the LCD (section 7.33).
2. Remove the screws that attach the backlight inverter PCBA to the LCD tray.
3. Disconnect the backlight inverter cable from the backlight inverter PCBA.

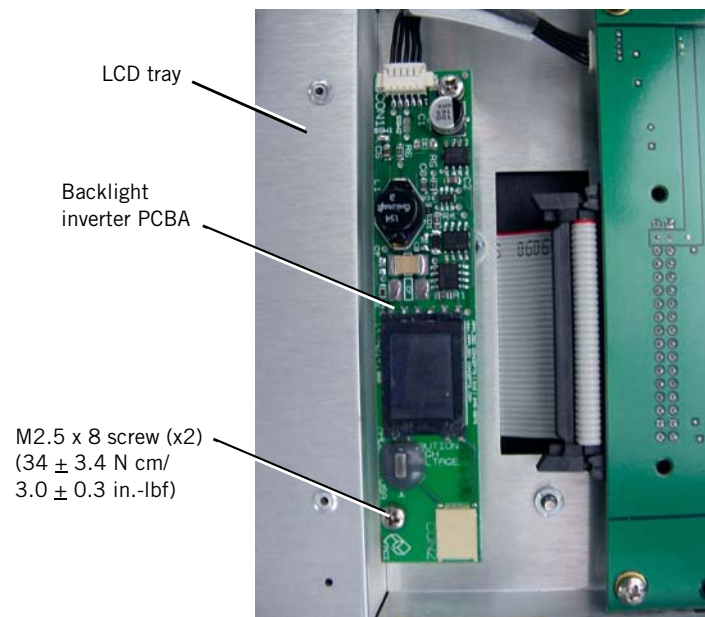

Figure 7-36: Removing the Backlight Inverter PCBA

7.36 LCD Tray Follow these steps to remove the LCD tray (Figure 7-37). Reverse to install.

1. Remove the UI PCBA (section 7.34).
2. Remove the backlight inverter PCBA (section 7.35).

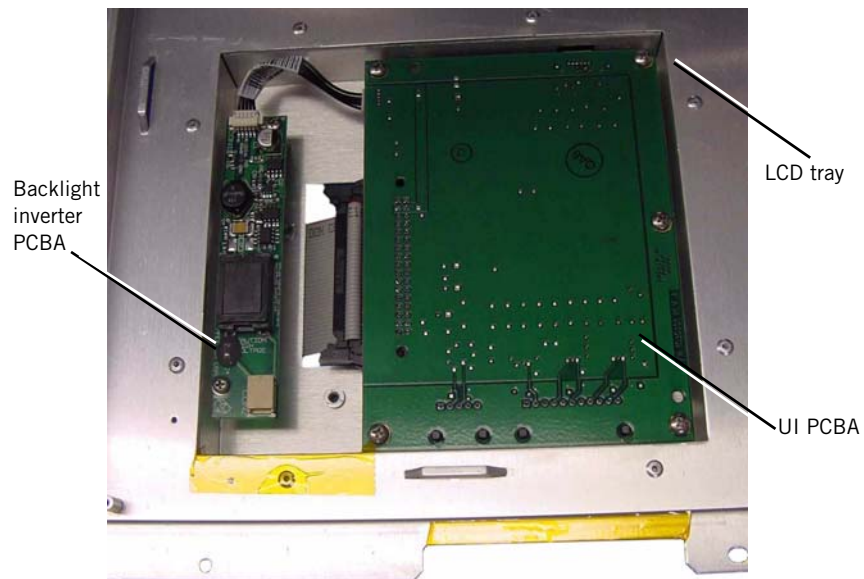

Figure 7-37: Removing the LCD Tray

7.37 Bottom Feet

Follow these steps to remove the bottom feet (section Figure 7-38:). Reverse to install.

CAUTION: Follow these instructions to remove the right rear bottom foot: it is attached with a hex nut inside the base assembly.

1. Remove the 3 screws that attach the front and left rear bottom feet to the base assembly.
2. Disconnect all power (section 7.1).
3. Remove the GDS (section 7.20).
4. From inside the base assembly, remove the hex nut that attaches the screw and bottom foot.

M4 hex kep nut (x1)
(113 ± 11.3 N cm/
 10 ± 1 in.-lbf)

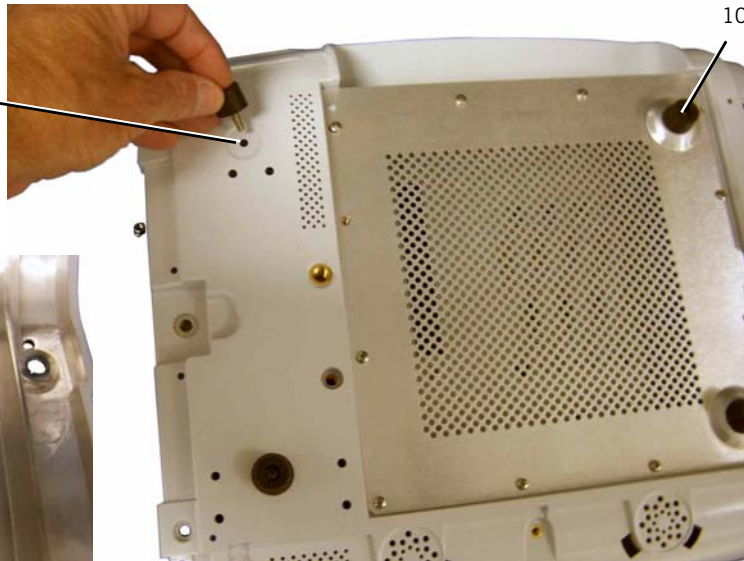
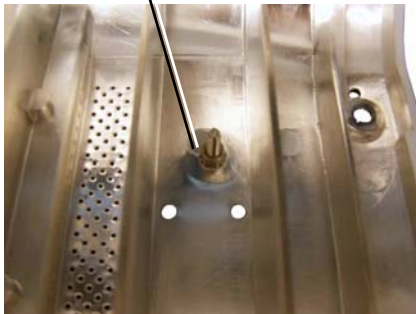

M4 x 14 screw (x4)
(113 ± 11.3 N cm/
 10 ± 1 in.-lbf)

Figure 7-38: Removing the Bottom Feet

7.38 Labels

Follow these steps to remove and replace labels (Figure 7-39, Figure 7-40, Figure 7-41, Figure 7-42):

1. Use isopropyl alcohol to remove any remaining adhesive from the original part. Ensure that surface is clean and dry.
2. Peel backing from new part and press to adhere.



Figure 7-39: Labels: Front of UI

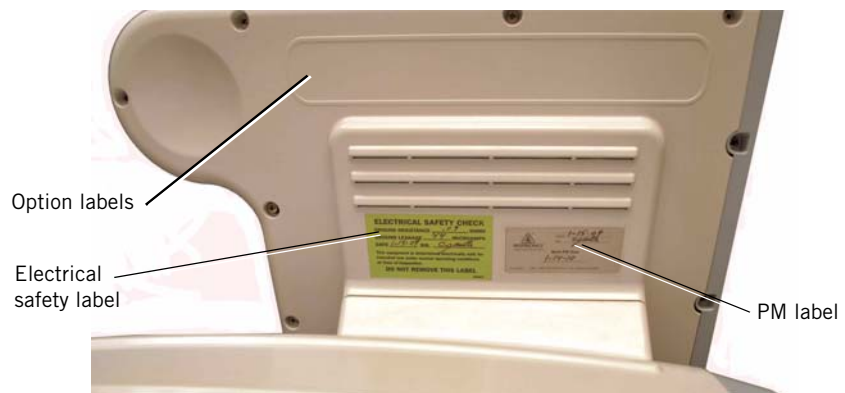

Figure 7-40: Labels: Back of UI

Component Removal/Installation

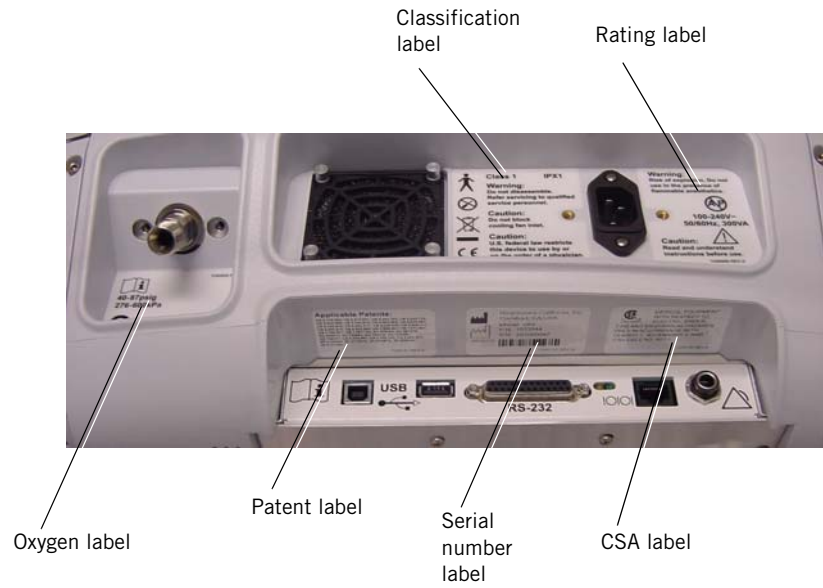

Figure 7-41: Labels: Back Panel of Base

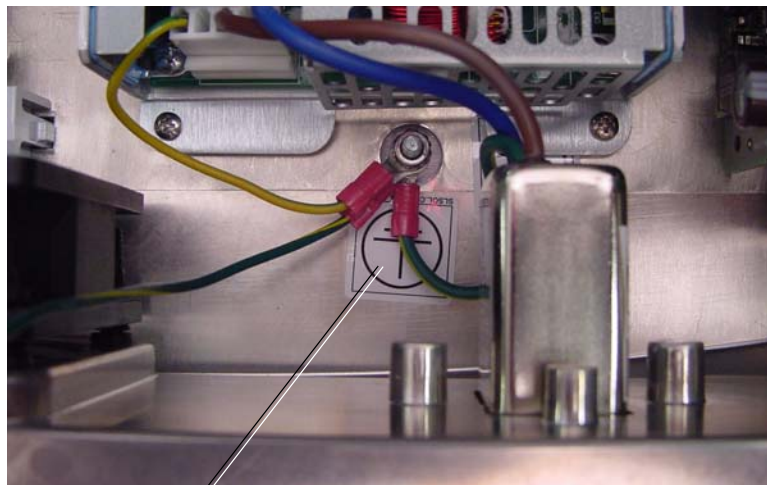

Figure 7-42: Protective Earth Ground Label (inside base assembly)

(This page is intentionally blank.)

Chapter 8. Performance Verification

Performance verification verifies the integrity of the sensors and other critical components in the ventilator using external measurement devices. The performance verification consists of several tests (Table 8-1). The type of service performed determines which tests are required (Table 8-2). Run all tests in order.

CAUTION: Performance verification is to be performed only by a qualified service technician.

Table 8-1: Performance Verification Tests

Test number	Description
1	Electrical safety
2	Leak tests
3	Ventilator controls
4	Pressure accuracy
5	Air delivery/flow accuracy*
6	Oxygen flow accuracy*
7	Oxygen accuracy
8	S/T performance
9	Alarms
10	Power fail
11	Internal battery
* Flow testing above 1951 m (6400 ft.) cannot attain 130 SLPM.	

Performance Verification

Table 8-2: Performance Verification Test Requirements

Service performed	Required tests
Annual preventive maintenance	All
AC inlet: removal/replacement	Electrical safety
Air and oxygen flow sensor assembly: removal/replacement	Electrical safety High pressure leak test System leak test Pressure accuracy Air delivery/flow accuracy Oxygen flow accuracy Oxygen accuracy Breath rate
Backlight inverter cable: removal/replacement	Electrical safety Ventilator controls
Backlight inverter PCBA: removal/replacement	Electrical safety Ventilator controls
Blower: removal/replacement	Electrical safety System leak test Pressure accuracy Air delivery/flow accuracy
CPU PCBA: removal/replacement	Electrical safety Alarms
Data acquisition (DA) PCBA: removal/replacement	Electrical safety High pressure leak test System leak test Pressure accuracy Air delivery/flow accuracy Oxygen flow accuracy Oxygen accuracy Breath rate
Data acquisition (DA) PCBA to flow sensors cable: removal/replacement	Electrical safety
Data acquisition (DA) PCBA to motor controller (MC) PCBA cable: removal/replacement	Electrical safety
Fan: removal/replacement	Electrical safety

Performance Verification

Table 8-2: Performance Verification Test Requirements

Service performed	Required tests
Gas delivery subsystem (GDS): removal/replacement	Electrical safety High pressure leak test System leak test Pressure accuracy Air delivery/flow accuracy Oxygen flow accuracy Oxygen accuracy Breath rate
Gas outlet port: removal/replacement	Electrical safety System leak test Pressure accuracy
Internal battery: removal/replacement	Electrical safety Internal battery
LCD: removal/replacement	Electrical safety Ventilator controls
LCD cable: removal/replacement	Electrical safety Ventilator controls
Motor controller (MC) PCBA: removal/replacement	Electrical safety Air delivery/flow accuracy Internal battery Power fail
Nav-ring: removal/replacement	Electrical safety Ventilator controls
Oxygen inlet filter: removal/replacement	Electrical safety High pressure leak test System leak test Pressure accuracy Oxygen flow accuracy Oxygen accuracy
Oxygen valve: removal/replacement	Electrical safety High pressure leak test System leak test Pressure accuracy Oxygen flow accuracy Oxygen accuracy Breath rate
Power harness cable: removal/replacement	Electrical safety Internal battery
Power management (PM) PCBA: removal/replacement	Electrical safety Internal battery
Power supply: removal/replacement	Electrical safety

Table 8-2: Performance Verification Test Requirements

Service performed	Required tests
Power switch overlay: removal/replacement	Electrical safety
Rubber boots: removal/replacement/adjustment	Electrical safety System leak test Pressure accuracy
Solenoid valve: removal/replacement	Electrical safety High pressure leak test System leak test Pressure accuracy Air delivery/flow accuracy Oxygen flow accuracy Oxygen accuracy Breath rate
Speaker: removal/replacement	Electrical safety Alarms
Switch PCBA: removal/replacement	Electrical safety Ventilator controls
Touch screen: removal/replacement	Electrical safety Touch screen calibration Ventilator controls
User interface (UI) PCBA: removal/replacement	Electrical safety Ventilator controls
User interface: removal/replacement	Electrical safety Ventilator controls
UI PCBA to power management (PM) PCBA cable: removal/replacement	Electrical safety Ventilator controls

8.1 Required Test Equipment

Table 8-3 summarizes the test equipment required, and Table 8-4 summarizes the service accessories required for performance verification. Check the calibration status of all test equipment before use.

Table 8-3: Required Test Equipment for Performance Verification

Description	Recommended Manufacturer/Model
Electrical safety analyzer	Dale LT 5440 or equivalent
Pneumatic calibration analyzer(s) capable of measuring low pressure (cmH ₂ O), flow rate (LPM), volume (liters), and respiratory rate	TSI Certifier FA Plus (P/N 1040311), or equivalent
Oxygen analyzer	TSI Certifier FA Plus or equivalent
Pressure analyzer capable of measuring high pressure (PSI)	TSI Certifier FA Plus or equivalent
Digital multimeter (DMM) and frequency counter	Local supplier
Test lung	IngMar QuickLung or equivalent
Temperature/humidity monitor	Fisher Scientific 11-661-14 or equivalent
NOTE:	An oxygen source capable of delivering 140 LPM (40-87 PSI) is required for oxygen system tests.

Table 8-4: Required Service Accessories for Performance Verification

Description	Part Number
V60 Service Kit, which includes:	1054291
Adapter, 22-mm OD, both ends	1002505
Adapter, 25-pin to 9-pin	1058403
Adapter, torque, cap/collar	1056005
BiPAP test adapter, 0.25-in.	332353
Cable, null modem	1022815
Cable, TTL communications	1058778
Circuit tube, 18-in. smooth-bore (qty. 2)	1000060
Coupling, straight, silicone	500-1000-43
Forceps, locking, red plastic	1058430
Plug, low-pressure	1058270
Plug, tapered $^{23}/_{32}$ - $^{61}/_{64}$ in., silicone (qty. 2)	1055322
Plug, tapered $^{9}/_{16}$ - $^{3}/_{4}$ in., silicone	1055323
Pressure pick-off port (oxygen enrichment attachment SNGL)	312710
Proximal pressure line tubing	312114
Remote alarm test cable	1027818
Remote alarm test cable adapter	1027817
Syringe, system leak test	1058271
Valve, ball	1058431
Valve, oxygen/regulator shut-off	1058380
Whisper Swivel II	332113

8.2 Preliminary Cleaning, Inspection and Setup

WARNING: To prevent disease transmission, use protective equipment when handling contaminated bacteria filters or other patient accessories.

Before servicing the ventilator, clean and inspect as follows:

- Clean the ventilator exterior as described in the *User Manual*.
- Remove the humidifier from the ventilator, if applicable.
- Visually inspect the exterior of the ventilator for damage. Replace damaged parts as needed.
- Remove and inspect the cooling fan filter and air inlet filter. Clean or replace filter as described in the *User Manual*.

8.3 View and Record Ventilator Information

1. If the ventilator is not already in diagnostic mode, press and hold the nav-ring **Enter** button, and press the **On/Shutdown** button on the user interface. Within 5 seconds of power up, release and press the nav-ring **Enter** button again to enter the Diagnostics menu.
2. Touch **Service** to display the Ventilator Information screen (Figure 8-1), and record the following information on the Electrical Safety (section 8.8, *Electrical Safety Data Form*) or Performance Verification Data Form (section 8.9, *Performance Verification Data Form*):
 - Software options
 - Ventilator serial number
 - Software version
 - Total power-on hours
 - Hours since last PM
 - Battery lot number
 - Battery manufacture date

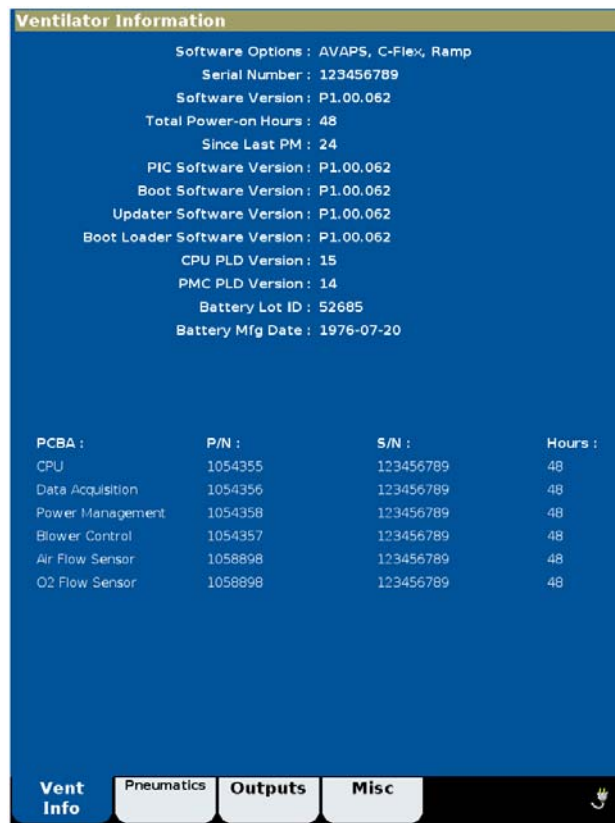

Figure 8-1: Ventilator Information Screen

3. Touch **Pneumatics** and record the displayed barometric pressure.
4. Measure and record the ambient temperature and relative humidity.
5. Complete a diagnostic report (DRPTA) download (Chapter 6).
6. Turn the ventilator OFF.

8.4 Pneumatic Calibration Analyzer Setup

Follow these steps to set up the Certifier FA Plus pneumatic calibration analyzer, including:

- Measurement Selection Screen
- Averaging Setup Menu
- Trigger Options menu
- Configurations menu

NOTE: When using a pneumatic calibration analyzer, remember the analyzer should be in STP when measuring flow.

8.4.1 Measurement Selection Screen

Use the Measurement Selection Screen to add or remove parameters from the Certifier FA Plus screen.

1. Touch any parameter on the analyzer touch screen to display the Measurement Selection Screen (Figure 8-2).

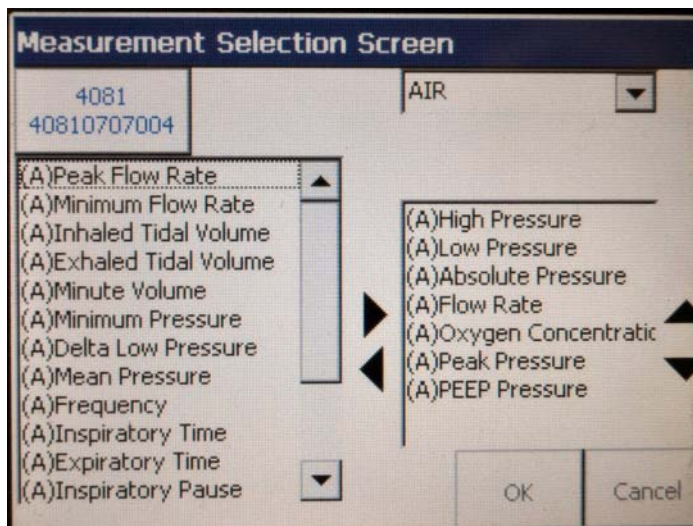

Figure 8-2: Measurement Selection Screen (Certifier FA Plus)

2. To add a parameter, touch the parameter name in the left window then touch the right arrow.
To remove a parameter, touch the parameter name in the right window then touch the left arrow.
Use the up and down arrows to determine the order of the selected parameters.
Recommended parameters:
 - High Pressure (psig)

Performance Verification

- Low Pressure (cmH₂O)
 - Absolute Pressure (mmHg)
 - Flow Rate (SLPM)
 - Oxygen Concentration (%)
 - Peak Pressure (cmH₂O)
 - PEEP Pressure (cmH₂O)
3. To select or change the measured gas, touch the gas dropdown list and select the gas.
 4. Touch **OK** when parameters selection and order is complete.

8.4.2 Averaging Setup Menu

Use the Averaging Setup Menu to select averages for breath parameters (how many breaths are averaged) and real-time transducer values (the time interval used for averaging).

1. Touch the **Breath Average** button to display the Averaging Setup Menu (Figure 8-3).

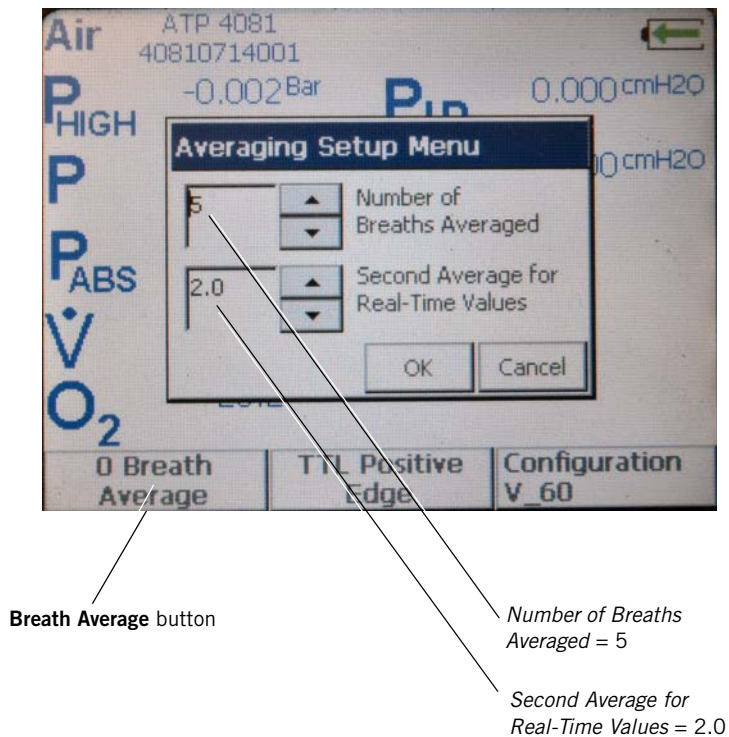

Figure 8-3: Averaging Setup Menu (Certifier FA Plus)

2. Use the up and down arrows to set these values:
Number of Breaths Averaged: 5.
Second Average for Real-Time Values: 2.0.
3. Touch **OK** when complete.

8.4.3 Trigger Options

Use Trigger Options to define how the analyzer detects the start of the inspiratory and expiratory breath cycles.

1. Touch the Trigger options button to display the Trigger Options menu (Figure 8-4).

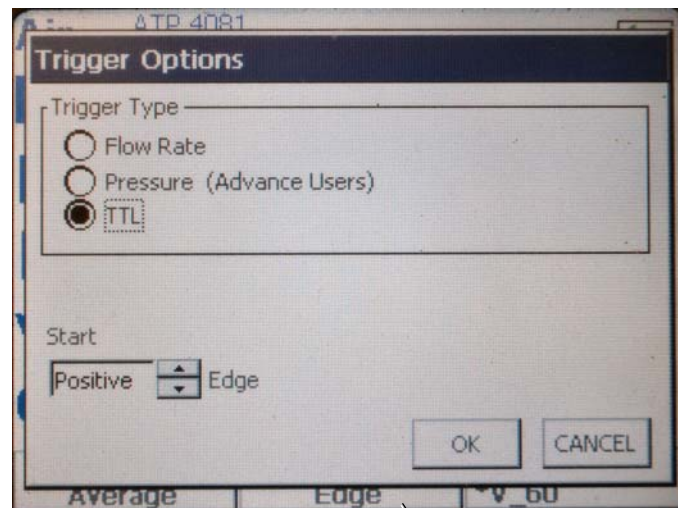

Trigger options button

Figure 8-4: Trigger Options Menu (Certifier FA Plus)

2. Select **TTL**.
3. Use the arrow buttons to select **Start Trigger**.
4. Touch **OK** when complete.

8.4.4 Configurations Menu

Use the Configurations menu to save test configurations and switch between saved configurations.

1. Touch the **Configuration** button to display the Configurations menu (Figure 8-5).

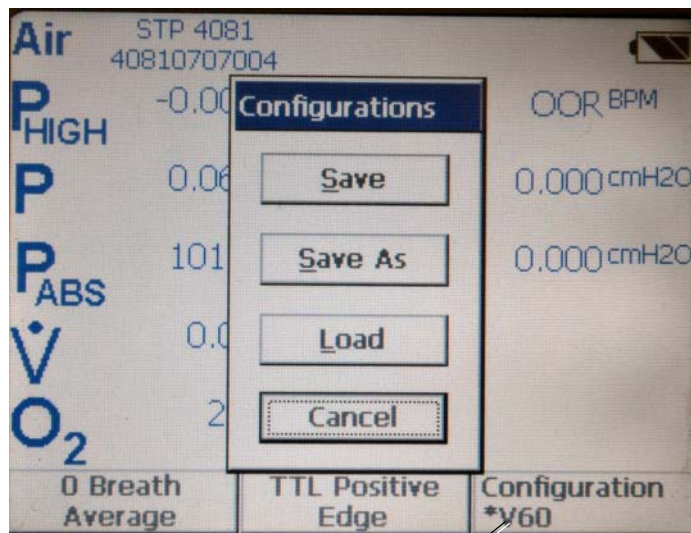

Configuration button

Figure 8-5: Configurations Menu (Certifier FA Plus)

- To create a Respironics folder, touch **Save As**, then touch **New Folder** (Figure 8-6). If a Respironics folder already exists go to step 4.

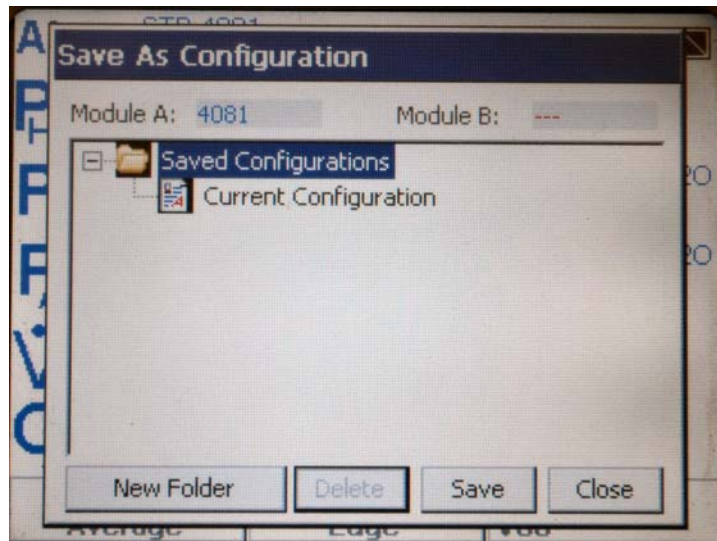

Figure 8-6: Save As Configuration - New Folder Button (Certifier FA Plus)

- Use the touch screen keyboard to enter **RESPIRONICS**, then touch **OK** (Figure 8-7).

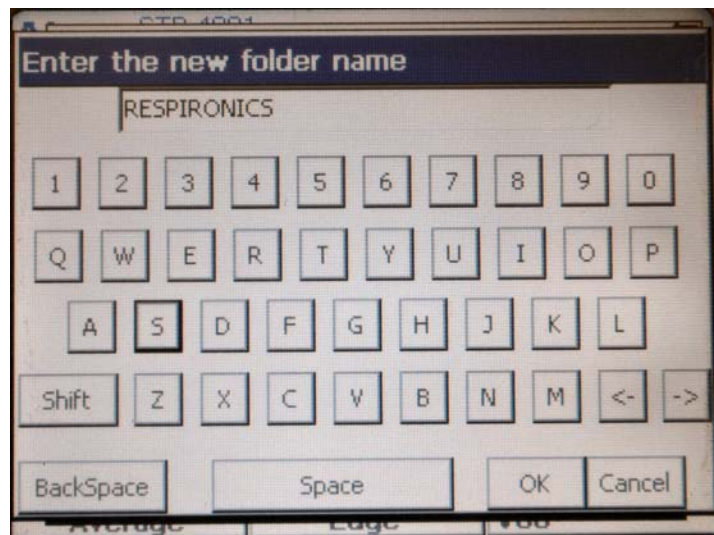

Figure 8-7: Entering a New Folder Name (Certifier FA Plus)

4. Highlight *RESPIRONICS* and touch **Save** (Figure 8-8).

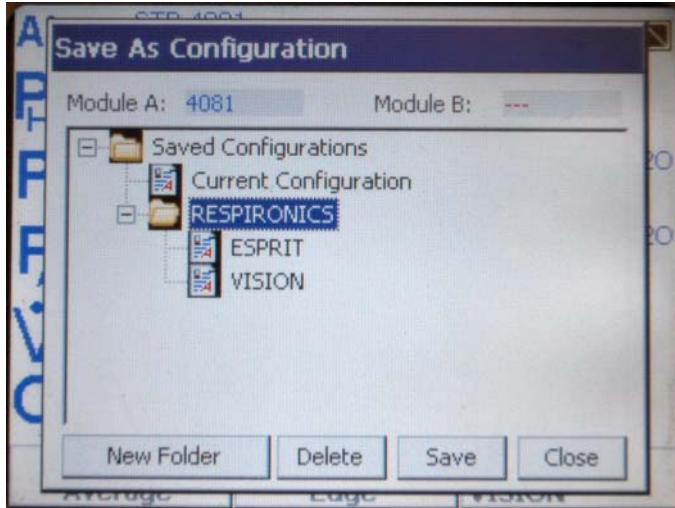

Figure 8-8: Saving a New Configuration to the RESPIRONICS Folder (Certifier FA Plus)

5. Use the touch screen keyboard to enter the new configuration name (**V60**), then touch **OK** (Figure 8-9).

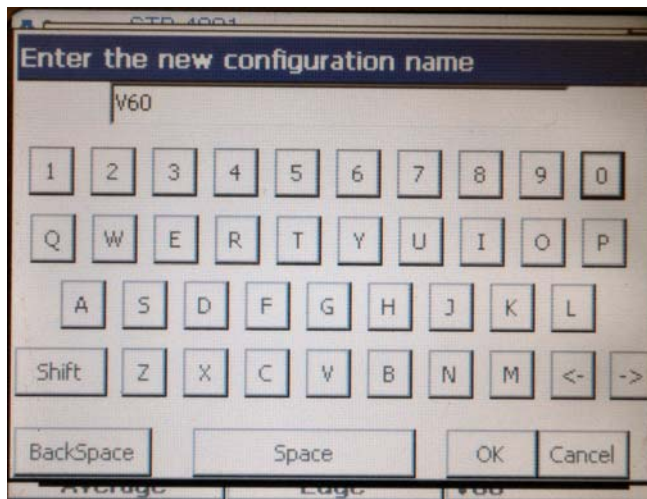

Figure 8-9: Entering a New Configuration Name (Certifier FA Plus)

8.5 Performance Verification Procedures

When running a complete performance verification, perform the tests in order to ensure logical fault diagnosis. If the ventilator fails any performance verification test, see section 8.7, *Performance Verification Troubleshooting/Repair* for troubleshooting instructions. Fill in the applicable parts of the Performance Verification Data Form as each test is completed.

8.5.1 Electrical Safety (Test 1)

The electrical safety test verifies that the ground resistance and forward and reverse leakage current are within specified limits (Figure 8-10).

Required equipment:

- 0.25-in. test adapter
 - Needle nose vise grips
 - Electrical safety analyzer
1. Check that the ground resistance $< 0.2 \text{ ohm } (\Omega)$ at these test points:
 - Gas outlet port
 - Proximal pressure port
 - Oxygen fitting retention plate
 2. Attach the 0.25-in. test adapter to the gas outlet port.
 3. Turn the ventilator on and check that the cooling fan is operating correctly.
 4. Check that the forward and reverse leakage current is:
 - $< 300 \text{ microamperes } (\mu\text{A})$ for ventilators connected to 100-120 VAC/60 Hz.
 - $< 500 \mu\text{A}$ for ventilators connected to 220-240 VAC/50 Hz.
 5. The electrical safety test is complete.

Chapter 8
Performance Verification

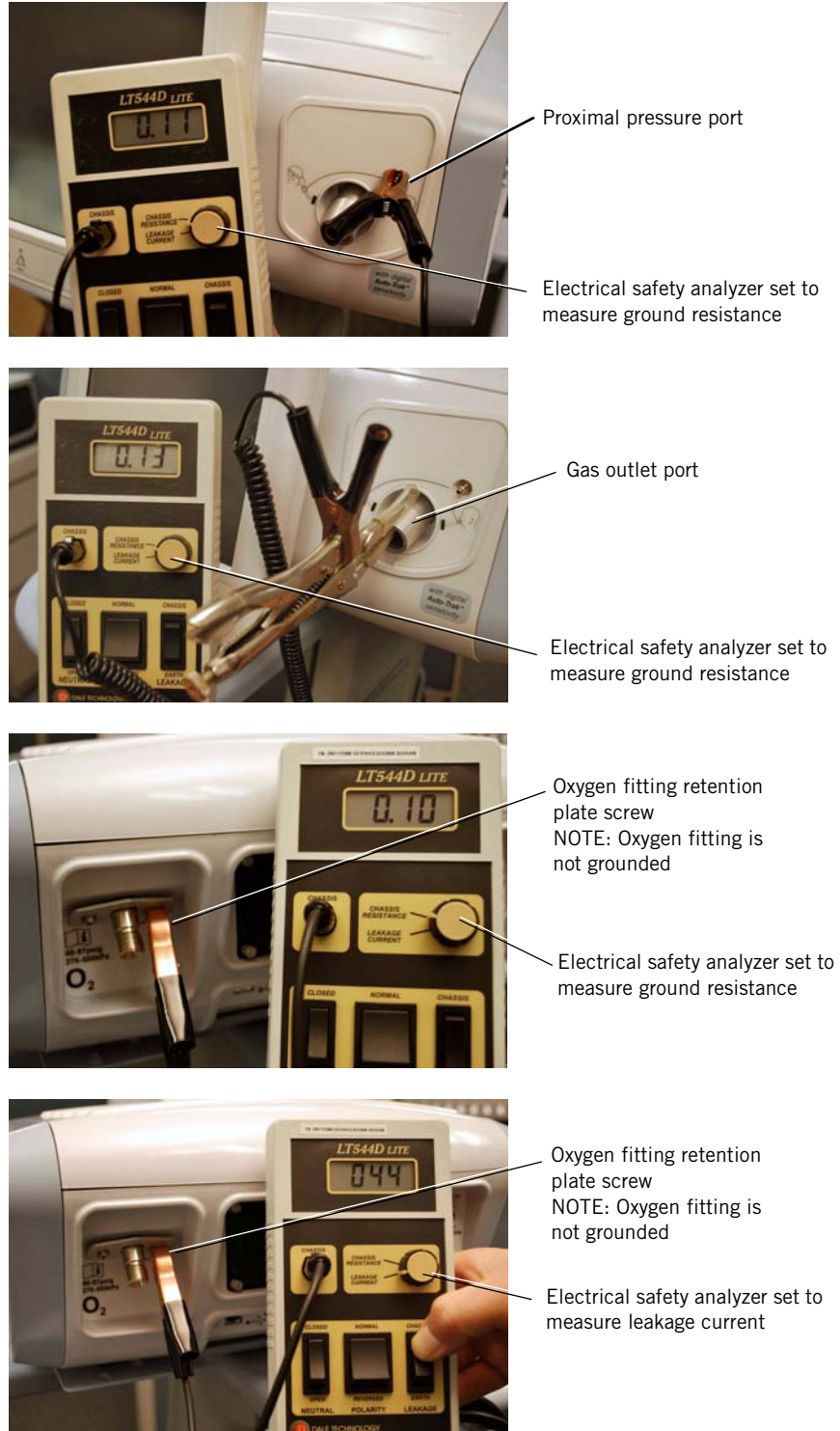

Figure 8-10: Electrical Safety Testing

8.5.2 Leak Tests (Test 2)

Leak tests include:

- *High pressure leak test:* verifies that there are no leaks on the high-pressure (oxygen) side of the GDS.
- *System leak test:* verifies that there are no leaks on the low pressure side of the GDS, or connections between the rubber boots, blower patient outlet, and internal tubing.

Figure 8-11 shows the test configuration for the leak tests.

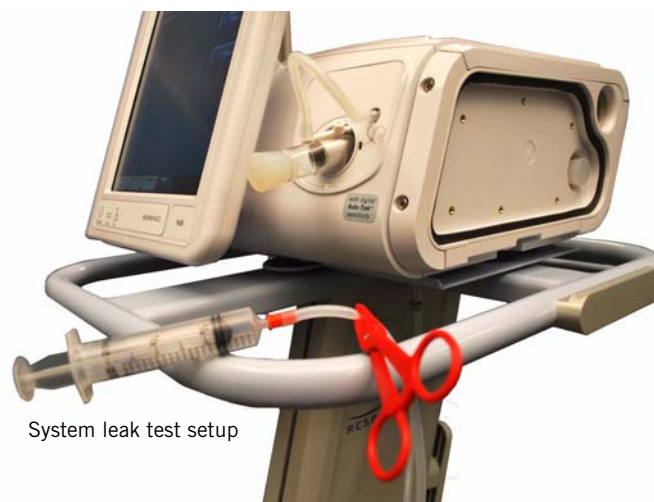

Figure 8-11: Leak Tests Configuration

High Pressure Leak Test

Required equipment:

- Certifier FA Plus analyzer
 - Oxygen shut-off valve
1. If the ventilator is not already in Diagnostic mode, press and hold the **Enter** button on the nav-ring and turn the ventilator on by pressing the **On/Shutdown** button. Within 5 seconds release and press the nav-ring **Enter** button again to enter the Diagnostics menu.
 2. Connect the oxygen regulator/shut-off valve to the ventilator and to the Certifier FA Plus, and connect oxygen. (Touch **Service**, then **Pneumatics**, and verify that the O₂ inlet display and the analyzer display read 45 to 50 psig.)
 3. Touch **Misc**, then touch **High Pressure Leak Test** and follow the onscreen prompts (Figure 8-12).
 4. Touch **Close** and then remove the oxygen regulator/shut-off valve.
 5. The high pressure leak test is complete.

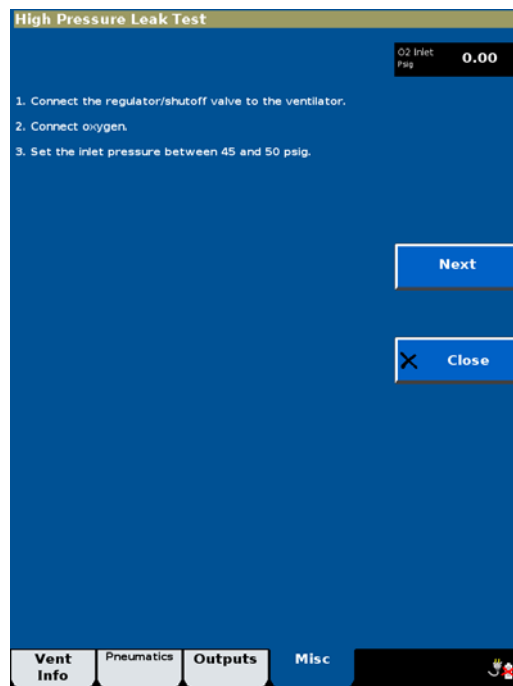

Figure 8-12: High Pressure Leak Test Screen

System Leak Test

Required equipment:

- $\frac{9}{16}$ - $\frac{3}{4}$ in. tapered plug (2)
- Clamp (hemostat)
- Pressure pick-off port
- System leak test syringe

1. Remove the right side cover, air inlet filter retainer, and air inlet housing to access the GDS (section 7.20).
2. Plug the air inlet, gas outlet, and patient pressure ports. Verify that the system leak test syringe is pulled back, then connect it to the internal exhalation port.
3. If the ventilator is not already in Diagnostic mode, press and hold the **Enter** button on the nav-ring and turn the ventilator on by pressing the **On/Shutdown** button on the UI. Within 5 seconds release and press the nav-ring **Enter** button again to enter the Diagnostics menu.
4. Touch **Service, Misc**, then touch **System Leak Test** and follow the onscreen prompts (Figure 8-13).
5. Touch **Close**, then remove the plugs and system leak test syringe.
6. Reinstall the inlet filter housing, inlet filter retainer, and the right side cover (Chapter 7).
7. The system leak test is complete.

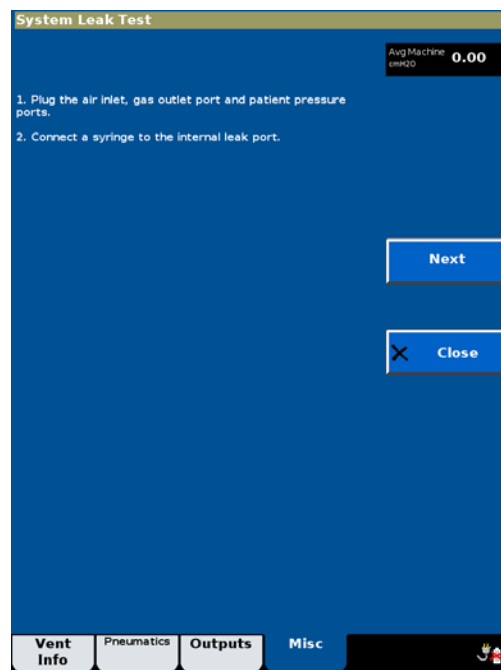

Figure 8-13: System Leak Test Screen

8.5.3 Controls (Test 3)

The controls test verifies that the touch screen, nav-ring, and nav-ring Enter button work correctly.

Required equipment:

- 0.25-in. test adapter.
1. If the ventilator is not already in normal ventilation mode, cycle power to the ventilator to enter normal ventilation, attach a 0.25-in. test adapter, and verify that the AC power icon is displayed on the UI.
 2. Verify that the ON/Shutdown LED is green.
 3. Select these ventilator settings and alarm limits:

Ventilator settings	Alarm limits
Mode: S/T	High Rate: 30 BPM
IPAP: 20 cmH ₂ O	Low Rate: 4 BPM
EPAP: 4 cmH ₂ O	Hi Vt: 2500 mL
Rate: 12 BPM	Lo Vt: OFF mL
I-Time: 1.00 sec	HIP: 50 cmH ₂ O
Rise: 1	LIP: OFF cmH ₂ O
Ramp: OFF	Low VE: OFF L/min
O ₂ : 21%	LIP T: 20 sec

4. Touch **IPAP** to display the IPAP adjustment screen, then use the nav-ring to change the value to 40.
5. Press the nav-ring Enter button to accept the new setting.
6. Touch **IPAP** to display the IPAP adjustment screen, then use the touch screen arrows to return the IPAP setting to 20.
7. Touch **Menu**, then **Brightness** and verify that the display information is visible when brightness is set to its minimum value.
8. Adjust brightness to 5, then touch **Close**.
9. Touch **Screen Lock**, then attempt to change a setting. Verify that the user interface displays *Screen Locked* at the top of the screen.
10. Press the nav-ring Enter button to unlock the screen.
11. Press the **On/Shutdown** button, then touch **Ventilator Shutdown**.
12. Verify that the ON/Shutdown LED is amber.
13. The controls test is complete.

8.5.4 Pressure Accuracy (Test 4)

The pressure accuracy test verifies the accuracy of the inhalation and exhalation pressure transducers.

Required equipment:

- Low-pressure plug
- $\frac{9}{16}$ - $\frac{3}{4}$ in. tapered plug
- 22-mm connector
- Pressure pick-off port
- 18-in. smooth-bore tubing
- Proximal pressure line assembly
- Certifier FA Plus analyzer

1. If the ventilator is not already in diagnostic mode, press and hold the nav-ring Enter button and turn the ventilator on by pressing the **On/Shutdown** button on the user interface. Within 5 seconds release and press the nav-ring **Enter** button again to enter the Diagnostics Menu.
2. Touch **Service**, then **Pneumatics**.
3. Plug the internal exhalation port orifice (Figure 8-14).

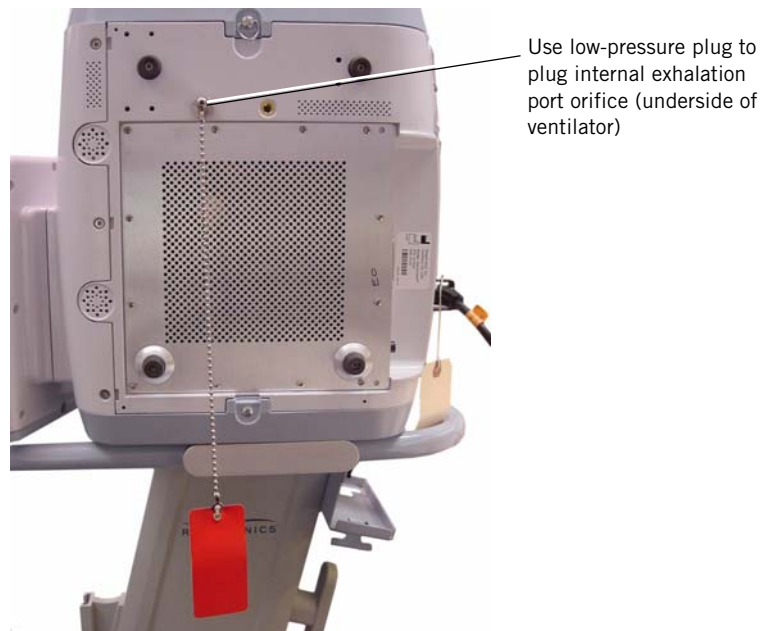

Figure 8-14: Plug Internal Exhalation Port Orifice

4. Verify that the barometric pressure reading displayed on the ventilator is within $\pm 3.5\%$ of the analyzer reading.

Performance Verification

5. Set the analyzer's pressure range to measure at least 60 cmH₂O, and connect the pneumatic calibration analyzer to the ventilator as shown (Figure 8-15).

NOTE: Zero the analyzer transducers, if required.



Figure 8-15: Pressure Accuracy Test Configuration

6. Configure the diagnostic screen (Figure 8-16) as follows:
 - Pressure: 0 cmH₂O
 - Flow: 0 SLPM
 - O₂: 21%
 - Solenoid 1: None
 - Solenoid 2: Machine Pressure Line
 - Solenoid 3: Machine Pressure Line
 - Solenoid 4: Prox Pressure



Figure 8-16: Diagnostics Menu - Pneumatics Tab Selected

- Set ventilator pressure values and verify that they correspond to pressure measurements:

NOTE: Add the machine pressure offset reading (pneumatics screen) at 0 to the analyzer readings for 1, 35, and 60 cmH₂O.

Set Pressure to:	Verify that analyzer, average <i>Machine</i> , and <i>Proximal</i> displays read:
0 cmH ₂ O	-1.5 to 1.5 cmH ₂ O
1 cmH ₂ O	0.5 to 1.5 cmH ₂ O
35 cmH ₂ O	32.5 to 38.5 cmH ₂ O
60 cmH ₂ O	54 to 66 cmH ₂ O

- To reset the pressure setting to 0, touch **Flow** then **Accept**.
- The pressure accuracy test is complete. *Remove low-pressure plug if additional testing is not required.*

8.5.5 Air Delivery/Flow Accuracy (Test 5)

The air delivery flow accuracy test verifies the accuracy of the air flow sensor and function of the blower.

Required equipment (air delivery):

- Coupling, straight, silicone
- Ball valve
- 22-mm connector
- Pressure pick-off port
- 18-in. smooth-bore tubing
- Proximal pressure line assembly
- Certifier FA Plus analyzer

1. If the ventilator is not already in diagnostic mode, press and hold the nav-ring Enter button and turn the ventilator on by pressing the **On/Shutdown** button on the user interface. Within 5 seconds release and press the nav-ring **Enter** button again to enter the Diagnostics Menu.
2. Touch **Service**, then **Pneumatics**.
3. Disconnect the oxygen source to the ventilator.
4. Plug the internal exhalation port orifice (Figure 8-14).
5. Connect a ball valve and pneumatic calibration analyzer to the ventilator, set analyzer gas source to *Air* and select *STP* mode (Figure 8-17).



Figure 8-17: Air Delivery Test Configuration

6. Set the analyzer's flow range to measure at least 100 cmH_2O and 230 SLPM.

7. Configure the diagnostic screen as follows:
 - Pressure: *0 cmH₂O*
 - Flow: *0 SLPM*
 - O₂: *21%*
 - Solenoid 1: *None*
 - Solenoid 2: *Machine Pressure Line*
 - Solenoid 3: *Machine Pressure Line*
 - Solenoid 4: *Prox Pressure*
8. Ensure that the ball valve is fully open, then touch **Flow** and set to 200 SLPM.
9. Begin closing the ball valve until the low pressure display on the analyzer is greater than 64.42 cmH₂O. Verify that the flow displayed on the analyzer is greater than 136.8 SLPM.
10. Touch **Pressure**, then **Accept** to zero the flow setting.
11. Disconnect and remove the ball valve and pressure pick-off port from the ventilator.

Required equipment (flow accuracy):

- Low-pressure plug
 - 22-mm connector
 - Pressure pick-off port
 - 18-in. smooth-bore tubing
 - Proximal pressure line assembly
 - Certifier FA Plus analyzer
12. If the ventilator is not already in diagnostic mode, press and hold the nav-ring **Enter** button and turn the ventilator on by pressing the **On/Shutdown** button on the user interface. Within 5 seconds release and press the nav-ring **Enter** button again to enter the Diagnostics menu.
 13. Connect the pneumatic calibration analyzer to the ventilator, set analyzer gas source to *Air*, and select *STP* mode (Figure 8-18).



Figure 8-18: Air Flow Accuracy Test Configuration

Performance Verification

14. Verify that the set air flow values correspond to the flow measurements:

NOTE: When using the Certifier FA Plus the air delivery/flow accuracy test requires that the temperatures of the delivered gas and ambient air must be within 10 °C of each other, and that the relative humidity of the gas must be less than 30% at 21.1 °C. Most air flow analyzer flow sensors are sensitive to relative humidity, and typically indicate higher-than-actual air flow readings when the relative humidity is above 10%. Consult the manufacturer's instructions for correcting any air flow inaccuracies due to high relative humidity.

Set Flow to:	Verify that analyzer and average <i>Air Flow</i> displays read:
10 SLPM	9 to 11 SLPM
120 SLPM	108 to 132 SLPM
230 SLPM	207 to 253 SLPM (N/A if above 6400 feet)

15. Remove the low-pressure plug and verify that the flow reading on the analyzer drops by more than 15 SLPM.
16. Touch **Pressure** then **Accept** to zero the flow setting.
17. The air delivery/flow accuracy test is complete.

8.5.6 Oxygen Flow Accuracy (Test 6)

The oxygen flow accuracy test verifies the accuracy of the oxygen flow sensor and function of the oxygen valve.

Required equipment:

- Low-pressure plug
- 22-mm connector
- Pressure pick-off port
- 18-in. smooth-bore tubing
- Proximal pressure line assembly
- Certifier FA Plus analyzer

1. If the ventilator is not already in diagnostic mode, press and hold the nav-ring Enter button and turn the ventilator on by pressing the **On/Shutdown** button on the user interface. Within 5 seconds release and press the nav-ring Enter button again to enter the Diagnostics menu.
2. Touch **Service**, then **Pneumatics**.
3. Connect the oxygen source to the ventilator.
4. Plug the internal exhalation port orifice (Figure 8-14).
5. Connect the pneumatic calibration analyzer to the ventilator, set analyzer gas source to *O₂* and select *STP* mode (Figure 8-19).



Figure 8-19: Oxygen Flow Accuracy Test Configuration

6. Set the analyzer flow range to measure at least 130 LPM.

Performance Verification

7. Configure the diagnostic screen as follows:
 - Pressure: *0 cmH₂O*
 - Flow: *0 SLPM*
 - O₂: *100%*
 - Solenoid 1: *None*
 - Solenoid 2: *Machine Pressure Line*
 - Solenoid 3: *Machine Pressure Line*
 - Solenoid 4: *Prox Pressure*
8. Verify that the set oxygen flow values correspond to the flow measurements:

Set Flow to:	Verify that analyzer and average <i>O₂ Flow</i> displays read:
10 SLPM	9 to 11 SLPM
140 SLPM	126 to 154 SLPM

9. Touch **Pressure** then **Accept** to zero the flow setting.
10. Touch **O₂** and set to 21%.
11. The oxygen flow accuracy test is complete. Remove low-pressure plug.

8.5.7 Oxygen Accuracy (Test 7)

The oxygen accuracy test verifies the accuracy of the oxygen percentage delivered to the patient.

Required equipment:

- 22-mm connector
- Pressure pick-off port
- 18-in. smooth-bore tubing
- Proximal pressure line assembly
- Whisper Swivel
- Ingmar test lung
- Certifier FA Plus analyzer with oxygen sensor

1. Connect a patient circuit, including test lung, Whisper Swivel, and analyzer to the ventilator (Figure 8-20).
 - Set the analyzer to measure oxygen.
 - Set up the test lung with an Rp20 and a compliance of 20.



Figure 8-20: Oxygen Accuracy Test Configuration

2. If the ventilator is not already in normal ventilation mode, cycle power to the ventilator to enter normal ventilation mode.

Performance Verification

3. Select these ventilator settings and alarm limits:

Ventilator settings	Alarm limits
Mode: S/T	High Rate: 30 BPM
IPAP: 20 cmH ₂ O	Low Rate: 4 BPM
EPAP: 4 cmH ₂ O	Hi Vt: 2500 mL
Rate: 12 BPM	Lo Vt: OFF mL
I-Time: 1.00 sec	HIP: 50 cmH ₂ O
Rise: 1	LIP: OFF cmH ₂ O
Ramp: OFF	Low VE: OFF L/min
O ₂ : 21%	LIP T: 20 sec

4. With the oxygen source disconnected, touch **O2** and set to 22%.
5. Verify that the ventilator alarms and displays *Oxygen Not Available*.
6. Touch **O2** and set to 21%, reset alarms.
7. Connect an oxygen source to the ventilator.

NOTE: Calibrate the oxygen analyzers sensor prior to proceeding.

8. Verify that the set O₂% values corresponds to the measured values:

Touch O2 and set to:	Verify that analyzer measures:
21%	18 to 24% (after 12 breaths)
30%	27 to 33% (after 12 breaths)
60%	57 to 63% (after 12 breaths)
100%	97 to 103% (after 12 breaths)

9. Touch **O2** and set to 21%.
10. The oxygen accuracy test is complete.

8.5.8 S/T Performance (Test 8)

The S/T performance test verifies the accuracy of the IPAP and EPAP settings.

Required equipment:

- 22-mm connector
- Pressure pick-off port
- 18-in. smooth-bore tubing
- Proximal pressure line assembly
- Whisper Swivel
- Ingmar test lung
- TTL communications cable
- Certifier FA Plus analyzer

1. Connect a patient circuit, including test lung, Whisper Swivel, TTL cable, and analyzer to the ventilator (Figure 8-21).



Figure 8-21: S/T Performance Test Configuration

2. Set up the test lung with an Rp20 and a compliance of 20.
3. If the ventilator is not already in normal ventilation mode, cycle power to the ventilator to enter normal ventilation mode.
4. Set the analyzer to display peak inspiratory pressure (PIP) and positive end expiratory pressure (PEEP).

Performance Verification

5. Select these ventilator settings and alarm limits, and reset any alarms if necessary:

Ventilator settings	Alarm limits
Mode: S/T	High Rate: 30 BPM
IPAP: 15 cmH ₂ O	Low Rate: 4 BPM
EPAP: 4 cmH ₂ O	Hi Vt: 2500 mL
Rate: 12 BPM	Lo Vt: OFF mL
I-Time: 1.00 sec	HIP: 50 cmH ₂ O
Rise: 2	LIP: OFF cmH ₂ O
Ramp: OFF	Low VE: OFF L/min
O2: 21%	LIP T: 20 sec

6. Allow the ventilator to operate for at least one minute.
7. Watch the waveforms on the V60 display to verify that the unit cycles between IPAP and EPAP.
8. Verify that the set IPAP and EPAP values correspond to these measurements:

Select this setting:	Verify that analyzer measures:
IPAP = 40 cmH ₂ O	36.4 to 43.6 cmH ₂ O (PIP)
EPAP = 25 cmH ₂ O	22 to 28 cmH ₂ O (PEEP)

9. The S/T performance test is complete.

8.5.9 Alarms (Test 9)

This test verifies the performance of the alarm outputs.

Required equipment:

- 22-mm connector
- Pressure pick-off port
- 18-in. smooth-bore tubing
- Proximal pressure line assembly
- Whisper Swivel
- Ingmar test lung
- Certifier FA Plus analyzer
- DMM
- Remote alarm test cable
- Remote alarm test cable adapter

1. Connect a patient circuit, including test lung, Whisper Swivel, and analyzer to the ventilator (Figure 8-22).



Figure 8-22: Alarms Test Configuration

2. Set up the test lung with an Rp20 and a compliance of 20.
3. If the ventilator is not already in normal ventilation mode, cycle power to the ventilator to enter normal ventilation mode.

Performance Verification

4. Select these ventilator settings and alarm limits:

Ventilator settings	Alarm limits
Mode: S/T	High Rate: 30 BPM
IPAP: 10 cmH ₂ O	Low Rate: 4 BPM
EPAP: 4 cmH ₂ O	Hi Vt: 2500 mL
Rate: 12 BPM	Lo Vt: OFF mL
I-Time: 1.00 sec	HIP: 50 cmH ₂ O
Rise: 1	LIP: OFF cmH ₂ O
Ramp: OFF	Low VE: OFF L/min
O ₂ : 21%	LIP T: 20 sec

5. Connect the adapter's double banana plugs to the DMM with the GND tab to the common jack and set the DMM to measure resistance.
6. Connect the grey RCA plug (labeled *TIP*) of the remote alarm test cable to the adapter.
7. Plug the ¼ - in. phono connector into the remote alarm phono jack at the back of the ventilator.
8. Reset any alarms if necessary and verify that the DMM reads infinite resistance (open circuit).
9. Remove the grey RCA plug from the adapter and connect the orange RCA plug (labeled *RING*) in its place.
10. Reset any alarms if necessary, and verify that the DMM reads 0.0 ± 3 ohms.
11. Disconnect the proximal line from the ventilator to create a *Proximal Pressure Line Disconnect* alarm.
12. Touch **Menu**, then **Loudness**, and verify that the audible alarm is still audible when set to 1 and steadily becomes louder as the value increases to 10.
13. Verify that the DMM reads infinite resistance (open circuit).
14. Remove the orange RCA plug from the adapter and connect the grey RCA plug (labeled *TIP*) in its place.
15. Verify that the DMM reads 0.0 ± 3 ohms.
16. Reconnect the proximal line to the ventilator and verify that the audible alarm is automatically silenced.
17. Remove the adapter from the DMM and the remote alarm test cable from the remote alarm phono jack.
18. The alarms test is complete.

8.5.10 Power Fail (Test 10)

This test verifies the integrity of the power fail alarm.

Required equipment:

- 0.25-in. test adapter.

If the internal battery *is* installed:

1. Turn ventilator power off and disconnect power cord from AC outlet.
2. Disconnect the internal battery from the ventilator.
3. Reconnect the power cord to the AC outlet.
4. Connect a 0.25-in. test adapter to the gas outlet port.
5. Turn the ventilator on in normal ventilation mode.
6. With the ventilator operating on AC power, unplug the power cord from the AC outlet.
7. Verify that the audible alarm sounds and start a stopwatch. After 2 minutes, verify that the audible alarm is still sounding.
8. Press and hold the **On/Shutdown** button for about 5 seconds to turn ventilator power off, then verify that the audible alarm is silenced.
9. Reconnect the internal battery to the ventilator.
10. Plug the ventilator into an AC outlet and verify that the battery icon changes to the AC icon.
11. The power fail alarm test is complete.

If the internal battery is *not* installed:

1. Connect a test adapter to the gas outlet port.
2. Turn the ventilator on in normal ventilation mode, then unplug the power cord from the AC outlet.
3. Verify that the audible alarm sounds and start a stopwatch. After 2 minutes, verify that the audible alarm is still sounding.
4. Press and hold the **On/Shutdown** button for about 5 seconds to turn ventilator power off, then verify that the audible alarm is silenced.
5. The power fail alarm test is complete.

8.5.11 Internal Battery (Test 11)

This test verifies that the ventilator can transition to and from optional battery power. Do not perform this test if the internal battery is not installed.

Required equipment:

- 0.25-in. test adapter.

NOTE: The internal battery (if installed) should be fully charged before performing this test. If the internal battery is not fully charged, this test may fail. Record the result of this test as *Limited use* on the Performance Verification Data Form until the internal battery is charged and internal battery test passes.

1. If the ventilator is not already in Diagnostic mode, press and hold the nav-ring **Enter** button and turn on the ventilator by pressing the **On/Shutdown** button on the user interface. Within 5 seconds, release and press the nav-ring **Enter** button again to enter the Diagnostic menu.
2. Connect a 0.25-in. test adapter to the gas outlet port.
3. Touch **Service, Pneumatics**, and then **Pressure** and set the pressure to 65 cmH₂O.
4. Unplug the AC power cord and verify that ventilator operation continues uninterrupted and that *Battery %* on the diagnostic screen is above 70%.
5. Allow ventilator to a minimum of 20 minutes on battery power, then verify that the *Battery %* displayed on the diagnostic screen is at least 70%.
6. With AC still disconnected, cycle power to the ventilator and allow it to come up in normal ventilation.
7. Verify that the ventilator operates in normal ventilation, the message *Running on Internal Battery* is displayed in the Alert window, the *Battery In Use* icon is displayed, and the *Battery Low* alarm is off.
8. Reconnect the AC power cord. Verify that ventilator operation is uninterrupted, the *AC* icon is displayed, and the *Battery* icon turns off.
9. Verify that the *Battery Charging* LED begins flashing within 30 seconds.
10. The internal battery test is complete.

8.6 Returning Ventilator to Operation

Follow these steps to return the ventilator to operation after a successful performance verification:

1. Remove all test equipment, tools, and materials from ventilator.
2. Verify that the internal exhalation port orifice is *not* plugged.
3. If the ventilator is not already in diagnostic mode: power up the ventilator: press and hold the nav-ring **Enter** button and the **On/Shutdown** button on the user interface. Within 5 seconds of power up, release and press the nav-ring **Enter** button to enter the Diagnostics menu.
4. Touch **System Settings**, and then **Restore Default Settings**.
5. Touch **Date/Time** and verify that the date and time are correct.
6. Turn ventilator OFF.

8.7 Performance Verification Troubleshooting/Repair

Use the following troubleshooting procedures if the ventilator fails a performance verification test. Make sure that the external measurement devices such as the pneumatic calibration analyzer are calibrated and functioning properly.

Perform the repair procedures in the order listed until the problem is resolved. (See Chapter 5 for diagnostic mode procedures, and Chapter 7 for component replacement procedures.)

CAUTION: Troubleshooting and repair should be performed only by a qualified service technician.

8.7.1 Test 1: Electrical Safety

Symptom	Recommended Repair
Ground resistance out of range	<ol style="list-style-type: none"> 1. Verify that the AC outlet is properly grounded. Try another AC outlet. 2. Verify that the AC power cord is completely inserted into the AC inlet. 3. Check for secure connections of AC mains ground wires, power supply, gas outlet, proximal pressure port, and GDS. 4. Check for visible damage to the power cord. 5. Replace power cord.
Cooling fan not operating	<ol style="list-style-type: none"> 1. Check that the fan wires are properly seated in the connector on the MC PCBA. 2. Slave in a replacement fan and replace if it is operational. 3. Replace the MC PCBA.
Forward/reverse leakage current out of range	<ol style="list-style-type: none"> 1. Check for secure connections of ground wires from the AC inlet, power supply, and GDS. 2. Replace power cord and rerun test. 3. Check for pinched cables and harnesses or damaged wire insulation throughout the ventilator. 4. Replace power supply and rerun test.

8.7.2 Test 2: Leak Tests

Symptom	Recommended Repair
Oxygen inlet reading out of range (45-50 psig)	<ol style="list-style-type: none"> 1. Verify that oxygen source is adequate for this test. 2. Check for leaks at the oxygen fitting. 3. Check that the oxygen solenoid valve is fully closed by verifying that there is zero flow across the oxygen flow sensor. If not, replace the oxygen solenoid valve. 4. Verify that the oxygen pressure transducer is reading correctly. If not, replace the DA PCBA.

Symptom	Recommended Repair
High pressure leak test fails	<ol style="list-style-type: none"> 1. Verify that oxygen source is adequate for this test. 2. Check for leaks at the oxygen fitting, oxygen filter element cap, oxygen solenoid valve, and oxygen pressure transducer. 3. Check that the oxygen solenoid valve is fully closed by verifying that there is zero flow across the oxygen flow sensor. If not, replace the oxygen solenoid valve. 4. Verify that the oxygen pressure transducer is reading correctly. If not, replace the DA PCBA.
System pressure leak test fails	<ol style="list-style-type: none"> 1. Verify that the internal exhalation port, air inlet port, gas outlet port, and proximal port are plugged properly. 2. Verify that system leak test syringe tubing is properly clamped. 3. Check for disconnected or cut tubing from the GDS to the gas outlet port, and from the gas outlet port to the base. 4. Check for misaligned or cut rubber boots from the GDS to the blower, and from the blower to the gas outlet port. 5. Check for leaks at the flow sensor assembly, solenoid valves, and pressure transducers. 6. Verify that the machine and proximal pressure transducers are reading correctly. If not, replace the DA PCBA.

8.7.3 Test 3: Controls

Symptom	Recommended Repair
Touch screen not responding properly	<ol style="list-style-type: none"> 1. Calibrate the touch screen. 2. Slave in a different user interface-to-PM PCBA cable, and replace original cable if the problem is resolved. 3. Replace PM PCBA. 4. Replace the CPU PCBA.
Nav-ring not responding properly	<ol style="list-style-type: none"> 1. Verify connections between the nav-ring and the switch PCBA. 2. Slave in a different switch PCBA cable, and replace the original cable if the problem is resolved. 3. Replace the nav-ring assembly.
On/Shutdown switch not responding properly	<ol style="list-style-type: none"> 1. Verify connections between power switch overlay and UI PCBA. 2. Slave in a different power switch overlay and replace original overlay if this resolves the problem.

Performance Verification

8.7.4 Test 4: Pressure Accuracy

Symptom	Recommended Repair
Average machine or proximal pressure readings out of range	<ol style="list-style-type: none"> 1. Verify that the internal exhalation port orifice is plugged. 2. Check for leaks at circuit connections, calibration analyzer, filters, etc. 3. Check for kinked or cut tubing from GDS to gas outlet port, and from the gas outlet port to the base. 4. Check for kinked or cut rubber boots from the GDS to the blower, and from the blower to the gas outlet port. 5. Check for leaks at the solenoid valves and pressure transducers. 6. Replace the DA PCBA.

8.7.5 Test 5: Air Delivery/Flow Accuracy

Symptom	Recommended Repair
Measured air flow values out of range	<ol style="list-style-type: none"> 1. Verify that the internal exhalation port orifice is plugged. 2. Verify that the calibration analyzer is set to measure air in STP mode. 3. Check that nothing is obstructing the ventilator gas outlet port. 4. If air flow sensor reading is not within limits as compared to the calibration analyzer, replace the flow sensor assembly. 5. Slave in a different air flow sensor to data acquisition cable. 6. Replace the DA PCBA.

8.7.6 Test 6: Oxygen Flow Accuracy

Symptom	Recommended Repair
Measured oxygen flow values out of range	<ol style="list-style-type: none"> 1. Verify that the internal exhalation port orifice is plugged. 2. Verify that the calibration analyzer is set to measure oxygen in STP mode. 3. Check that nothing is obstructing the ventilator gas outlet port. 4. If oxygen flow sensor reading is not within limits as compared to the calibration analyzer, replace the flow sensor assembly. 5. Slave in a different oxygen flow sensor to DA PCBA cable. 6. Replace the DA PCBA.

8.7.7 Test 7: Oxygen Accuracy

Symptom	Recommended Repair
The measured oxygen percentage is out of range	<ol style="list-style-type: none"> 1. Check that test oxygen monitor is calibrated. 2. Verify that the external oxygen sensor is oriented with cable connector on top. 3. Replace the external oxygen sensor and retest. 4. Replace the oxygen solenoid valve.

8.7.8 Test 8: S/T Performance

Symptom	Recommended Repair
IPAP and EPAP outside acceptable value	<ol style="list-style-type: none"> 1. Verify correct test setup. 2. Check for leaks at circuit connections, test lung, analyzer, etc. 3. Replace DA PCBA. 4. Replace MC PCBA. 5. Replace CPU PCBA.

8.7.9 Test 9: Alarms

Symptom	Recommended Repair
Normally open or normally closed relay test failure (continuity check)	1. Verify continuity of remote alarm test cable. 2. Replace CPU PCBA.
Primary alarm volume not adjustable	Slave in PCBAs in this order until the problem is resolved: MC PCBA, PM PCBA, CPU PCBA.

8.7.10 Test 10: Power Fail

Symptom	Recommended Repair
Backup audible alarm fails to sound	1. Replace MC PCBA. 2. Replace PM PCBA.
Backup audible alarm fails to sound for at least two minutes	1. Replace MC PCBA. 2. Replace CPU PCBA.
Power switch turned off but backup alarm remains on	1. Replace power switch overlay. 2. Replace MC PCBA.

8.7.11 Test 11: Internal Battery

Symptom	Recommended Repair
Ventilator cannot transition from AC to battery power	<ol style="list-style-type: none"> 1. Verify that battery harness connections are secure. 2. Verify that <i>Battery %</i> is above 50. 3. Replace PM PCBA.
Internal battery becomes depleted prematurely	<ol style="list-style-type: none"> 1. Verify that battery is fully charged before test. 2. Replace internal battery. 3. Replace PM PCBA. 4. Replace power supply.
Connecting AC power resets ventilator	Replace PM PCBA.
When AC power is connected after 10 minutes of battery operation, <i>Battery Charging</i> indicator does not light	Replace PM PCBA.
Following ventilator power cycle, diagnostic code or continuous backup alarm condition occurs	<ol style="list-style-type: none"> 1. Verify that battery is fully charged before test (recharge for up to 8 to 12 hours if fully depleted). 2. Replace an internal battery. 3. Replace PM PCBA.

Performance Verification

8.8 Electrical Safety Data Form

Complete this form at every performance verification. **Make copies of this form for data collection.**

Date: _____ Notification number(s): _____

Customer Information

Name: _____
 Address: _____
 City/State: _____
 Account no.: _____

Preliminary ventilator cleaning and inspection	Circle one	
Was the ventilator damaged?	YES	NO
If yes, provide a brief description of damage and repair:		
Cleaned ventilator exterior?	YES	NO
Inspected cooling fan filter?	YES	NO
Inspected inlet filter?	YES	NO

Serial number:	_____	Software version:	_____
Installed options (circle all that apply):	PAV	AVAPS	C-Flex Ramp
	Other: _____		
Total power-on hours:	_____	Hours since last PM:	_____
Battery lot number:	_____	Battery manufacture date:	_____

Test 1: Electrical safety	Circle one		Passed value	Failed value	Value after repair
	YES	NO			
Proper cooling fan operation?					
Proximal pressure port GND resistance (<0.2 ohm)			ohm	ohm	ohm
Gas outlet port GND resistance (<0.2 ohm)			ohm	ohm	ohm
Oxygen fitting GND resistance (<0.2 ohm)			ohm	ohm	ohm
Forward leakage current 100-120 VAC: <300 uA, 220-240 VAC: <500 uA			uA	uA	uA
Reverse leakage current 100-120 VAC: <300 uA, 220-240 VAC: <500 uA			uA	uA	

Technician's signature

Date

8.9 Performance Verification Data Form

Complete this form at every performance verification. **Make copies of this form for data collection.**

Date: _____ Notification number(s): _____

Customer Information

Name: _____

Address: _____

City/State: _____

Account no.: _____

Preliminary ventilator cleaning and inspection		Circle one	
Was the ventilator damaged?		YES	NO
If yes, provide a brief description of damage and repair:			
Cleaned ventilator exterior?		YES	NO
Inspected cooling fan filter?		YES	NO
Inspected inlet filter?		YES	NO

Serial number:	_____	Software version:	_____
Installed options (circle all that apply):	PAV	AVAPS	C-Flex Ramp
	Other: _____		
Total power-on hours:	_____	Hours since last PM:	_____
Battery lot number:	_____	Battery manufacture date:	_____
Environmental readings:	Barometric pressure: _____ mmHg	Relative humidity: _____ %	Temperature: _____ °C

Test 1: Electrical Safety	Circle one		Pass value	Fail value	Value after repair
	YES	NO			
Proper cooling fan operation?					
Proximal pressure port GND resistance (<0.2 ohm)			ohm	ohm	ohm
Gas outlet port GND resistance (<0.2 ohm)			ohm	ohm	ohm
Oxygen fitting GND resistance (<0.2 ohm)			ohm	ohm	ohm
Forward leakage current 100-120 VAC: <300 uA, 220-240 VAC: <500 uA			uA	uA	uA
Reverse leakage current 100-120 VAC: <300 uA, 220-240 VAC: <500 uA			uA	uA	

Performance Verification

Test 2: Leak Tests	Pass value	Fail value	Value after repair
<i>High pressure leak test, oxygen inlet pressure at 45-50 psig</i>			
Analyzer pressure display (45-50 psig)	psig	psig	psig
Oxygen inlet pressure display (45-50 psig)	psig	psig	psig
Threshold	psig	psig	
Pressure drop	psig	psig	psig
<i>System leak test, machine pressure at 55-60 cmH₂O</i>			
Threshold	cmH ₂ O		
Pressure drop	cmH ₂ O	cmH ₂ O	cmH ₂ O

Test 3: Controls	Circle one			Circle one	
AC power indicator	PASS	FAIL	Touch screen	PASS	FAIL
ON/Shutdown LED green	PASS	FAIL	Brightness control	PASS	FAIL
Nav-ring	PASS	FAIL	Screen lock	PASS	FAIL
Enter button	PASS	FAIL	ON/Shutdown LED amber	PASS	FAIL

Test 4: Pressure Accuracy	Pass value	Fail value	Value after repair
<i>Barometric Pressure</i>			
Analyzer barometric pressure display	mmHg		
Barometric pressure display	mmHg	mmHg	mmHg
<i>Pressure at 0 cmH₂O</i>			
Analyzer pressure display (-1.5 to 1.5 cmH ₂ O)	cmH ₂ O	cmH ₂ O	cmH ₂ O
Avg Machine display (-1.5 to 1.5 cmH ₂ O)	cmH ₂ O	cmH ₂ O	cmH ₂ O
Avg Proximal display (-1.5 to 1.5 cmH ₂ O)	cmH ₂ O	cmH ₂ O	cmH ₂ O
<i>Pressure at 1 cmH₂O</i>			
Analyzer pressure display (0.5 - 1.5 cmH ₂ O)	cmH ₂ O	cmH ₂ O	cmH ₂ O
Avg Machine display (0.5 - 1.5 cmH ₂ O)	cmH ₂ O	cmH ₂ O	cmH ₂ O
Avg Proximal display (0.5 - 1.5 cmH ₂ O)	cmH ₂ O	cmH ₂ O	cmH ₂ O
<i>Pressure at 35 cmH₂O</i>			
Analyzer pressure display (32.5 - 38.5 cmH ₂ O)	cmH ₂ O	cmH ₂ O	cmH ₂ O
Avg Machine display (32.5 - 38.5 cmH ₂ O)	cmH ₂ O	cmH ₂ O	cmH ₂ O
Avg Proximal display (32.5 - 38.5 cmH ₂ O)	cmH ₂ O	cmH ₂ O	cmH ₂ O

Test 4: Pressure Accuracy	Pass value	Fail value	Value after repair
<i>Pressure at 60 cmH₂O</i>			
Analyzer pressure display (54 - 66 cmH ₂ O)	cmH ₂ O	cmH ₂ O	cmH ₂ O
<i>Avg Machine</i> display (54 - 66 cmH ₂ O)	cmH ₂ O	cmH ₂ O	cmH ₂ O
<i>Avg Proximal</i> display (54 - 66 cmH ₂ O)	cmH ₂ O	cmH ₂ O	cmH ₂ O

Test 5: Air Delivery/Flow Accuracy	Pass value	Fail value	Value after repair
<i>Air Delivery</i>			
Analyzer pressure display (> 64.42 cmH ₂ O)	cmH ₂ O	cmH ₂ O	cmH ₂ O
Analyzer flow display (> 136.8 SLPM)	SLPM	SLPM	SLPM
<i>Air flow at 10 SLPM</i>			
Analyzer flow display (9 - 11 SLPM)	SLPM	SLPM	SLPM
<i>Average Air</i> display (9 - 11 SLPM)	SLPM	SLPM	SLPM
<i>Air flow at 120 SLPM</i>			
Analyzer flow display (108 - 132 SLPM)	SLPM	SLPM	SLPM
<i>Avg Air</i> display (108 -132 SLPM)	SLPM	SLPM	SLPM
<i>Air flow at 230 SLPM (N/A if above 6400 feet)</i>			
Analyzer flow display (207 - 253 SLPM)	SLPM	SLPM	SLPM
<i>Avg Air</i> display (207 - 253 SLPM)	SLPM	SLPM	SLPM
Analyzer flow display drops more than 15 SLPM	PASS	FAIL	

Test 6: Oxygen Flow Accuracy	Pass value	Fail value	Value after repair
<i>Oxygen flow at 10 SLPM</i>			
Analyzer flow display (9 - 11 SLPM)	SLPM	SLPM	SLPM
<i>Avg O₂</i> display (9 - 11 SLPM)	SLPM	SLPM	SLPM
<i>Oxygen flow at 140 SLPM</i>			
Analyzer flow display (126 - 154 SLPM)	SLPM	SLPM	SLPM
<i>Avg O₂</i> display (126 - 154 SLPM)	SLPM	SLPM	SLPM

Performance Verification

Test 7: Oxygen Accuracy	Pass value	Fail value	Value after repair
Oxygen setting: 22% , oxygen source disconnected: <i>Oxygen Not Available</i> alarm occurs? (circle one)	PASS	FAIL	
Oxygen setting: 21% (after 12 breaths) External oxygen monitor (18 - 24%)	%	%	%
Oxygen setting: 30% (after 12 breaths) External oxygen monitor (27 - 33%)	%	%	%
Oxygen setting: 60% (after 12 breaths) External oxygen monitor (57 - 63%)	%	%	%
Oxygen setting: 100% (after 12 breaths) External oxygen monitor (97 - 103%)	%	%	%

Test 8: S/T Performance	Pass value	Fail value	Value after repair
<i>Waveform</i>			
Pressure cycles between IPAP and EPAP pressure	PASS	FAIL	
<i>IPAP at 40 cmH₂O</i>			
Analyzer pressure reading = 36.4-43.6 cmH ₂ O	cmH ₂ O	cmH ₂ O	cmH ₂ O
<i>EPAP at 25 cmH₂O</i>			
Analyzer pressure reading = 22-28 cmH ₂ O	cmH ₂ O	cmH ₂ O	cmH ₂ O

Test 9: Alarms	Circle one	
DMM to remote alarm test cable reads infinite resistance with no alarm	PASS	FAIL
DMM reads 0.0 ± 3 ohm with no alarm	PASS	FAIL
Alarm volume steadily increases	PASS	FAIL
DMM reads infinite resistance with alarm	PASS	FAIL
DMM to analog output port reads 0.0 ± 3 ohm with alarm:	PASS	FAIL
Audio alarm is automatically silenced	PASS	FAIL

Test 10: Power Fail	Circle one	
Audible alarm sounds	PASS	FAIL
Audible alarm continues to sound after two minutes	PASS	FAIL
Audible alarm silenced	PASS	FAIL
Battery icon changes to AC icon	PASS	FAIL

Performance Verification

Test 11: Internal Battery	Circle one		
Transition from AC to battery operation does not interrupt ventilator operation and indicators operate correctly	PASS	FAIL	N/A
Ventilator powers up in normal ventilation and indicators operate correctly	PASS	FAIL	N/A
Transition from battery to AC operation does not interrupt ventilator operation and indicators operate correctly	PASS	FAIL	N/A
Battery indicator stops flashing	PASS	FAIL	N/A
Internal battery fully charged	PASS	FAIL	N/A
(Internal Battery is not fully charged if Battery Low message is displayed during normal operation on AC power: performance verification result is <i>LIMITED USE</i>)			

Did the performance verification pass? (circle one)

YES

NO

LIMITED USE*

* *LIMITED USE* indicates that the internal battery operational check failed: recommend that the operator connect the ventilator to AC power for at least 5 hours, then verify battery performance.

Technician's signature

Date

(This page is intentionally blank.)

Chapter 9. Replacement Parts List

This section lists and illustrates components of the V60 ventilator.

NOTE: All repair kits include necessary hardware.

CAUTION: Use only Respironics V60 ventilator repair parts. Only Respironics parts are designed for use in the V60 ventilator. Using non-Respironics parts can alter ventilator reliability or result in damage, and affects the product warranty. Contact Respironics Customer Service at 1-800-345-6443 or 1-724-387-4000.

9.1 Complete Parts List

Table 9-1 lists V60 ventilator replacement parts.

Table 9-1: V60 Ventilator Replacement Parts (Sheet 1 of 6)

Description	Part number
Base assembly, English	1053891
Base assembly, non-English	1053892
Battery, internal	1056921
Battery, lithium	1056169
Bezel, front, English	1053894
Bezel, front, non-English	1053895
Bezel, rear	1053896
Blower assembly	1055434
Boot kit, rubber (GDS-blower and blower-output port boots)	1054197
Box, battery return, V60 ventilator	1056430
Box, shipping, V60 ventilator	1056561
Bracket kit, MC PCBA	1054198
Bracket, battery (left side wall)	1054199
Bracket, capacitor (MC PCBA)	1054200
Bracket, CPU (attached to CPU PCBA, includes connectors)	1054201
Bracket, gas outlet	1054202
Button, nav-ring, package of 5 (front bezel)	1054204
Cable, backlight inverter PCBA	1054206
Cable, DA PCBA-flow sensors	1054218
Cable, DA PCBA-MC PCBA	1054217
Cable, gas outlet to ground	1054219
Cable, GDS GND	1054220

Replacement Parts List

Table 9-1: V60 Ventilator Replacement Parts (Sheet 2 of 6)

Description	Part number
Cable, LCD	1054222
Cable, power harness	1054221
Cable, proximal port to ground	1054106
Cable, switch PCBA	1054223
Cable, UI GND	1054224
Cable, UI-PM PCBA	1054225
Cap, oxygen filter element	1054226
Clamp kit, hose (used to secure boots between GDS, blower, and outlet port)	1054239
Clamp, cable, 3/16-in. dia. (LCD tray)	1054238
Clip, capacitor bracket, ferrite	1054240
Clip, oxygen solenoid valve retainer	1054241
Collar, air inlet	1054242
Cover, CPU	1054243
Cover, top	1054244
End cap, bezel (UI)	1054245
Fan guard, filter, and retainer	1054246
Fan, cooling	1054277
Filter, air inlet, package of 5	1054279
Filter, cooling fan, package of 5	1054280
Filter, oxygen inlet	1054278
Fitting kit, oxygen, CAN/CSA, Canada	1054284
Fitting kit, oxygen, DISS-CGA, USA	1054286
Fitting kit, oxygen, NIST A-8, United Kingdom and Hong Kong	1054297
Fitting kit, oxygen, SIS-AS2896, Australia	1054298
Fitting, barbed, 10-32 to 1/8-in., brass, package of 3 (machine pressure port, patient pressure port)	1054283
Fitting, barbed, white nylon, package of 2 (gas outlet port)	1054282
Flow sensor assembly, air and oxygen	1058898
Foam kit, sound insulation (top cover, base)	1054305
Foot kit, bottom, package of 4	1054302
Front panel assembly (base)	1054306
Gas delivery subsystem (GDS)	1054307
Gasket kit, capacitor bracket kit	1054309
Gasket kit, cord, UI front bezel	1054310
Gasket kit, UI rear bezel	1054312

Replacement Parts List

Table 9-1: V60 Ventilator Replacement Parts (Sheet 3 of 6)

Description	Part number
Gasket, air inlet collar, package of 5	1054308
Gasket, housing, filter inlet (right side wall)	1054311
Gasket, left side panel	1054313
Gasket, right side panel	1054314
Grommet, blower mount, package of 4	1054315
Grommet, transducer, package of 2 (DA PCBA-GDS)	1054316
Housing, air inlet filter	1054317
Inlet, AC	1054318
Label kit, CSA/patent	1054929
Label kit, logo/product (front bezel)	1054321
Label kit, oxygen/class/rating, English	1054322
Label kit, oxygen/class/rating, non-English	1054323
Label, Auto-Trak (front panel)	1054320
Label, AVAPS option (UI)	1054324
Label, battery option (UI)	1054325
Label, C-Flex option (UI)	1054326
Label, patient interface (front panel)	1054352
Label, protective earth ground (base)	1054337
LCD assembly	1054338
Mount, isolation, fan, package of 4	1055324
Mount, oxygen solenoid valve	1054339
Nav-ring assembly (front bezel)	1054340
Nut, hex, kep, M4, package of 10 (base grounding lug)	1054341
Nut, hex, M12x1, stainless steel, package of 10 (nurse call jack)	1055321
Nut, wing, M3, package of 10 (MC PCBA to PCBA bracket)	1056418
O-ring, 2-023, Viton 70 DU, package of 5 (oxygen solenoid valve)	1054347
O-ring, 2-103, Viton 70 DU, package of 5 (DA PCBA-manifold)	1054348
O-ring, 2-121, Viton 50 DU, package of 5 (flow sensor assembly, oxygen filter)	1056662
O-ring, 2-121, Viton 70 DU, package of 5 (flow sensor assembly, oxygen filter)	1054342

Replacement Parts List

Table 9-1: V60 Ventilator Replacement Parts (Sheet 4 of 6)

Description	Part number
O-ring, 2-123, Viton 70 DU, package of 5 (air inlet)	1054343
O-ring, 2-135, Viton 70 DU, package of 5 (flow sensor assembly)	1054344
Overlay, power switch, English (UI)	1054350
Overlay, power switch, non-English (UI)	1054351
Padding, left side wall, package of 2 (battery bracket)	1054353
PCBA, backlight inverter	1054354
PCBA, CPU	1054355
PCBA, data acquisition (DA)	1054356
PCBA, motor controller (MC)	1054357
PCBA, power management (PM)	1054358
PCBA, switch (UI)	1054360
PCBA, user interface (UI)	1054361
Pin, locking, left side panel	1054362
Pin, locking, right side panel	1054363
Pin, push, fan mount, package of 4	1054235
Plate, oxygen fitting retention	1054365
Plate, power supply mounting	1054364
Plate, solenoid retention (used to retain solenoid valves to manifold)	1054366
Plug kit, front panel	1054377
PM kit, annual	1054378
Port, gas outlet (front panel)	1054104
Port, proximal, 1/8-in. (front panel)	1054275
Power cord, Argentina	1049627
Power cord, Australia	1049653
Power cord, China	1049628
Power cord, continental Europe	1043253
Power cord, Denmark	1049018
Power cord, Israel	1050940
Power cord, Italy	1049017
Power cord, North America	1043249
Power cord, South Africa	1043289
Power cord, Switzerland	1049016
Power cord, United Kingdom	1043287
Power supply	1054359

Replacement Parts List

Table 9-1: V60 Ventilator Replacement Parts (Sheet 5 of 6)

Description	Part number
Retainer, air inlet filter	1054105
Retainer, power cord (base)	1054294
Retainer, UI (front panel)	1054208
Ring, dampening, vibration (blower to outlet port boot)	1056191
Screw, 2-32 x 3/8-in. L, self-tap, package of 10 (ferrite clip, capacitor bracket)	1054209
Screw, 6-32 x 1/4-in. L, pan head, package of 10 (power supply/EMI shroud)	1054210
Screw, M1.6 x 4, pan head, package of 10 (LCD to LCD tray)	1054212
Screw, M2.5 x 6, socket head, package of 10 (oxygen solenoid valve clip)	1054214
Screw, M2.5 x 8, pan head, package of 10 (backlight inverter PCBA, AC inlet)	1054215
Screw, M3 x 12, pan head, package of 10 (MC PCBA)	1054229
Screw, M3 x 14, pan head, package of 10 (rear to front bezel, bezel end cap, flow sensor assembly)	1054230
Screw, M3 x 4, pan head, package of 10 (gas outlet port GND wire)	1054216
Screw, M3 x 6, pan head, package of 10 (CPU, CPU cover, speakers, base-CPU tray, power supply to mounting plate and base, PM PCBA, GDS GND wire, UI cable clamp, LCD tray GND wire, LCD-front bezel, switch PCBA, UI PCBA, UI GND wire)	1054227
Screw, M3 x 8, pan head, package of 10 (solenoid valve retention plate, oxygen solenoid valve mount, DA PCBA)	1054228
Screw, M4 x 14, socket head, package of 10 (bottom feet)	1054234
Screw, M4 x 5 dia. x 5 L, shoulder, package of 10 (blower mount)	1054211
Screw, M4 x 8, socket head, package of 10 (power cord retainer, capacitor bracket, battery bracket, top cover to base, base to front panel, base to side walls, air inlet filter frame, gas outlet bracket, UI retainer)	1054233
Screw, M4, captive, socket head, package of 10 (oxygen fitting retention plate)	1054232
Seal, solenoid valve, package of 4 (manifold)	1054236
Shielding clips, EMI shroud	1054247
Shroud, EMI (power supply)	1054248
Side panel, left	1054249
Side panel, right	1054250
Side wall, left (interior wall)	1054251
Side wall, right (interior wall)	1054252

Replacement Parts List

Table 9-1: V60 Ventilator Replacement Parts (Sheet 6 of 6)

Description	Part number
Solenoid valve (purge, autozero, crossover)	1054254
Solenoid valve, oxygen	1054253
Speaker assembly	1054255
Standoffs, M3 x 10, M-F, package of 5 (GDS manifold)	1054256
Standoffs, M3 x 30, M-F, package of 3 (flow sensor assembly, manifold)	1054267
Tape, Kapton, 3/4-in. wide (LCD cable, LCD tray)	1061127
Touch screen (front bezel)	1054268
Tray, CPU	1054269
Tray, LCD	1054270
Tubing kit, GDS (manifold to gas outlet port)	1054271
UI assembly, English	1054272
UI assembly, non-English	1054273
Washer, 9/64 ID x 5/8 OD, package of 10 (UI retainer)	1054289
Washer, lock, internal tooth, 1/2-in., package of 10 (nurse call jack)	1054319
Washer, M3 ID x 7 mm OD, package of 10 (LCD tray)	1054274
Washer, M3 ID x 9 mm OD, package of 10 (DA PCBA, speakers)	1054276
Washer, retainer, #6, plastic, package of 10 (capacitor bracket, oxygen fitting retainer, UI retainer)	1054288

9.2 Recommended Inventory Parts List

Table 9-2 lists the recommended replacement parts inventory for authorized Respironics V60 ventilator dealers and distributors.

Table 9-2: V60 Ventilator Recommended Inventory Parts (Sheet 1 of 3)

Description	Part number
Battery, internal	1056921
Battery, lithium	1056169
Blower assembly	1055434
Boot kit, rubber (GDS-blower and blower-output port boots)	1054197
Cable, backlight inverter PCBA	1054206
Cable, DA PCBA-flow sensors	1054218
Cable, DA PCBA-MC PCBA	1054217
Cable, gas outlet to ground	1054219
Cable, GDS GND	1054220
Cable, LCD	1054222
Cable, power harness	1054221
Cable, proximal port to ground	1054106
Cable, switch PCBA	1054223
Cable, UI GND	1054224
Cable, UI-PM PCBA	1054225
Clamp kit, hose (used to secure boots between GDS, blower, and outlet port)	1054239
Fan guard, filter, and retainer	1054246
Fan, cooling	1054277
Foot kit, bottom, package of 4	1054302
Filter, air inlet, package of 5	1054279
Filter, cooling fan, package of 5	1054280
Flow sensor assembly, air and oxygen	1058898
Gas delivery subsystem (GDS)	1054307
Gasket, air inlet collar. package of 5	1054308
Inlet, AC	1054318
LCD assembly	1054338
Mount, isolation, fan, package of 4	1055324
Nav-ring assembly (front bezel)	1054340
Nut, hex, kep, M4, package of 10 (base grounding lug)	1054341
Nut, hex, M12x1, stainless steel, package of 10 (nurse call jack)	1055321
Nut, wing, M3, package of 10 (MC PCBA to PCBA bracket)	1056418
O-ring, 2-023, Viton 70 DU, package of 5 (oxygen solenoid valve)	1054347

Replacement Parts List

Table 9-2: V60 Ventilator Recommended Inventory Parts (Sheet 2 of 3)

Description	Part number
O-ring, 2-121, Viton 50 DU, package of 5 (flow sensor assembly, oxygen filter)	1056662
O-ring, 2-103, Viton 70 DU, package of 5 (DA PCBA-manifold)	1054348
O-ring, 2-121, Viton 70 DU, package of 5 (flow sensor assembly, oxygen filter)	1054342
O-ring, 2-123, Viton 70 DU, package of 5 (air inlet)	1054343
O-ring, 2-135, Viton 70 DU, package of 5 (flow sensor assembly)	1054344
Overlay, power switch, English (UI)	1054350
Overlay, power switch, non-English (UI)	1054351
PCBA, backlight inverter	1054354
PCBA, CPU	1054355
PCBA, data acquisition (DA)	1054356
PCBA, motor controller (MC)	1054357
PCBA, power management (PM)	1054358
PCBA, switch (UI)	1054360
PCBA, user interface (UI)	1054361
Pin, locking, left side panel	1054362
Pin, locking, right side panel	1054363
Pin, push, fan mount, package of 4	1054235
Power cord, Argentina	1049627
Power cord, Australia	1049653
Power cord, China	1049628
Power cord, continental Europe	1043253
Power cord, Denmark	1049018
Power cord, Israel	1050940
Power cord, Italy	1049017
Power cord, North America	1043249
Power cord, South Africa	1043289
Power cord, Switzerland	1049016
Power cord, United Kingdom	1043287
Power supply	1054359
Screw, 2-32 x 3/8-in. L, self-tap, package of 10 (ferrite clip, capacitor bracket)	1054209
Screw, 6-32 x 1/4-in. L, pan head, package of 10 (power supply/EMI shroud)	1054210
Screw, M1.6 x 4, pan head, package of 10 (LCD to LCD tray)	1054212

Replacement Parts List

Table 9-2: V60 Ventilator Recommended Inventory Parts (Sheet 3 of 3)

Description	Part number
Screw, M2.5 x 6, socket head, package of 10 (oxygen solenoid valve clip)	1054214
Screw, M2.5 x 8, pan head, package of 10 (backlight inverter PCBA, AC inlet)	1054215
Screw, M3 x 12, pan head, package of 10 (MC PCBA)	1054229
Screw, M3 x 14, pan head, package of 10 (rear to front bezel, bezel end cap, flow sensor assembly)	1054230
Screw, M3 x 4, pan head, package of 10 (gas outlet port GND wire)	1054216
Screw, M3 x 6, pan head, package of 10 (CPU, CPU cover, speakers, base-CPU tray, power supply to mounting plate and base, PM PCBA, GDS GND wire, UI cable clamp, LCD tray GND wire, LCD-front bezel, switch PCBA, UI PCBA, UI GND wire)	1054227
Screw, M3 x 8, pan head, package of 10 (solenoid valve retention plate, oxygen solenoid valve mount, DA PCBA)	1054228
Screw, M4 x 14, socket head, package of 10 (bottom feet)	1054234
Screw, M4 x 5 dia. x 5 L, shoulder, package of 10 (blower mount)	1054211
Screw, M4 x 8, socket head, package of 10 (power cord retainer, capacitor bracket, battery bracket, top cover to base, base to front panel, base to side walls, air inlet filter frame, gas outlet bracket, UI retainer)	1054233
Solenoid valve (purge, autozero, crossover)	1054254
Solenoid valve, oxygen	1054253
Speaker assembly	1054255
Touch screen (front bezel)	1054268
Tubing kit, GDS (manifold to gas outlet port)	1054271
Washer, 9/64 ID x 5/8 OD, package of 10 (UI retainer)	1054289
Washer, lock, internal tooth, 1/2-in., package of 10 (nurse call jack)	1054319
Washer, M3 ID x 7 mm OD, package of 10 (LCD tray)	1054274
Washer, M3 ID x 9 mm OD, package of 10 (DA PCBA, speakers)	1054276
Washer, retainer, #6, plastic, package of 10 (capacitor bracket, oxygen fitting retainer, UI retainer)	1054288

9.3 Ventilator Chassis



Front bezel, English
P/N 1053892



Logo/product label kit
P/N 1054321



Power switch overlay, English
P/N 1054350



Rear bezel
P/N 1053896



UI retainer
P/N 1054208



Front panel assembly
P/N 1054306

Replacement Parts List



Left side panel
P/N 1054249



Right side panel
P/N 1054250



Air inlet filter housing
P/N 1054317



Air inlet filter retainer
P/N 1054105

9.4 Pneumatics

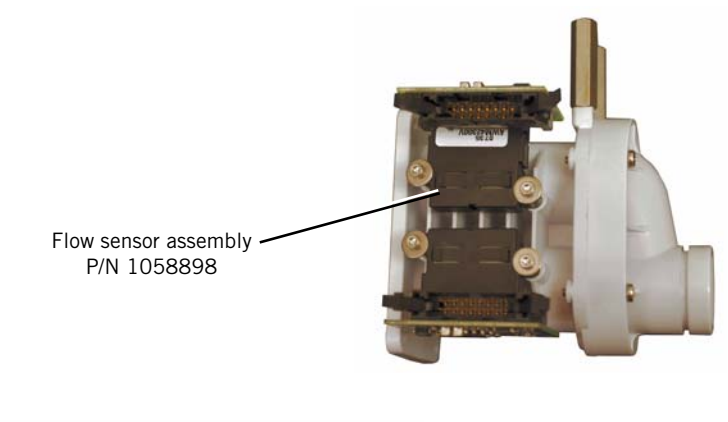
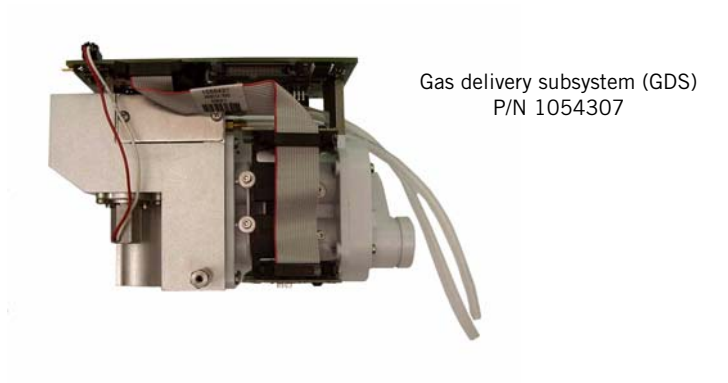

9.5 Electronics



Backlight inverter PCBA
P/N 1054354



CPU PCBA
P/N 1054355

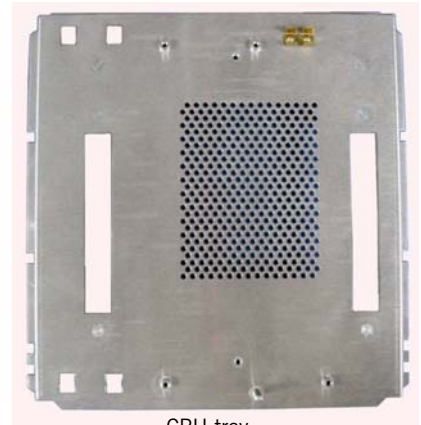

CPU tray
P/N 1054269

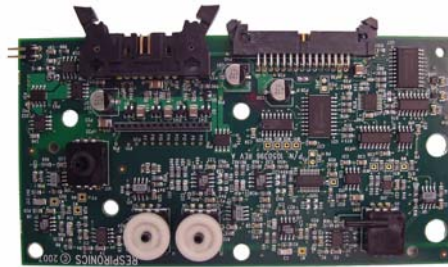

Data acquisition (DA) PCBA
P/N 1054356

Replacement Parts List



Motor controller (MC) PCBA
P/N 1054357



Power management (PM) PCBA
P/N 1054358



Switch PCBA
P/N 1054360



User interface (UI) PCBA
P/N 1054361

Replacement Parts List

A

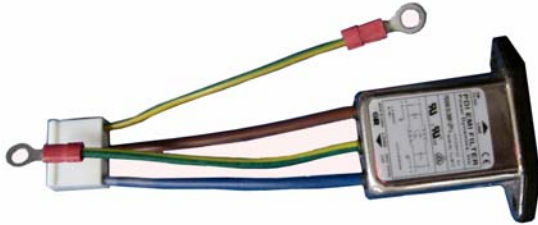

AC inlet
P/N 1054318



LCD tray
P/N 1054270



Power supply
P/N 1054359

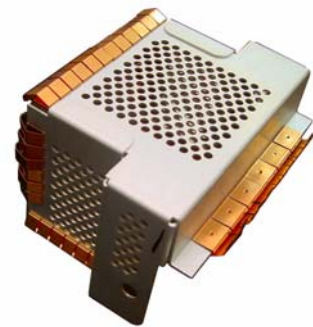

EMI shroud
P/N 1054248



Speaker assembly
P/N 1054255

Replacement Parts List

(This page is intentionally blank.)

Chapter 10. Specifications

10.1 Control settings

Table 10-1 lists ventilator control setting ranges, resolutions, and accuracies. Table 10-2 lists the controls active in the different ventilation modes.

Table 10-1: Control setting ranges, resolutions, and accuracies

Parameter	Range	Resolution	Accuracy	Factory default
Mode settings				
Modes	CPAP, S/T, PCV, AVAPS (optional)	N/A	N/A	S/T
Control settings				
C-Flex	OFF, 1 to 3	1	N/A	2
CPAP	4 to 25 cmH ₂ O	1 cmH ₂ O	± (2 cmH ₂ O + 4% of target)	4 cmH ₂ O
EPAP	4 to 25 cmH ₂ O	1 cmH ₂ O	± (2 cmH ₂ O + 4% of target)	4 cmH ₂ O
IPAP	4 to 40 cmH ₂ O	1 cmH ₂ O	± (2 cmH ₂ O + 4% of target)	12 cmH ₂ O
I-Time (Inspiratory Time)	0.30 to 3.00 sec	0.05 sec	± 0.03 sec	1.00 sec
Max P (AVAPS Maximum IPAP Pressure)	6 to 40 cmH ₂ O	1 cmH ₂ O	± (2 cmH ₂ O + 4% of target)	25 cmH ₂ O
Min P (AVAPS Minimum IPAP Pressure)	5 to 30 cmH ₂ O	1 cmH ₂ O	± (2 cmH ₂ O + 4% of target)	10 cmH ₂ O
O ₂ (Oxygen)	21 to 100%	1%	± 5%	21%
Ramp Time	OFF, 5 to 45 min	5 min	± 1 sec	OFF
Rate (Respiratory Rate)	4 to 60 BPM	1 BPM	± 1 BPM	4 BPM
Rise (Rise Time)	1 to 5	1	N/A	3
V _T (AVAPS Target Tidal Volume)	200 to 2000 mL BTPS	5 mL	± 15%	500 mL

Chapter 10
Specifications

Table 10-2: Controls active in Respironics V60 ventilation modes

	CPAP	S/T	PCV	AVAPS
Timing		Rate		
		I-Time		
Baseline pressure	CPAP	EPAP		
Inspiratory pressure		IPAP		
				MinP
				MaxP
Rise Time		Rise		
O ₂	O ₂			
Volume				V _T
Ramp feature	Ramp Time			
Mode-specific	C-Flex			

10.2 Patient data

Table 10-3: Patient data ranges, resolutions, and accuracies

Parameter	Range	Resolution	Accuracy
Patient data window			
<i>Breath phase/trigger indicator</i>	Spont, Timed, Exhale	Color-coded display: Spont - turquoise, Timed - orange, Exhale - blue	N/A
PIP	0 to 50 cmH ₂ O	1 cmH ₂ O	± 2 cmH ₂ O
Pt. Leak	0 to 200 L/min BTPS	1 L/min	N/A
Pt. Trig	0 to 100%	1%	± 10%
Rate	0 to 90 BPM	1 BPM	± 1 BPM
T _I /T _{TOT}	0% to 91%	1%	± 5%
Tot. Leak	0 to 200 L/min BTPS	1 L/min	N/A
V _E	0 to 99.0 L/min BTPS	0.1 L/min	± 15% or 0.3 L/min (whichever is greater)
V _T	0 to 3000 mL BTPS	5 mL	± 15% for volumes above 200 mL
Waveform window			
<i>P waveform</i>	0 to 50 cmH ₂ O	Time axis: 1 second	N/A
<i>V_E waveform</i>	-240 to 240 L/min BTPS	Time axis: 1 second	N/A
<i>V waveform</i>	0 to 3000 mL BTPS	Time axis: 1 second	N/A

10.3 Alarms

Table 10-4 lists the adjustable alarm ranges and resolutions.

Table 10-4: Adjustable alarm ranges and resolutions

Parameter	Range	Resolution	Factory default
Hi Rate (High Rate Alarm)	5 to 90 BPM	1 BPM	30 BPM
Lo Rate (Low Rate Alarm)	1 to 89 BPM	1 BPM	10 BPM
Hi V_T (High Tidal Volume Alarm)	200 to 2500 mL BTPS	5 mL	2500 mL
Lo V_T (Low Tidal Volume Alarm)	OFF, 5 to 1500 mL BTPS	5 mL	OFF
HIP (High Inspiratory Pressure Alarm)	5 to 50 cmH ₂ O	1 cmH ₂ O	50 cmH ₂ O
LIP (Low Inspiratory Pressure Alarm)	OFF, 1 to 40 cmH ₂ O	1 cmH ₂ O	OFF
Lo \dot{V}_E (Low Minute Ventilation Alarm)	OFF, 1 to 99 L/min BTPS	1 L/min	OFF
LIP T (Low Inspiratory Pressure Delay Time Alarm)	5 to 60 sec	1 sec	20 sec

10.4 Menu window settings

Table 10-5: Menu window settings and ranges

Parameter	Range
Brightness	1 to 5
Loudness	1 to 10
Mask/ET Selection	ET/Trach, 1, 2, 3, 4, Other
Exhalation Port Selection	DEP (Respironics Disposable Exhalation Port), Whisper Swivel (Respironics Whisper Swivel), PEV (Respironics Plateau Exhalation Valve, Other (Other Exhalation Port), None (No inline circuit exhalation port)
Screen Lock	Off, On

10.5 Operator-accessible diagnostic mode functions

Table 10-6: Diagnostic mode functions

Function	Range
Language	English, Nederlands, Français, Deutsch, Italiano, Português, Español
Date/Time	--
Pressure Units	cmH ₂ O, hPa
Restore Default Settings	--
Software Options	--
Baud Rate	9,600, 19,200, 115,200
Significant Event Log	--
Touch Screen Calibration	--

10.6 Physical characteristics

Table 10-7: Physical characteristics

Parameter	Specification
Weight	10.9 kg (24 lb) with optional battery 10 kg (22 lb) without battery
Dimensions	<p>(33.7 cm) 13.3 in.</p> <p>(39.4 cm) 15.5 in.</p> <p>(42.9 cm) 16.5 in.</p>

10.7 Environmental specifications

Table 10-8: Environmental specifications

Parameter	Specification
Temperature	Operating: 5 to 40 °C (41 to 104 °F) Storage: -20 to 50 °C (-4 to 122 °F)
Relative humidity	Operating: 15 to 95% (noncondensing) Storage: 10 to 95% (noncondensing)
Barometric pressure	600 to 765 mmHg (approximately -51 to 1951 m/ -200 to 6400 ft relative to sea level)



10.8 Pneumatic specifications

Table 10-9: Pneumatic specifications

Parameter	Specification
High-pressure oxygen supply	Pressure: 2.76 to 6.00 bar / 276 to 600 kPa / 40 to 87 psig Flow: 175 SLPM Connector: DISS male, DISS female, NIST, SIS
Air supply	Integrated blower
Inspiratory outlet (To patient port)	Connector: ISO 15 mm female/22 mm male conical

10.9 Electrical specifications

Table 10-10: Electrical specifications

Parameter	Specification
AC voltage	100 to 240 VAC
AC frequency	50 to 60 Hz
AC power	300 VA
Battery (optional)	14.4 V, 11.5 Ah Maximum system current draw: 11 A Charge voltage: +16.9 V maximum Operating time: 360 minutes under normal conditions
Power source indicators	 <p><i>Powered by AC with Battery Present icon:</i> Ventilator powered by AC power, internal battery is installed</p>
	 <p><i>Powered by AC without Battery icon:</i> Ventilator powered by AC power, internal battery is not installed</p>
	 <p><i>Battery Capacity Indicator icon:</i> Ventilator powered by internal battery.</p>

10.10 Other specifications

Table 10-11: Other specifications

Parameter	Specification
Flow delivery	150 L/min at 40 cmH ₂ O at 1951 m (6400 ft) altitude (10% degradation in flow at 2286 m/7500 ft)
Demand flow range	-240 to 240 L/min BTPS
Pressure range	4 to 40 cmH ₂ O
Dynamic pressure regulation	± (2 cmH ₂ O + 4% of target) NOTE: Negative (subatmospheric) pressure settings are not available.
Start-up time	Ready to ventilate 9 seconds after power on
Triggering, cycling, and leak tolerance	As per the Digital Auto-Trak Sensitivity algorithms (see <i>V60 Ventilator Operator's Manual</i>)
Inspiratory and expiratory pressure drop: measured at patient connection, when the recommended breathing system is in use and normal ventilation is compromised by the total or partial loss of power supply	≤ 40 cmH ₂ O (at 60 LPM) ≤ 1.5 cmH ₂ O (at 30 LPM)
Audio alarm loudness	60 to 95 dBA (primary alarm) ≥ 65 dBA (backup alarm)
Acoustic noise	Less than 45 dB (A) at 1 m)

10.11 Contact Information

For further information or technical assistance, contact Respironics Customer Service:

- By email: service@respironics.com
- In the U.S.: **800-345-6443**
- Outside the U.S.: **724-387-4000** (phone) or **724-387-5012** (fax)

Appendix A Respi-Link

This section describes the following Respi-Link functions:

- Downloading V60 ventilator software
- Installing a V60 ventilator option
- Remote troubleshooting

A.1 Downloading Ventilator Software

Follow these steps to download V60 ventilator software using Respi-Link.

NOTE: Do not connect the null modem cable until instructed to do so.

1. Turn on the PC and verify that the Gateway interface is running by double-clicking on **Start Auto Respi-Link Gateway** in the Respi-Link folder on your desktop.
2. If the ventilator is not already in Diagnostic mode, press and hold the nav-ring **Enter** button and turn on the ventilator by pressing the **On/Shutdown** button on the user interface. Within 5 seconds, release and press the nav-ring **Enter** button again to enter Diagnostic mode.
3. Connect a standard 9-pin male-female RS-232 null modem cable and 9-pin to 25-pin female-male adapter between the PC serial port and the V60 ventilator.
4. Within 30 seconds, the GatewayInterface screen appears on the PC monitor if a software package is pending (Figure A-1).

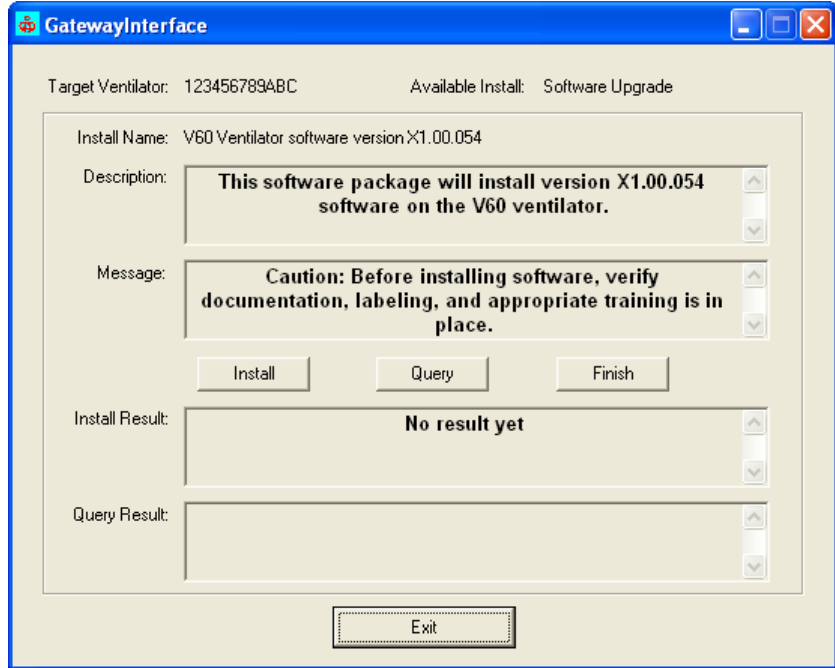

Figure A-1: Software Package Screen

5. Verify that the serial number on the GatewayInterface screen matches the serial number on the V60 ventilator.
6. Click **Install** to continue, **Finish** to discard the package or **Exit** to install the package at a later date.
7. When the confirmation screen appears, click **Yes** to continue the software installation or **No** to exit (Figure A-2).

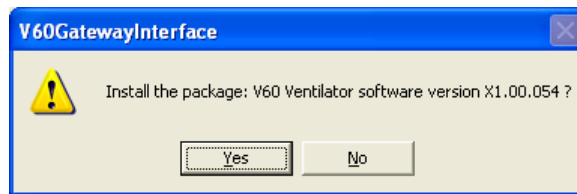

Figure A-2: Confirmation Screen

8. When the V60 installation program screen appears, place the V60 ventilator in software download mode by touching **Service, Misc**, then **Download mode**.

9. When the V60 ventilator is in download mode, click **Next** to continue or **Cancel** to exit (Figure A-3).

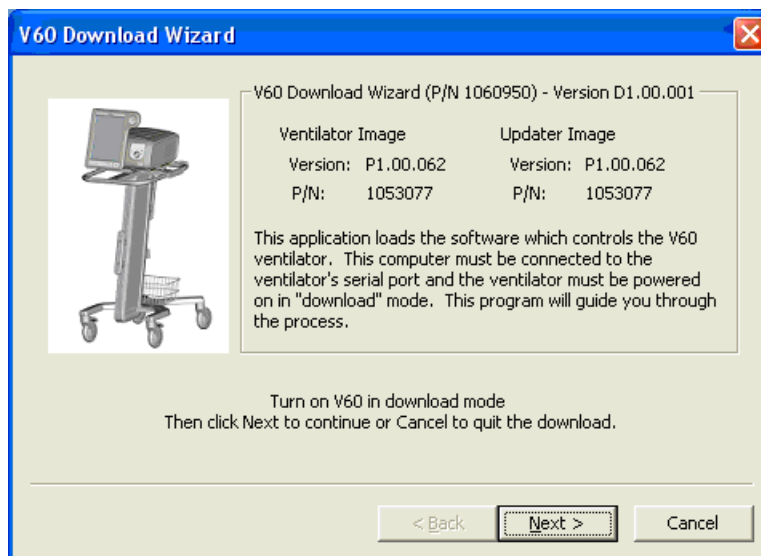

Figure A-3: V60 Installation Program

10. Select the serial port that the V60 is connected to (Figure A-4).

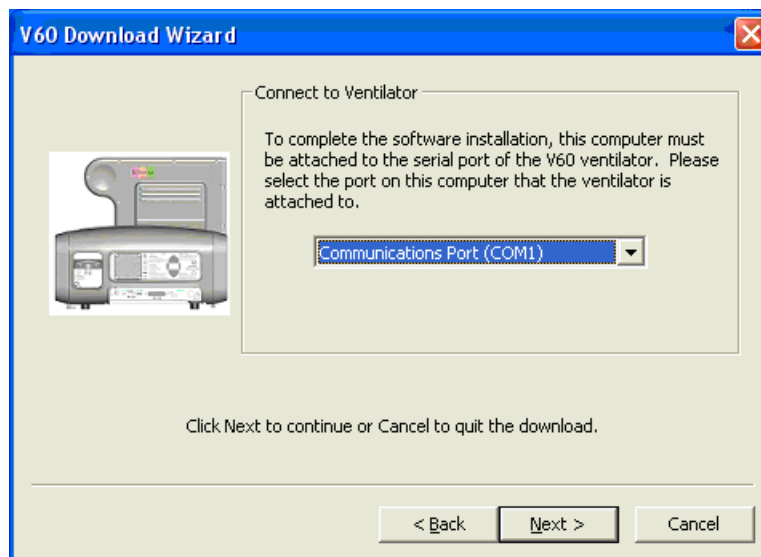

Figure A-4: Serial Port Connection

11. Click **Next** to start the download sequence or **Cancel** to exit.

12. The updater image download starts and a progress bar is displayed (Figure A-5).

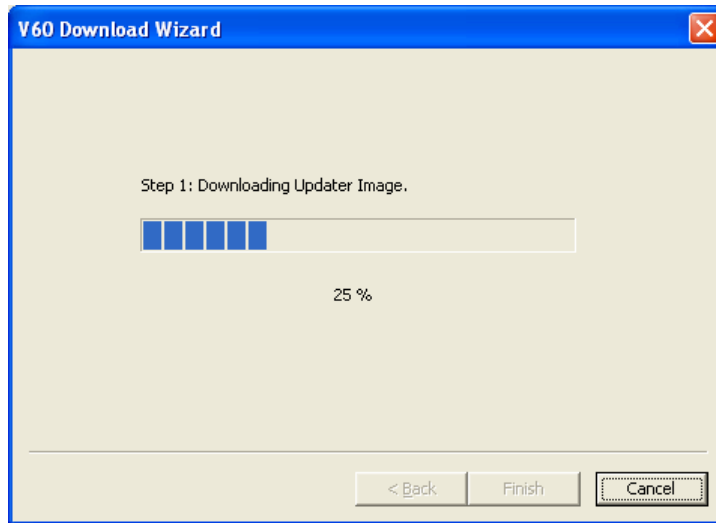

Figure A-5: Updater Image Download

13. When the updater image download is complete the ventilator image download starts automatically (Figure A-6).

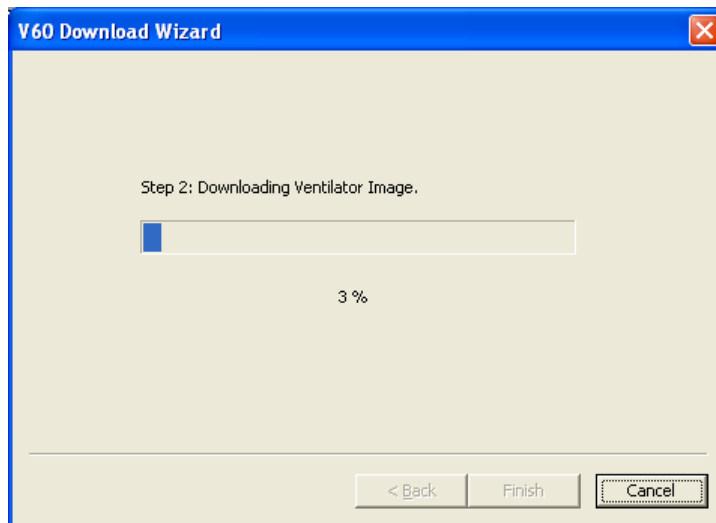

Figure A-6: Ventilator Image Download

14. When the download is complete, click **Finish** (Figure A-7).

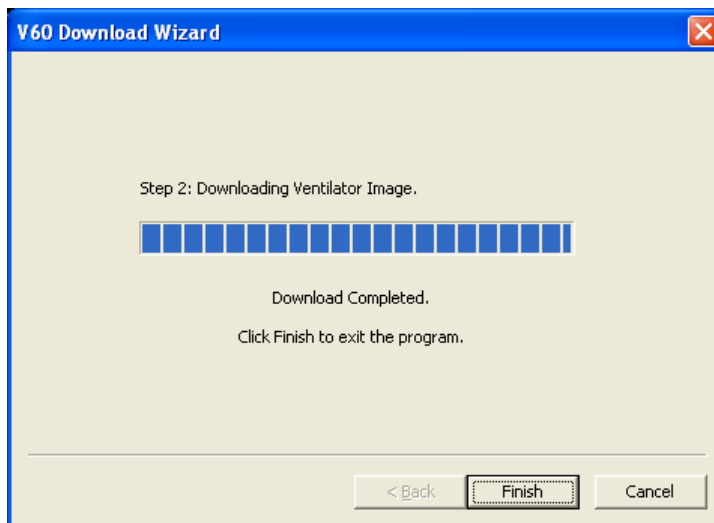

Figure A-7: Download Completed

15. When the V60 installation program screen closes, click **Finish** on the GatewayInterface screen to send confirmation to Respi-Link that the software installation was successful (Figure A-8).

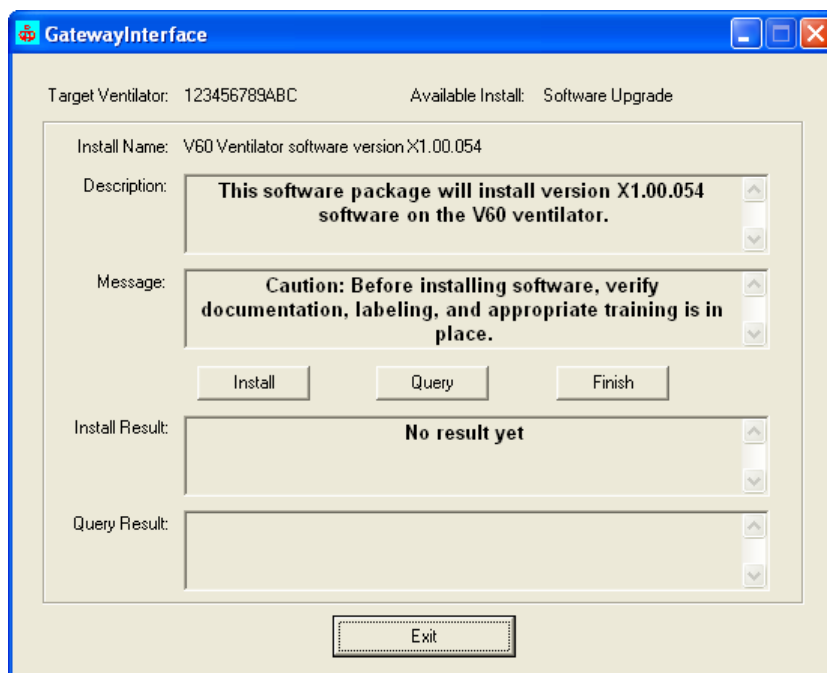

Figure A-8: Installation Confirmation Screen

16. Remove the null modem cable and adapter from the V60 ventilator.
17. Turn the V60 ventilator off by pressing and holding the **On/Shutdown** button on the user interface.
18. Enter Diagnostic mode by pressing and holding the nav-ring **Enter** button and turn on the ventilator by pressing the **On/Shutdown** button on the user interface. Within 5 seconds, press the nav-ring **Enter** button again to enter Diagnostic mode.
19. Touch **Service** and verify that the Software Version is the same as the version listed on the GatewayInterface screen (Figure A-8).
20. Click **Exit** on the GatewayInterface screen.
21. Turn the V60 ventilator off by pressing the **On/Shutdown** button, then touch **Ventilator Shutdown**.
22. Software download is complete.

A.2 Installing Ventilator Options

Follow these steps to install V60 ventilator options using Respi-Link.

NOTE: Do not connect the null modem cable until instructed to do so.

1. Turn on the PC and verify the Gateway Interface is running by double-clicking on **Start Auto Respi-Link Gateway** in the Respi-Link folder on your desktop.
2. If the ventilator is not already in Diagnostic mode, press and hold the nav-ring **Enter** button and turn on the ventilator by pressing the **On/Shutdown** button on the user interface. Within 5 seconds, release and press the nav-ring **Enter** button again to enter Diagnostic mode.
3. Connect a standard 9-pin male-female RS-232 null modem cable and 9-pin to 25-pin female-male adapter between the PC serial port and the V60 ventilator.

4. Within 30 seconds, a GatewayInterface screen appears on the PC monitor if an option package is pending (Figure A-9).

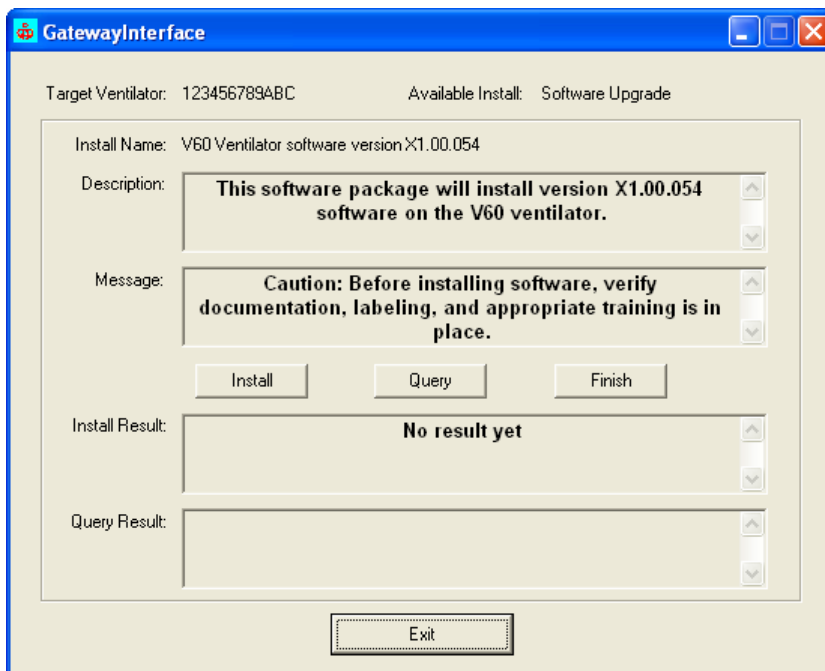

Figure A-9: Option Package Screen

5. Verify that the serial number on the GatewayInterface screen matches the serial number on the V60 ventilator.
6. Click **Install** to continue, **Finish** to discard the package, or **Exit** to install the package at a later date.
7. At the confirmation screen, click **Yes** to continue the option installation or **No** to exit (Figure A-10).

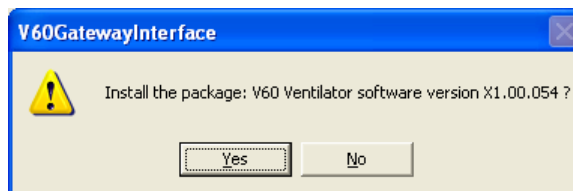

Figure A-10: Confirmation Screen

8. Click **Finish** on the GatewayInterface screen to send confirmation to Respi-Link that the option installation was successful.

9. Touch **Service** and verify the Options on the V60 ventilator are the same as the options listed on the GatewayInterface screen.
10. Click **Exit** on the GatewayInterface screen.
11. Turn the V60 ventilator off by pressing the **On/Shutdown** button.
12. Option installation is complete.

A.3 Reinitiate a Software Package

Follow these steps to reinitiate a V60 ventilator software package using Respi-Link.

NOTE: Do not connect the null modem cable until instructed to do so.

1. Turn on the PC and verify the Gateway Interface is running by double-clicking on **Start Auto Respi-Link Gateway** in the Respi-Link folder on your desktop.
2. If the ventilator is not already in Diagnostic mode, press and hold the nav-ring **Enter** button and turn on the ventilator by pressing the **On/Shutdown** button on the user interface. Within 5 seconds, release and press the nav-ring **Enter** button again to enter Diagnostic mode.
3. Connect a standard 9-pin male-female RS-232 null modem cable and 9-pin to 25-pin female-male adapter between the PC serial port and the V60 ventilator.
4. Double click on the GatewayInterface icon to re-launch the install screen (Figure A-11).



Figure A-11: GatewayInterface icon

5. A GatewayInterface screen appears on the PC monitor if a software package was previously suspended (Figure A-12).

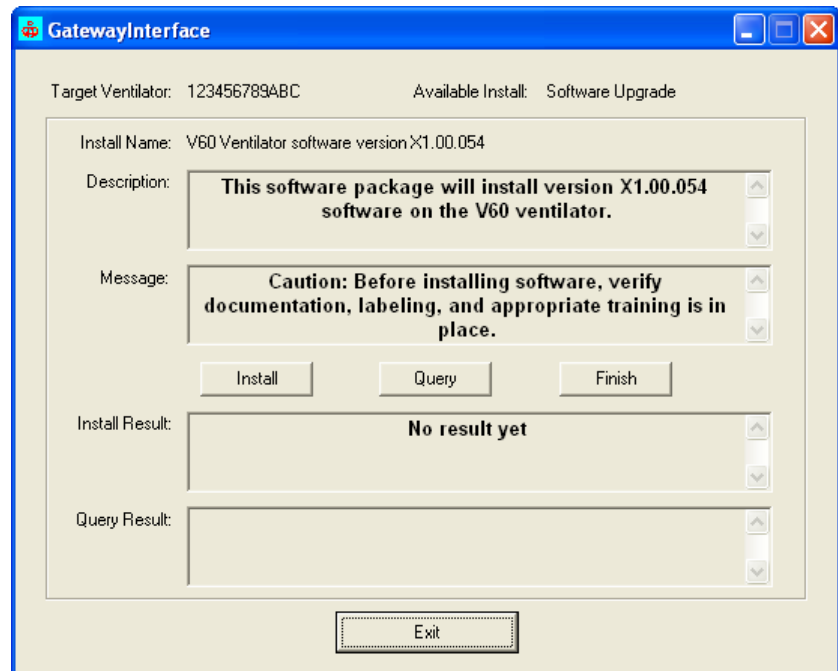

Figure A-12: Software Package Screen

6. Verify that the serial number on the GatewayInterface screen matches the serial number on the V60 ventilator.
7. Click **Install** to continue, **Finish** to discard the package, or **Exit** to install the package at a later date.
8. At the confirmation screen, click **Yes** to continue the software installation or **No** to exit (Figure A-13).

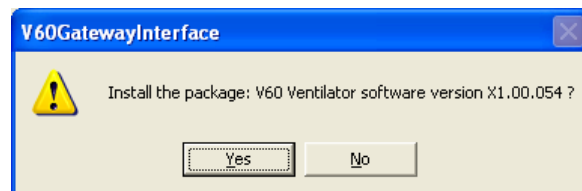

Figure A-13: Confirmation Screen

9. When the V60 installation program screen appears place the V60 ventilator in software download mode by touching **Service, Misc**, then **Download mode**.

10. When the V60 ventilator is in download mode, click **Next** to continue or **Cancel** to exit (Figure A-14).

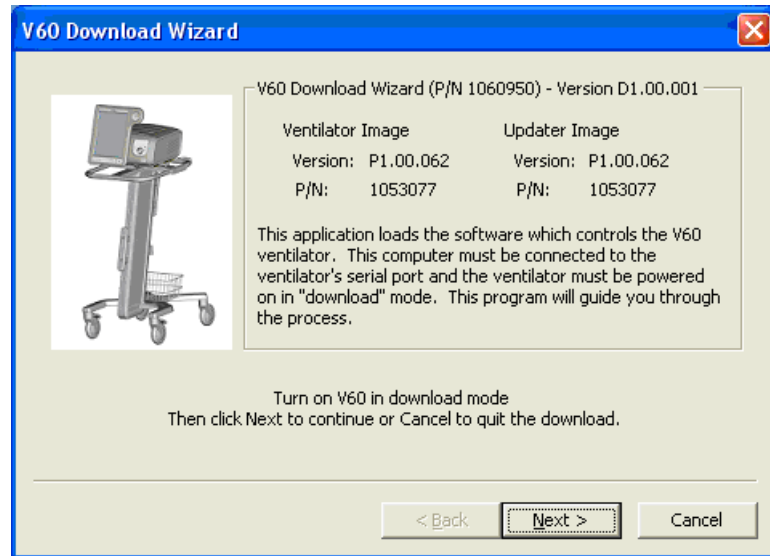

Figure A-14: V60 Installation Program

11. Select the serial port that the V60 is connected to (Figure A-15).

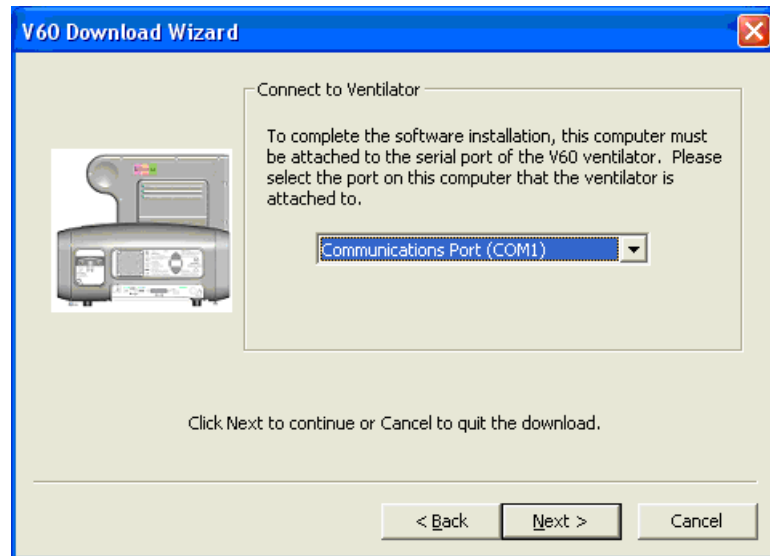

Figure A-15: Serial Port Connection

12. Click **Next** to start the download sequence or **Cancel** to exit.

13. The updater image download starts and a progress bar is displayed (Figure A-16).

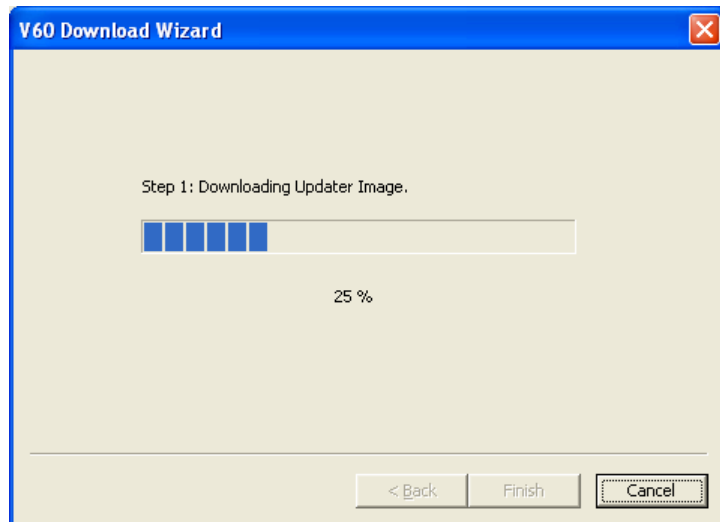

Figure A-16: Updater Image Download

14. When the updater image download is complete the ventilator image download starts automatically (Figure A-17).

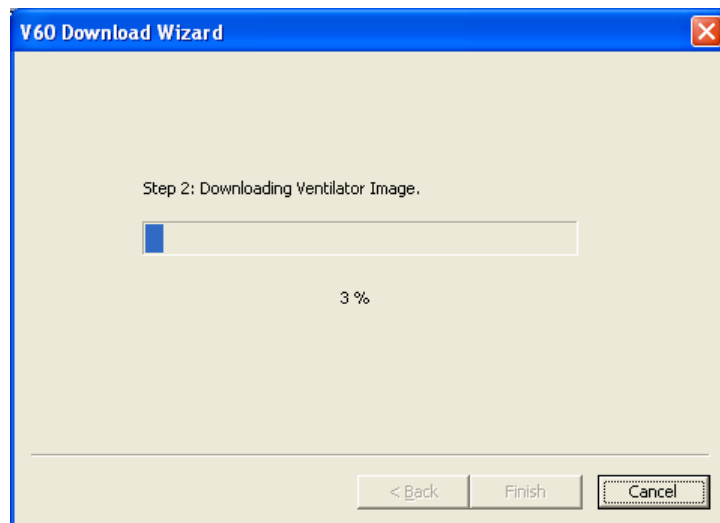

Figure A-17: Ventilator Image Download

15. When download is complete, click **Finish** (Figure A-18).

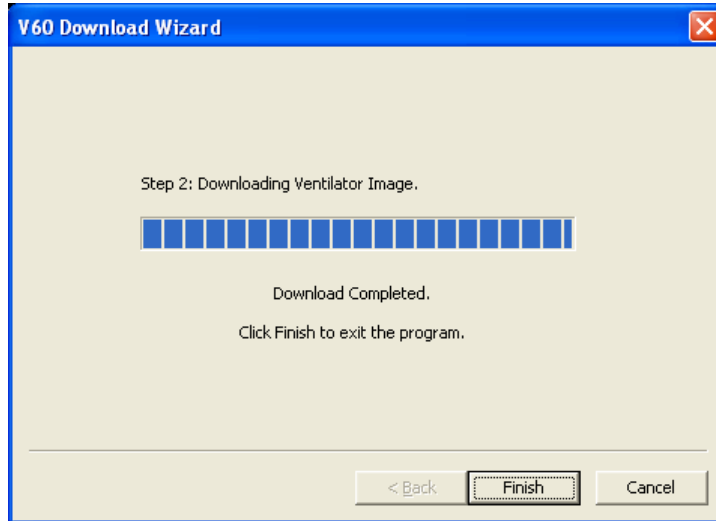

Figure A-18: Download Completed

16. When the V60 installation program screen closes, click **Finish** on the GatewayInterface screen to send confirmation to Respi-Link that the software installation was successful (Figure A-19).

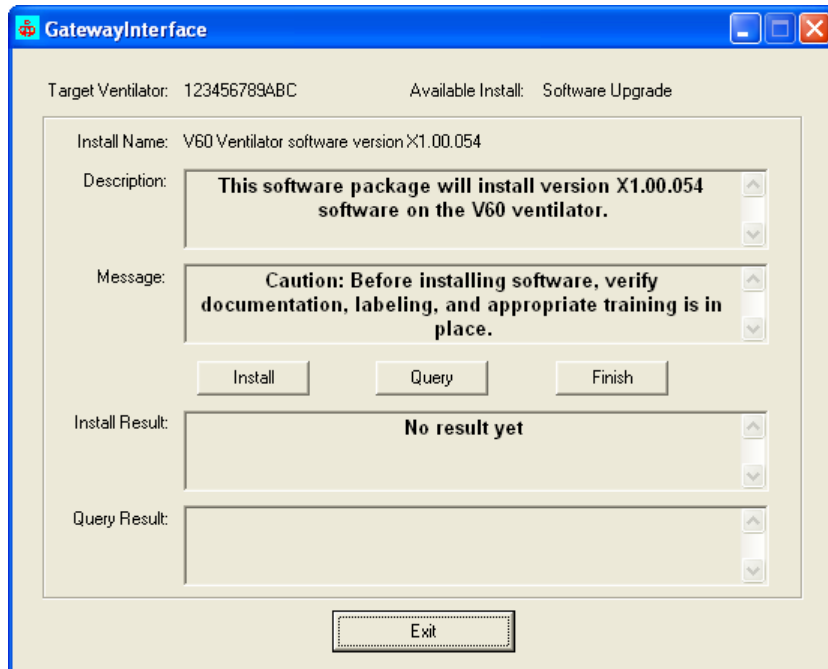

Figure A-19: Installation Confirmation Screen

17. Remove the null modem cable and adapter from the V60 ventilator.
18. Turn the V60 ventilator off by pressing and holding the **On/Shutdown** button on the user interface.
19. Enter Diagnostic mode by pressing and holding the nav-ring **Enter** button and turn on the ventilator by pressing the **On/Shutdown** button on the user interface. Within 5 seconds, release and press the nav-ring **Enter** button again to enter Diagnostic mode.
20. Touch **Service** and verify the Options on the V60 ventilator are the same as the options listed on the GatewayInterface screen.
21. Click **Exit** on the GatewayInterface screen.
22. Turn the V60 ventilator off by pressing the **On/Shutdown** button.
23. Software reinitiation is complete.

A.4 Remote Troubleshooting

Follow these steps to connect the V60 ventilator to Respi-Link and prepare for remote troubleshooting.

NOTE: Do not connect the null modem cable until instructed to do so.

1. Turn on the PC and verify the Gateway Interface is running by double-clicking on **Start Auto Respi-Link Gateway** in the Respi-Link folder on your desktop.
2. If the ventilator is not already in Diagnostic mode, press and hold the nav-ring **Enter** button and turn on the ventilator by pressing the **On/Shutdown** button on the user interface. Within 5 seconds, press the nav-ring **Enter** button again to enter Diagnostic mode.
3. Touch **Service**, then **Pneumatics**.
4. Connect a standard 9-pin male-female RS-232 null modem cable and 9-pin to 25-pin female-male adapter between the PC serial port and the V60 ventilator.
5. The V60 ventilator is now connected to Respi-Link and can be monitored remotely by a Respirationics representative.
6. Contact your local service representative or Product Support at 800-345-6443 for further instructions.

(This page is intentionally blank.)

Appendix B Field Communications

Save field communications in this section.

(This page is intentionally blank.)

A

- AC inlet
 - part number 9-15
- AC power
 - specifications 10-7
- Accessories
 - Recommended for servicing 1-3
- Acoustic noise specifications 10-8
- Air flow accuracy
 - performance verification test 8-24
- Alarm speakers
 - removal/installation 7-15
- Alarms 10-4
 - adjustable, specifications 10-4

B

- Baclight inverter PCBA
 - part number 9-13
- Battery, backup
 - specifications 10-7
- Blower assembly
 - part number 9-12
- Brightness, display
 - specifications 10-4

C

- Communication between service PC and ventilator 6-1
- Control settings
 - ranges, resolutions, and accuracies 10-1
- CPU PCBA
 - part number 9-13
- CPU tray
 - part number 9-13

D

- Data acquisition (DA) PCBA
 - part number 9-13
- Delivered pressure specifications 10-8
- Demand flow specifications 10-8
- Diagnostic report (DRPTA), generating 6-17
- Dimensions, ventilator 10-5
- Downloading ventilator software 6-21

E

- Electrical safety
 - test 8-15
 - troubleshooting 8-38
- Electrical specifications 10-7
- Electronics
 - Signal path sequence 3-14
- EMI shroud
 - part number 9-15
- Environmental specifications 10-6

F

- Filter retainer, air inlet
 - part number 9-11
- Flow sensor assembly
 - part number 9-12
- Front bezel
 - part number 9-10

G

- Gas delivery subsystem (GDS)
 - leak test requirements 7-1
 - part number 9-12
 - schematic 3-2
- Gas outlet port
 - part number 9-12

H

- Housing, air inlet filter
 - part number 9-11

L

- Label kit, logo/product
 - part number 9-10
- LCD tray
 - part number 9-15
- Left side panel
 - part number 9-11
- Left side wall
 - removal/installation 7-20

M

- Mains power
 - specifications 10-7
- Maintenance schedule 4-1
- Monitored parameters
 - ranges, resolutions, and accuracies 10-3
- Motor controller (MC) PCBA
 - part number 9-14

O

- Oxygen flow accuracy
 - performance verification test 8-27

P

- Parts list, complete 9-1
- Parts list, recommended inventory parts 9-7
- Patient data
 - ranges, resolutions, and accuracies 10-3
- Pneumatic specifications 10-6
- Power management (PM) PCBA
 - part number 9-14
- Power supply
 - part number 9-15

Index

Power switch overlay
part number 9-10
Power-on hours, reprogramming 6-21
Pressure accuracy
performance verification test 8-21

R

Rear bezel
part number 9-10
Recommended inventory parts list 9-7
Reports and software downloads, description 6-1
Returning ventilator to operation
See Ventilator operation
Right side panel
part number 9-11
Right side wall
removal/installation 7-23

S

Serial number, reprogramming 6-21
Side panels
part numbers 9-11
Signal paths
See Electronics
Significant event log, clearing 6-20
Speaker assembly
part number 9-15
Specifications 10-1
acoustic noise 10-8
alarm settings 10-4
control settings 10-1
delivered pressure 10-8
demand flow 10-8
dimensions 10-5
display brightness 10-4
electrical 10-7
environmental 10-6
monitored parameters 10-3
patient data 10-3
pneumatic 10-6
ventilator start-up time 10-8
weight 10-5
Start-up time specifications 10-8
Switch PCBA
part number 9-14

T

Test equipment
Recommended for servicing 1-3
Tools
Recommended for servicing 1-3
Top cover
removal/installation 7-5

U

UI retainer
part number 9-10
User interface (UI) PCBA
part number 9-14

V

Ventilator operation
returning to operation 8-37
Ventilator software, downloading 6-21

W

Warnings and Cautions 2-1
Weight, ventilator 10-5

Other ManualsLib Projects



www.manualslib.com



www.manualslib.de



www.manualslib.es



www.manualslib.fr



www.manualslib.nl



www.manualslib.mx



www.manualslib.tech 30+ Languages